

This Brochure is prepared by Daimler AG and it predominantly reflects the capabilities and performance of vehicles sold in Europe. Some characteristics, capabilities, performance features and optional extras (e.g. towing systems) may not be available or may not apply in Australia or under Australian conditions. The information in this Brochure is therefore indicative, illustrative and provided only for guidance and should not be relied on. To obtain current and accurate information on a vehicle and any options applicable to Australia, contact your local authorised Mercedes-Benz dealer.



Mercedes-Benz

# The SL-Class



Mercedes-Benz

From the Mercedes-Benz dream factory

# Contents

<b>The SL</b>	<b>6</b>	<b>My SL</b>	<b>64</b>
<b>Agility</b>	<b>14</b>	<b>Equipment &amp; appointments</b>	<b>66</b>
BlueEFFICIENCY	14	Sports package	66
Engines	16	Standard equipment	70
Transmissions	26	Light-alloy wheels	72
Chassis & suspension	28	Seats	76
Direct-Steer system	30	Optional extras	78
AIRSCARF	32	Genuine accessories	80
		designo	82
<b>Comfort</b>	<b>34</b>		
Vario-roof	34	<b>Services</b>	<b>88</b>
Interior	36		
Seating comfort	40	<b>Colours and materials</b>	<b>92</b>
SL 600	42	Combination options	92
COMAND APS	44	Trim, wood and designo	93
Surround sound system	46	Upholstery and leather	94
		Paintwork	97
<b>Safety</b>	<b>48</b>		
		<b>Technical data</b>	<b>95</b>
<b>AMG</b>	<b>54</b>		

# About as close to heaven on earth as it gets

How do you continue what is already a staggering success story? Simple. By making things even better. This is also very much the philosophy behind the SL. With more powerful, more economical engines. With design elements such as side gills painted in either silver (SL 600) or the vehicle colour (all other models). With a sporty front section and rear end. Plus a choice of exclusive paint finishes and, to round it all off, a selection of attractive wheels. One thing is apparent right away: the latest generation first celebrates and then builds upon the great achievements of the past.

## Two letters are enough to write a legend: SL



It takes three days to cover the 1000 miles from Brescia in Lombardy to Rome and back, on roads which run through sleepy villages and across impressive piazzas. This is, of course, the route of the world's most famous road race of all. We're taking the SL back to the route on which its distinguished ancestor, another series-production roadster, made history back in 1955. Raced by the Fitch/Gesell Team, the 300 SL of more than half a century ago left all the favoured Italian models in the GT class above 1.6 litres



trailing in its wake. And now we're revisiting this culturally rich route in a roadster which sets new standards for refined driving and whose engine and chassis provide ample evidence that they are worthy of the legendary SL name. The design, appointments and sound of the roadster are as impressive to outside observers as they are to the driver. Now you can write the next chapter of the 300 SL Gullwing legend yourself. Such rare pieces of Mercedes-Benz history can still be acquired by visiting [www.mercedes-benz.de/classic](http://www.mercedes-benz.de/classic)









The SL





A sports car has to get under your skin to find its way to your heart



When you're leading the way, it's nice to know you look good from behind



SL 600



S SL 6001





Adrenaline - the only fuel you take on board whilst on the move



## BlueEFFICIENCY – fast forward to tomorrow

We are quicker at getting environmentally friendly future technologies to where it matters most: on the road. As the inventor of the motor car, Mercedes-Benz has a special responsibility – one we have undertaken with all our might for many years. By the end of 2011, we will be able to offer you 128 models with BlueEFFICIENCY technologies, all of which help you reduce your impact on the environment – without compromising on safety, comfort and driving enjoyment.

Our BlueEFFICIENCY concept comprises innovations for efficient mobility as well as optimised processes all the way along the value chain. They involve different approaches, but they all have a common goal: to make your individual mobility as sustainable as possible.

**The BlueEFFICIENCY measures – the Mercedes-Benz efficiency package.** This package consists of comprehensive vehicle optimisations designed to save fuel and ease the burden on the environment. Each model combines the

most efficient engine with latest-generation aerodynamic and energy-management measures to minimise fuel consumption. Such measures include intelligently controlled ancillaries, tyres with optimised rolling resistance, lightweight components and the ECO start/stop function, which is being made available for an increasing number of models. The new BlueDIRECT V6 and V8 petrol engines, which feature in several model series, deliver a much higher power output while reducing fuel consumption by up to 24%.

**BlueTEC – the clean diesel.** Mercedes-Benz has brought to market BlueTEC technology for diesel engines based on common-rail direct injection (CDI). A modular emission-control system makes BlueTEC an exceptionally clean diesel technology, as not only does it remove up to 95% of the particulate matter from the exhaust gases, it also reduces nitrogen oxides by up to 90%. What remains is mainly water, nitrogen and the satisfying feeling of having helped to ease the burden on the environment.

**HYBRID – petrol and electric drives intelligently combined.** A well-established team makes a lot of things easier. As shown by HYBRID technology. Here the electric motor is used for the recuperation of kinetic energy. This energy is stored in the battery and returned to the electric drive when needed, which assists the petrol engine when the car is accelerating. What's more, the ECU shuts off the petrol engine when the speed is below 15 km/h. In this way, a HYBRID can reduce fuel consumption by up to 20%. So it looks after the environment as well as your bank balance. Perfect teamwork, you might say.



The BlueEFFICIENCY measures bring about a substantial reduction in fuel consumption and CO<sub>2</sub> emissions





**BlueTEC HYBRID – clean diesel combined with electric drive.** It marries the benefits of the HYBRID with those of BlueTEC: during braking, the kinetic energy is converted into electrical energy, which can be re-used when required. At the same time, the BlueTEC technology cleans exhaust gases and removes many of the pollutants. All of which makes the economical diesel powerplant even more efficient, agile and clean.



We are using **BlueTEC HYBRID technology** to develop a diesel hybrid based on the E-Class

**Innovative drive systems that break new ground: E-CELL and F-CELL.** Mercedes-Benz has developed two locally emission-free drive systems known as the E-CELL and F-CELL. The B-Class F-CELL is already being produced on a small scale and has been displaying its everyday practicality on Germany's roads since mid-2010. It uses hydrogen to produce power for the electric motor in a fuel cell. The first vehicles from a small series of the A-Class E-CELL – which features an electric motor that draws its energy from two lithium-ion batteries, giving it an average range of more than 200 km – began rolling



The A-Class **E-CELL** allows locally emission-free driving with a battery-powered electric motor

off the production line at the end of 2010. An E-CELL PLUS is also scheduled for release, which will include a small internal combustion engine combined with a generator to increase the range of the electric vehicle.

But that is not all: under the banner “Design for Environment”, we also look at a vehicle's entire lifecycle and work hard to preserve the environment from the planning stage right through to recycling. The same applies to the building and running of new plants. In addition, we are heavily involved in the development of alternative fuels and carry out research in the field of bionics. In short, BlueEFFICIENCY is good news for both you and the environment.

Further information about our comprehensive measures can be found at:  
[www.mercedes-benz.com/blueefficiency](http://www.mercedes-benz.com/blueefficiency)



## A show of strength at the filling station as well as out on the road

The SL 300 makes no compromises when it comes to driving enjoyment. The 6-cylinder unit developing 170 kW boasts a peak torque of 300 Nm. What's more, it is exceptionally torquy between 2500 and 5000 rpm.

As you get in and start the engine, your pulse quickens. And that's the way it stays. Even after the drive. The feel-good factor continues when you look at the fuel gauge. That's because the SL 300 is extremely economical on fuel – not least thanks to a longer rear-axle ratio of 3.07.

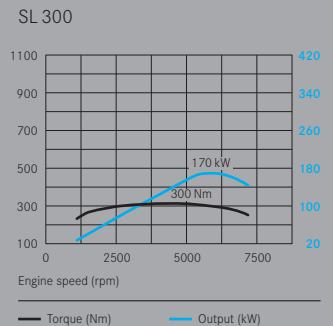



# Prepare to power through

The only thing you may have difficulty doing with your SL 350 is leaving it alone. The mere act of starting the 6-cylinder engine developing 232 kW and a peak torque of 360 Nm sets your pulse racing immediately. Acceleration on the road is equally impressive: from 0 to 100 km/h in just 6.2 seconds.

The sports engine draws its enormous power reserves from the depths of its 3498 cc displacement thanks to a

higher compression ratio and the cylinder head with an optimised intake duct. Furthermore, enhanced air supply and airflow have a positive effect on combustion as well as being two of the principal reasons behind the SL 350 model's outstanding flexibility, lower fuel consumption and reduced CO<sub>2</sub> emissions. The smooth-running powerplant produces a full and rich note. Indeed, the SL 350 sounds just as a true V6 sports car should, with visual confirmation provided by the red V on the engine itself.

SL 350

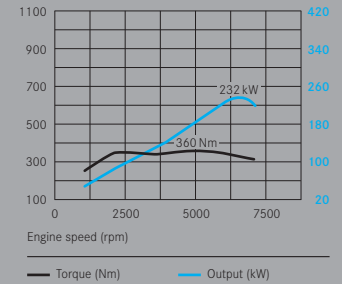



## A virtuoso V8 performance

The power announces itself with an unmistakable 8-cylinder baritone. You can feel the sheer potential of the SL 500 the moment the engine is started. The maximum output of 285 kW is achieved with a level of refinement that is almost without parallel. And with a peak torque of 530 Nm, the SL sprints effortlessly from 0 to 100 km/h in 5.4 seconds.

A special cylinder head was designed for the V8 engine to enable it to achieve these impressive figures: two intake valves and two exhaust valves per cylinder are controlled by means of infinitely variable camshaft adjustment. The result is optimal combustion which, as well as reducing fuel consumption and emissions, boosts the sports car's output and enhances your driving enjoyment. And even if you stop short of taking it to the limit, every drive in the SL 500 is a delight for all the senses. Whether it takes you on long, straight stretches in the country, over cobbled city streets or up twisting mountain roads.

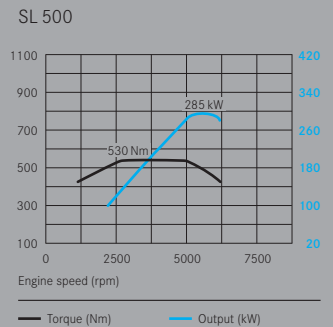





## A heart with twelve chambers: perfect for pumping out the power

12 cylinders and two letters – the SL 600. An icon of refinement. But to really make a mark, the figures have to stack up: 380 kW, a peak torque of 830 Nm and, above all, acceleration from 0 to 100 km/h in a breathtaking 4.5 seconds.

The V12 engine draws its power from a combination of two turbochargers and an intercooler. A consummate blend of sophisticated Mercedes-Benz engine technologies makes for outstanding responsiveness and maximum torque at low revs, yet still offers lower fuel consumption, not to mention a healthy dose of happiness hormones. Because the sensation of effortless ease you feel as you power ahead in the SL 600 turns every trip into a thoroughly enjoyable driving experience.

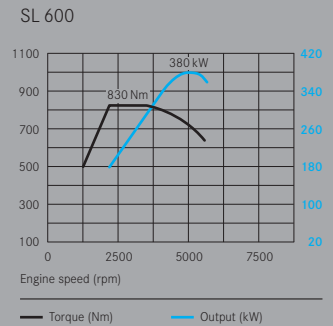





You can't help  
but be moved.  
Even after you stop

## Each gear change merely adds to the driving pleasure

With the very best automatic transmissions, you barely notice the gear changes. So it will come as no surprise that the jumps in engine speed when the 7-speed 7G-TRONIC changes up or down are smaller. And when moving down through the gears, the multiple downshift capability allows several gears to be skipped at once, making for extremely powerful acceleration in any gear.

The 7G-TRONIC is specified as standard for the SL 300, SL 350 and SL 500. These three models also come with

the option of the 7G-TRONIC Sport, which allows manual gear changes as well via steering-wheel gearshift paddles. If you keep the paddle pressed when shifting down, your SL will select the gear offering the best acceleration automatically. The SL 63 AMG is fitted with the AMG SPEEDSHIFT MCT 7-speed sports transmission, which changes gear exceptionally quickly without any interruptions in tractive power, thus ensuring the ultimate in driving enjoyment, even when the road speed is fluctuating wildly.

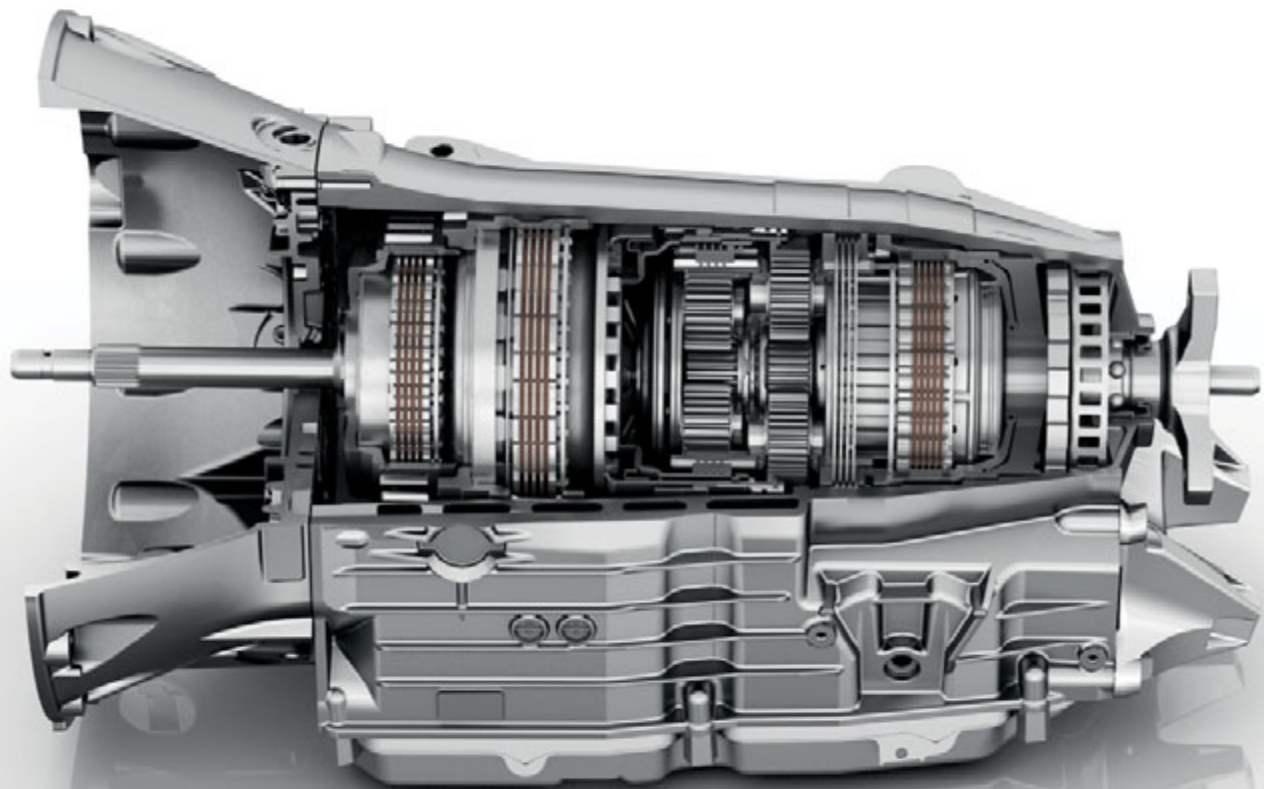

# Good contacts are essential if you spend a lot of time on the road

We don't stop developing a sports car the minute we finish the wheels or the exhaust tailpipes. The road is also part of the perfect driving experience. This is why, when developing Active Body Control ABC, we factored the road into the equation. ABC is specified as standard for the SL 500, SL 600 and SL 63 AMG models or available as an optional extra for the SL 350.

Ten sensors monitor the driving situation at all times. Hence body movements when setting off and braking are minimised, while lateral movements during cornering are reduced. In sporty mode, the response is enhanced, the

suspension configuration is tauter and the tilting angles are reduced even further. All of which makes for better handling dynamics and improved safety – for example when performing evasive manoeuvres at speed. Safety is also enhanced by the Electronic Stability Program ESP®, which acts as a continuous monitoring system and is included as standard on board all Mercedes models. Sensors record driver and vehicle behaviour and then send the gathered data to a microprocessor which, in turn, intervenes by sending specific braking pulses to the individual wheels in critical driving situations.



# The most direct link between the road and the nerve tract

Innovative technology gives you an instinctive feeling for the road, making piloting the SL a sheer, unadulterated pleasure. The standard-fit speed-sensitive power steering does an excellent job, making the car extremely easy to steer when parking, for example, as well as ensuring outstanding straight-line stability when travelling at speed.

The optionally available Direct-Steer system has an even more direct ratio when negotiating tight bends and when parking or manoeuvring. It reduces the steering wheel movements required and, therefore, enhances both comfort and safety. Furthermore, there are fewer steering-wheel turns from lock to lock. What makes the Direct-Steer system so impressive is the fact that you barely notice its presence. Only the ease with which you are able to control your SL gives an inkling that it is there.

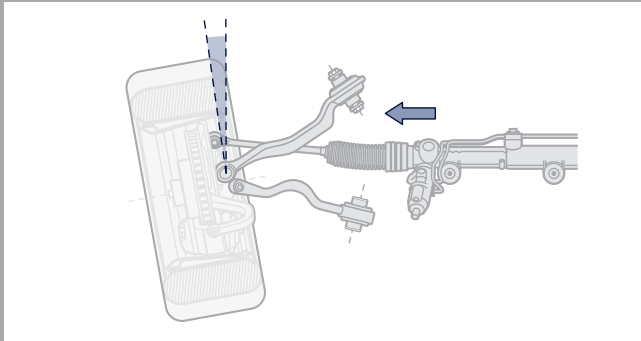

Wheel turn without the Direct-Steer system

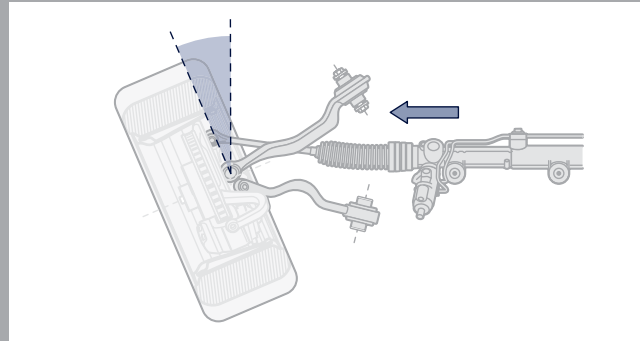

Wheel turn with the Direct-Steer system and the same steering wheel angle





## An idea you'll warm to

Travelling in an SL with the top down is an experience that will never leave you cold – especially when your vehicle is equipped with the innovative AIRSCARF system developed by Mercedes-Benz and available as an option. At the touch of a button, fans at the rear of the head restraints suck in air which is then heated and expelled through an outlet at the front of the seat. Three AIRSCARF settings allow you to adjust the system for optimum comfort in accor-

dance with your personal preferences, your driving style and the weather conditions. At high speeds, or in cold weather, you can just turn up the system to provide more heat. The air then gently wraps itself around the nape and front of your neck and head area like a warm scarf. And that means you can extend the roadster season for quite a while longer.

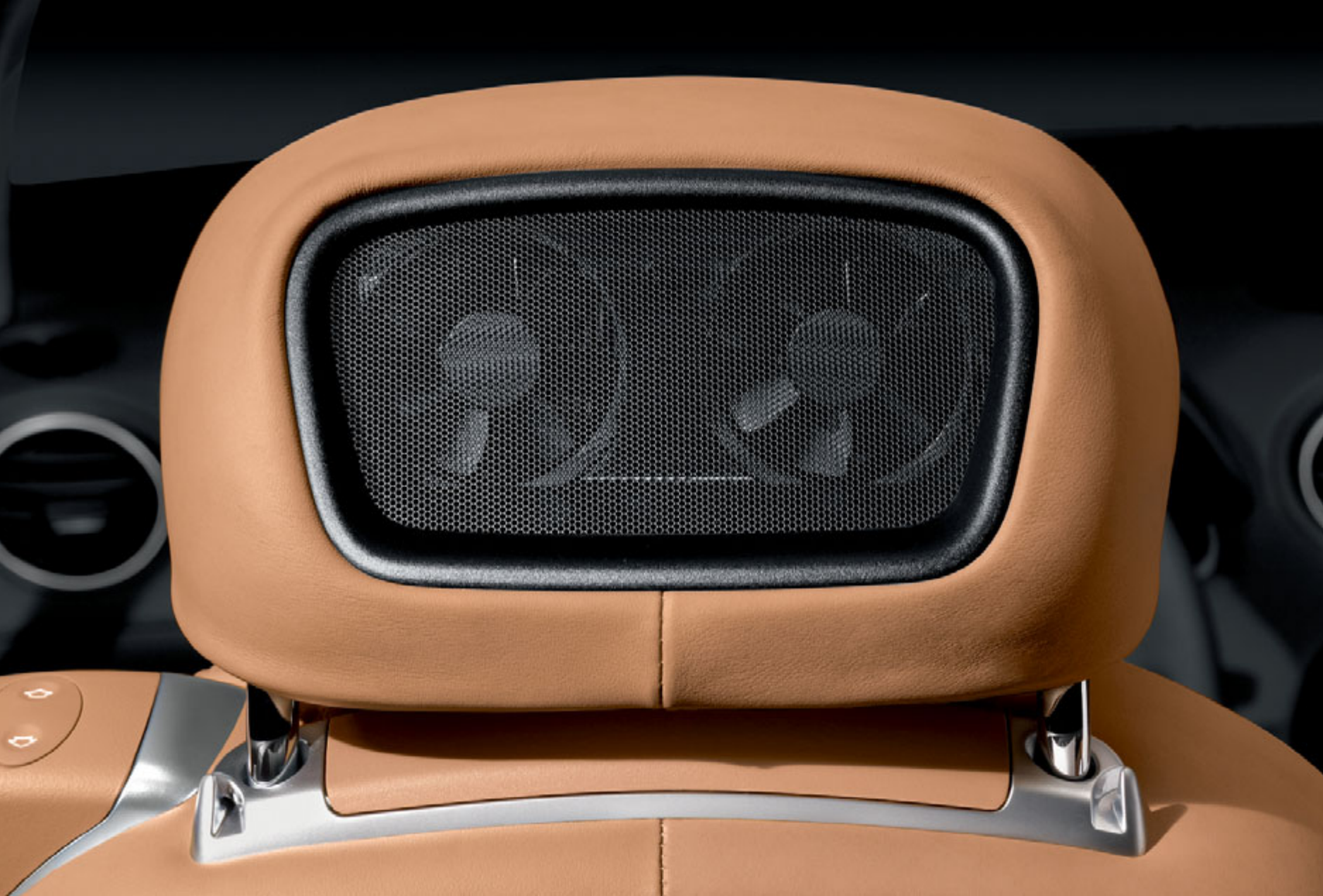



With the right roof, there's no such thing as the wrong weather



The vario-roof is the crowning glory of the SL's outstanding all-round performance, transforming the car into a roadster within a matter of seconds – just 16 to be precise. Thanks to the space-saving design, there are still up to 235 litres of boot capacity available when the roof is stowed in the

rear. This rises to 339 litres when the roof is up. But this Mercedes-Benz invention is not just about providing plenty of space for luggage. When the roof is closed, the quietness makes it feel like you are ensconced within a coupé. Noise, dangers, wind and weather simply remain outside. In fact,

the only thing that can top the vario-roof is the panoramic vario-roof. The latter features glass in place of the metal construction, allowing you to enjoy a view that is normally only afforded by a roadster, whilst still revelling in the comfort of an enclosed coupé – in practically any weather.



## Normally only a joystick assures this degree of control and precision

The refined sportiness of the SL allows you to experience a whole lot more in addition to the sporty drive. With both hands on the racily designed 3-spoke sports steering wheel trimmed in high-grade nappa leather. Not only does it look dynamic, it also lets you change gear extremely quickly courtesy of a paddle on either side. As well as being sporty, the SL interior boasts an exclusive wood, aluminium or carbon-fibre trim and softly grained leather appointments.



## Needles that are just itching to move

Exclusive dynamism is also a key theme of the SL interior. In terms of design, the 3-D instrument cluster owes much to the world of motor racing. The needles are initially dormant in the 6 o'clock position. Yet they spring into life the moment you insert the key and switch on the ignition, spinning around their respective dials before returning to the 0 rpm and 0 km/h positions - ready to spring into action at your command.







Some things that are exciting to watch in action look just as good when they are at rest. The needles are part of the newly designed 3-D-look, chronograph-style instrument cluster. The leather-style trim is embellished with fine top-stitching, while the racy 3-spoke sports steering wheel sits perfectly in the sporty surroundings of the SL's cockpit. Steering-wheel gearshift paddles are standard on the SL 600, the SL 63 AMG and with the Sports package, while all other models can be equipped with them as an optional extra.



## Two all-weather sports seats

The laterally reinforced integral seats in the SL turn even a marathon into pure pleasure, as your back gets all the support it needs on long journeys. Whether you are taking tight bends at speed or cruising serenely along, you are always in an optimum sitting position. Another reason for this is the meticulously crafted seat material, available in a choice of leather, nappa leather or Exclusive nappa leather.





The electrically adjustable seats let you alter your position with ease. The Memory function (optional for the SL 300) stores your preferred settings, so a flick of the wrist is all it takes to move the seats to your favourite position the next time you slide behind the wheel. Comfort is therefore assured. It's equally good to know that the standard-fit lumbar supports are behind you: these can be inflated or deflated by means of a thumbwheel to provide optimal support for the lower spine, giving you an alert, upright posture. When the weather turns colder, you'll also be pleased that the SL 500, SL 600 and SL 63 AMG models feature heated seats as standard, ensuring that your daily drive is a treat rather than a torture, even when things turn really frosty. Even the most unpleasant weather conditions cannot spoil your driving enjoyment. The SL 600 also has climatized seats fitted as standard, for pleasant cooling on extremely hot days.

## All legends share one thing above all: timelessness

The SL 600 model's 12-cylinder power is also clearly reflected in the interior. The steering wheel and the floor mats with V12 design and the finely embossed badges on the leather seats catch the eye the moment you get in, while the refined poplar wood trim and the Exclusive nappa leather appointments complement each other harmoniously. Even the heart of the most confirmed of perfectionists is sure to start racing



after beholding the wealth of harmonious details on display inside the 12-cylinder model. Such as the precise double topstitching and the discreet V12 emblems that hint at the power within, even when the car is stationary. Plus there is also the convenience of the KEYLESS-GO system, which allows you to fire the engine of your SL without having to use a key. Simply hit the start button. Further standard equipment available for the SL 600 includes remote boot lid closing, climatized seats and Convenience Telephony with hands-free system. So there can be no doubt: it's not just the 12 cylinders beneath the bonnet that make the SL 600 unique.



## An SL that hangs on your every word

The standard-fit COMAND multimedia system on board the SL groups together entertainment and navigation functions in one central unit. Optional navigation functions and films are shown on the 16.5 cm colour display. You can even watch television here if the optionally available TV tuner is specified. The 6-disc CD/DVD changer for audio or video is within easy reach, while an optionally available Media Interface allows COMAND to connect to any USB data source, an iPod® or Aux-in device. So you can play music or videos from an external hard drive, for example. The optional COMAND APS system already has an integral hard disc on which the navigation software is installed, leaving your CD drive free for other usage. There is also 4 GB





of memory for audio files in MP3 or WMA format. And if music isn't really your thing, you can have your SL entertain you in other ways. With LINGUATRONIC, the voice-operated control system, you can control the COMAND APS system's radio or telephone functions using spoken commands.



# The first concert hall able to go on tour

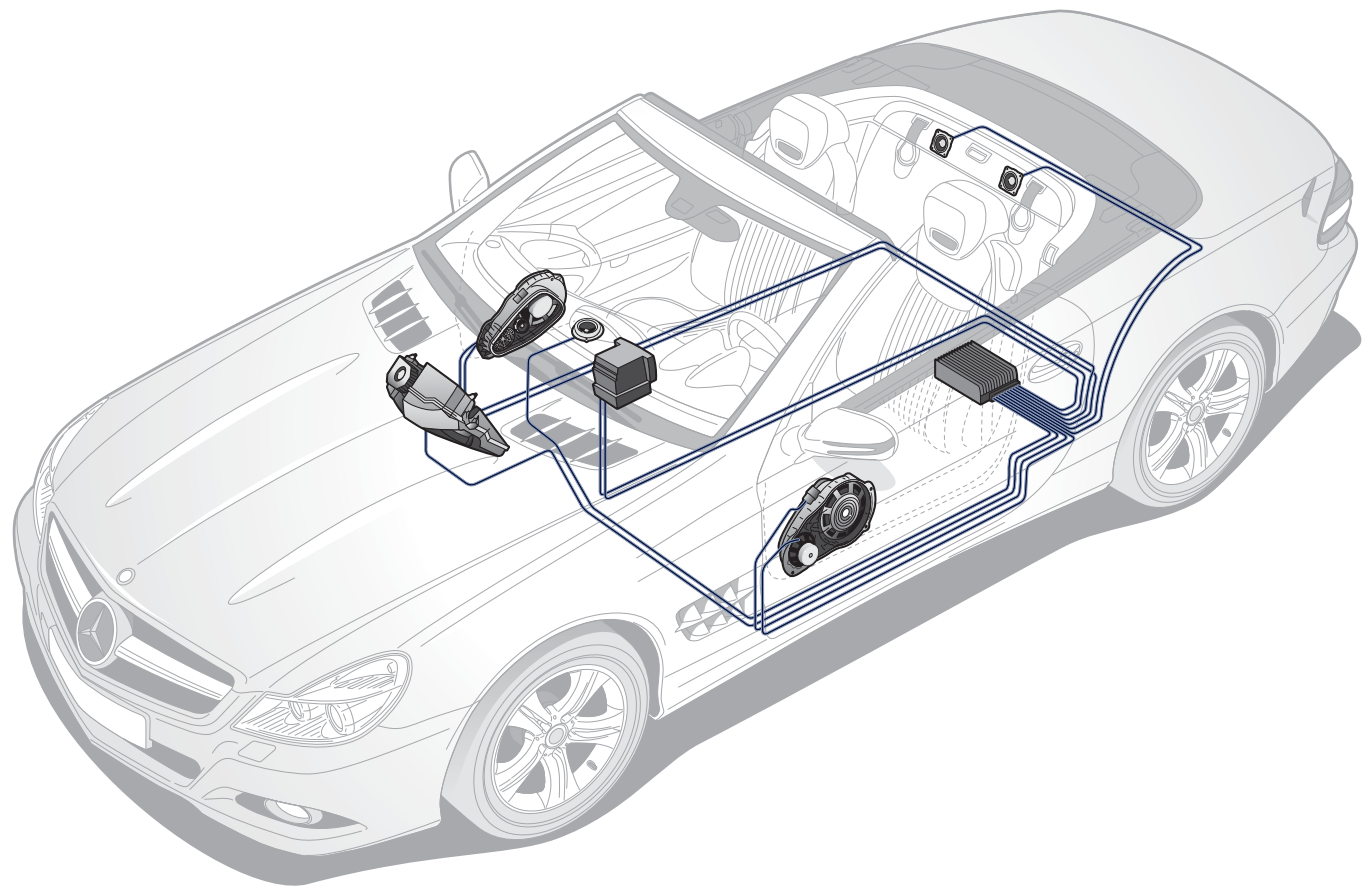





The SL seems almost too small to deliver such a monumental listening experience. The sound waves produced by the optionally available Harman Kardon® Logic 7® surround sound system fan out as in a concert hall thanks to ten high-performance loudspeakers, including two surround speakers and a subwoofer.

Allow the interior to flood with sound courtesy of Dolby digital technology – just like at the cinema. So should you on occasion wish to change the soundtrack provided by the 6-, 8- or 12-cylinder powerplant, you can always turn to the audio system.

## Only one thing is ahead of you in the SL: the safety systems

It all began with an invisible revolution. When Mercedes-Benz unveiled the first car to be designed with passive safety aspects in mind in 1959, the innovations – crumple zones and the safety passenger cell – were invisible to the naked eye. Then airbags and seat belt tensioners – both world firsts – came along. Since then, of course, we have never let up in our quest to always go one step further than required when it comes to safety. Should you have an accident today, sophisticated, efficient occupant protection systems help reduce the risk of injury dramatically. Self-protection is also enhanced by the high-strength safety passenger cell and systems such as adaptive airbags. And if the worst comes to the worst, the roll-over bar can pop up automatically within a fraction of a second.

The SL even helps to provide greater safety after an accident, for instance with a fuel tank situated in a protected position ahead of the rear axle, or the automatic engine cut-off function which is triggered after a severe collision. Automatic activation of the hazard warning lamps makes it easier to locate a car which has been involved in an accident. And doors which unlock automatically and are easily opened mean that occupants can be rescued more quickly after an accident.



ABS ensures that the car remains directionally stable and steerable, even during emergency braking. The driver is able to brake and steer simultaneously – allowing precise evasive manoeuvring – in order to avoid an accident

ESP® enables outstanding directional stability and road adhesion by counteracting any possible tendency to skid at the outset. It intervenes in the engine-management and braking systems as required in order to stabilise the car

Electronic control of the braking system allows a wealth of key assistance functions that help to further enhance active safety and comfort in a whole range of driving situations, thus making life much easier for the driver

During emergency braking, BAS ensures that the maximum brake pressure is applied within a fraction of a second, even if the brake pedal is not pressed hard enough. The stopping distance can therefore be shortened by a substantial margin



## Only two seats. But a wealth of assistance systems

Even the most enjoyable of journeys can come to an abrupt end. Now you can continue on your way, even after an emergency stop, thanks to the hundreds of sensors on board the SL. Such as the electro-hydraulic braking system's which monitor driver and car behaviour on a permanent basis. In critical situations, the pressure in the brake lines is increased and the pads are applied on the brake discs. A push of the brake pedal is then all that is needed to decelerate the SL with the full braking power. In addition, the braking system increases safety when braking on bends and can detect wet road surfaces. It brakes the brake discs dry when required and also reduces the pitching motion of the brake pedal when the anti-lock braking system ABS intervenes to counteract locking-up of the wheels by delivering the brake pressure in short bursts. This means that you remain firmly in control, even in the most precarious of situations. The Electronic Stability Program ESP<sup>®</sup> also applies the brakes at each individual wheel as required to assist with the prevention of tail-skids, oversteer or understeer, while Brake Assist (BAS) helps to shorten the braking distance. BAS can detect emergency braking and helps to provide the maximum braking power within a fraction of a second. Meaning that the car comes to a halt – and hopefully continues on its way again afterwards – in as short a time as possible.

# Flexible lighting to keep you on the move in the dark

Extremely sporty yet safe driving requires all your senses to be alert. Plus you need reliable sensors that help to detect possible dangers at an early stage. Active components of the safety concept include extremely powerful lights such as the bi-xenon headlamps specified as standard for the SL. The optional Intelligent Light System also includes an integrated cornering light function.

They illuminate the road far more effectively than conventional halogen lights, allowing you to see much further ahead and giving you a better perspective. All of which makes for much safer driving at night. So there's no need to be afraid of the dark.

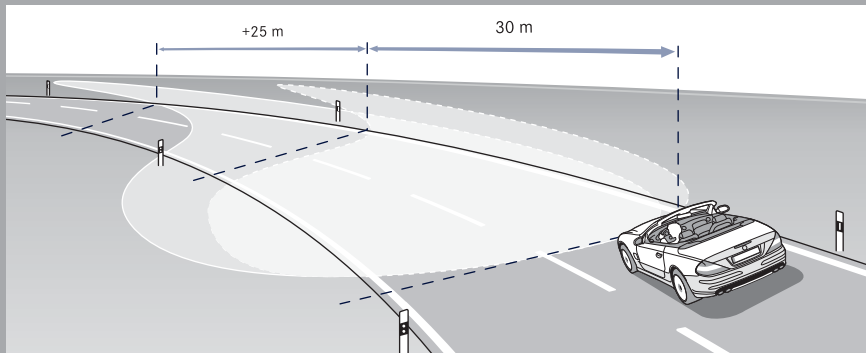



Pure power that  
makes you go weak  
at the knees









## AMG: the name speaks volumes; the performance speaks for itself

In a show of strength, the AMG bodystyling accentuates the muscular forms of the SL 63 AMG perfectly.

The exterior of the super sports car is dominated by the impressive AMG bonnet at the front and the dynamic AMG spoiler lip at the rear. The design comes to a rousing conclusion in the shape of an AMG sports exhaust system with two chromed twin tailpipes.

The SL 63 AMG boasts triple-spoke AMG light-alloy wheels with 255/35 R 19 front tyres and 285/30 R 19 rear tyres. AMG high-performance brakes with compound brake discs and 6-piston callipers are visible behind the front wheels. What's more, the brakes back up their powerful looks by delivering maximum performance – all in true AMG style.



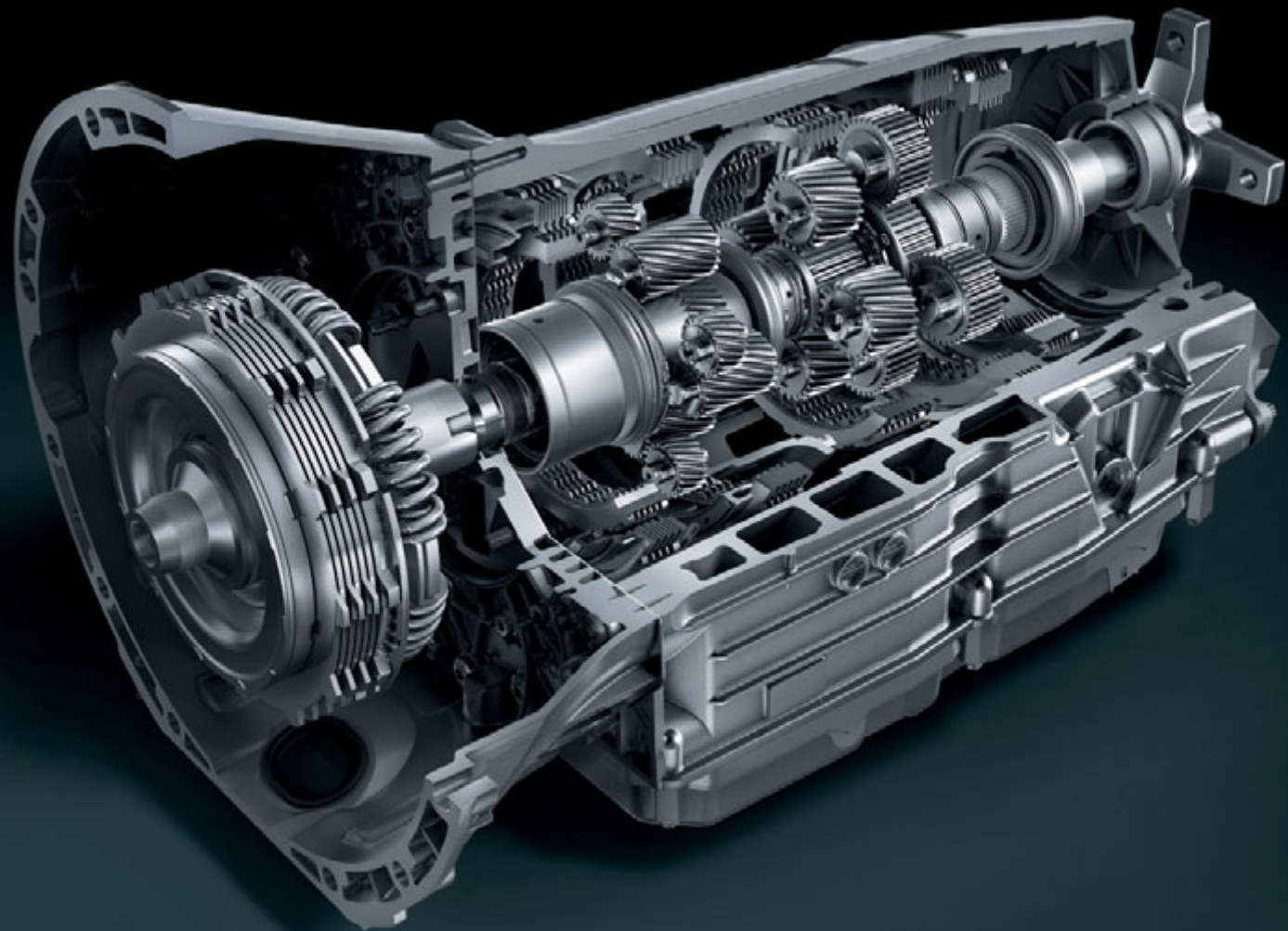



## Short on shift times, long on driving pleasure

The SL 63 AMG takes your breath away and makes you forget any everyday woes. Its large-displacement AMG 6.3-litre V8 engine develops 386 kW and delivers a peak torque of 630 Nm. This is handled with consummate ease by the innovative AMG SPEEDSHIFT MCT 7-speed sports transmission, which offers you a choice of four modes, ranging from dynamic manual shifts to comfortable cruising. So you ultimately decide how the formidable power of the SL 63 AMG is to be unleashed.

These features, like all the other dynamic handling control functions, can be controlled centrally thanks to the AMG DRIVE UNIT.

Furthermore, the AMG sports transmission features a Race Start function for optimal acceleration and traction – just as in the world of motorsport.







## Choosing the SL could be the easiest decision you'll ever have to make

The ability to combine sportiness and dynamism at the highest level is one of our greatest strengths. And nowhere is this demonstrated more perfectly than at the AMG Performance Studio – home to the Affalterbach individualisation experts. The AMG Performance package for the SL 63 AMG features components that have been specially configured for maximum performance: performance suspension, larger compound brake discs at the front and a rear-axle differential lock. Not to mention the twin-spoke AMG forged wheels and the more compact AMG performance steering wheel trimmed in nappa leather with its flattened bottom section.



The AMG Exterior Carbon Fibre package is designed primarily to enhance visual expressiveness. It features side air outlets, exterior mirrors, a spoiler lip and a diffuser insert made from carbon fibre as well as optional AMG door sill panels with white illumination.



D S 0U 9353





## The only racing attire that also looks good at a business meeting

SL Roadsters have always attracted admiring glances, an effect which can be boosted by adding AMG bodystyling. It consists of a powerful front apron with larger cooling-air intakes and integrated fog lamps, side sill panels and a rear apron with a black insert. The dynamic look is completed by 5-spoke AMG light-alloy wheels.







My SL



The Sports package



Some athletes are happy to just take part. Others are there to win. The SL with the Sports package falls into the latter category. The package is available for the SL 300, SL 350 and SL 500 models. Visual enhancements include 5-twin-spoke light-alloy wheels as well as darkened headlamps and tail lights, while the braking system features perforated front and rear discs along with painted callipers –

ready to provide maximum deceleration. The 7G-TRONIC Sport automatic transmission and steering-wheel shift paddles allow extremely fast gear changes, with the ratio offering the best acceleration being selected straight away every time. It feels good. And it sounds good too – thanks to the sports air filter developed specifically for the SL 300 and SL 350.



Enough sport for an entire team



What the SL with the Sports package promises on the outside is delivered on the inside: exclusivity and sportiness at the highest level. Starting with the black leather appointments with silver contrasting stitching. A design element that ensures clear accentuation, it embellishes the centre console, dashboard, armrests and the velour floor mats as well. Without the eye-catching stitching, the grey leather



appointments impress instead with their discreetly understated look. In both variants, the steering wheel and selector lever are trimmed in perforated nappa leather, their easy-grip design enhancing the feel of high quality. This unique interior look is enhanced by a prism-pattern aluminium trim that creates a pleasing contrast which is further accentuated by the black roof lining.



Exterior mirror



Draught-stop



Three-spoke sports steering wheel in nappa leather



COMAND display in the centre console



**Standard equipment (selection)**

Active Body Control ABC (optional for SL 350, not available for SL 300)
Adaptive brake lights incorporating LED technology
Airbags for driver and passenger plus head/thorax sidebags
Anti-theft alarm system with tow-away protection
Armrest/centre console with stowage compartment
ASSYST service interval indicator
Automatic climate control with combination filter and residual heat utilisation
Automatic transmission
Bi-xenon headlamps with headlamp cleaning system and dynamic beam control
Brake Assist (BAS)
COMAND with integral radio, 16.5 cm colour display with DVD changer, MP3-compatible, Bluetooth® interface, Aux-in socket, 8 loudspeakers
Cruise control with SPEEDTRONIC variable speed limiter
Draught-stop (optional extra for SL 300)
Electrically adjustable seats, with lumbar support and Memory function (optional extra for SL 300)
Electrically adjustable steering column, with Memory function (optional extra for SL 300)
Electro-hydraulic braking system with start-off assist
Electronic Stability Program ESP®
Exit lights in the doors
Headlamp Assist

Heated exterior mirrors, electrically adjustable, with aspherically curved mirror glass
Indicator repeaters in the exterior mirrors
Infrared remote control for roof
Light-alloy wheels
Loading aid for the boot (EASY-PACK system)
Metal door-sill panels
Multifunction steering wheel
Outside temperature display
Parcel net in passenger footwell
Power socket (12 V) in boot
Rain sensor
Remote boot lid release
Removable luggage cover
Roll-over bar with crash sensor, automatically raised
Seat belt tensioners and belt force limiters for driver and front passenger
Speed-sensitive power steering with safety steering column
Steering wheel and selector lever in nappa leather (wood/nappa leather in SL 600)
Tinted windows all round
Tyre pressure loss warning system
Ventilated glove compartment

## SL light-alloy wheels

A wide range of wheels is available for the different engine versions of the SL. 5-spoke light-alloy wheels are standard for the SL 500, while the SL 600 is delivered with ex-factory V12-design light-alloy wheels. 5-twin-spoke light-alloy wheels are available as optional extras for the SL 300, SL 350, SL 500 and SL 600. Plus distinctive 5-twin-spoke light-alloy wheels are fitted as standard in conjunction with the Sports package or as an optional extra for the SL 600.



5-spoke light-alloy wheels with 255/45 R 17 tyres (standard for SL 300)



5-twin-spoke light-alloy wheels with 255/45 R 17 tyres (standard for SL 350)



5-spoke light-alloy wheels with 255/40 R 18 tyres (standard for SL 500)



5-twin-spoke light-alloy wheels, with high-shine finish, with 255/40 R 18 front tyres and 285/35 R 18 rear tyres (optional extra)



V12-design light-alloy wheels with 255/40 R 18 front tyres and 285/35 R 18 rear tyres (standard for SL 600)



5-twin-spoke light-alloy wheels with 255/35 R 19 front tyres and 285/30 R 19 rear tyres (standard with Sports package, optional extra for SL 600)

## The AMG and incenio light-alloy wheels for your SL



5-spoke AMG light-alloy wheels, with high-shine finish, with 255/35 R 19 front tyres and 285/30 R 19 rear tyres



Triple-spoke AMG light-alloy wheels with high-shine, titanium-grey painted finish, with 255/35 R 19 front tyres and 285/30 R 19 rear tyres (standard for SL 63 AMG)



Twin-spoke AMG forged wheels in polished, titanium-grey painted finish, with 255/35 R 19 front tyres and 285/30 R 19 rear tyres (optional extra for SL 63 AMG)



incenio "Gorgona" 5-spoke light-alloy wheels<sup>1</sup> for 255/45 R 17 tyres



incenio "Veseli" 5-twin-spoke light-alloy wheels<sup>1</sup> for 255/40 R 18 front tyres and 285/35 R 18 rear tyres



incenio "Nash" 9-spoke light-alloy wheels<sup>1</sup> for 255/40 R 18 front tyres and 285/35 R 18 rear tyres



incenio "Tarka" 5-spoke light-alloy wheels<sup>1</sup> for 255/35 R 19 front tyres and 285/30 R 19 rear tyres

<sup>1</sup> incenio light-alloy wheels are supplied without tyres



We only ever adapt the SL to meet your needs



The SL features extremely comfortable, laterally reinforced integral seats that adjust electrically with ease and remember your preferred sitting position thanks to the Memory function (standard in all models except the SL 300). An even more relaxing driving experience is available with the climatized seats, which are fitted as standard in the SL 600 and are optional for all other models.

The perforated seats are equipped with an active ventilation system for fast cooling. Optional multicontour seats (standard equipment for the SL 63 AMG) have integral air cushions that adjust to your body and also offer a massage function: air chambers pulsate gently at the touch of a button to ease tense back muscles.



AMG bodystyling: front apron



Head restraint with AIRSCARF



AMG bodystyling: rear apron



Intelligent Light System: headlamp



Optional extras (selection)	SL 300	SL 350	SL 500	SL 600	SL 63 AMG
7G-TRONIC Sport automatic transmission including steering-wheel gearshift paddles	●	●	●	–	–
AIRSCARF	●	●	●	●	●
AMG bodystyling	●	●	●	●	○
Active Body Control ABC	–	●	○	○	○
COMAND APS, including hard-disc navigation for digitalised regions of Europe, 4 GB MUSIC REGISTER, voice-operated control system LINGUATRONIC, SD card slot, DVD audio/video, 3 years of free navigation updates for map data (vehicle-specific, from date of first registration)	●	●	●	○	●
Direct-Steer system	●	●	●	●	–
DISTRONIC	●	●	●	●	●
Harman Kardon® Logic 7® surround sound system with 510 watts, 10 speakers and Dolby 5.1/DTS	●	●	●	○	●
Heated windscreen washer system	●	●	●	●	○
Intelligent Light System including cornering light function	●	●	●	●	●
KEYLESS-GO	●	●	●	○	●
Media Interface: universal interface for various audio devices (e.g. iPod®, USB memory device, etc.)	●	●	●	●	●
Memory package for both front seats, steering column and exterior mirrors	●	○	○	○	○
Multicontour seats, left and right	●	●	●	●	○
Panoramic vario-roof	●	●	●	●	●
PARKTRONIC	●	●	●	○	●
Sports package	●	●	●	–	–
TV tuner (for analogue and digital TV reception)	●	●	●	●	●
Tyre pressure monitoring system	●	●	●	●	●

● Optional extra    ○ Standard equipment    – Not available



Practical genuine accessories



The range of genuine Mercedes-Benz accessories includes a whole host of attractive, high-quality and useful items for your SL. Take the custom-made cradles for your mobile phones for instance: they can be interchanged quickly and easily and are available for all sorts of different mobile phone models.



The optional door sill panels remind you that you are getting into a very special breed of car every time the doors are opened, with their Mercedes-Benz lettering illuminated in white. Further details can be found in the accessories brochure. Alternatively, consult your Mercedes-Benz dealer for one-to-one advice.

A close-up photograph of a silver, oval-shaped button with a black border. The button is centered on a light-colored metal surface that is perforated with a regular grid of small, circular holes. The word "designo" is embossed on the button in a black, lowercase, serif font. The lighting is soft, creating a subtle shadow to the right of the button.

designo

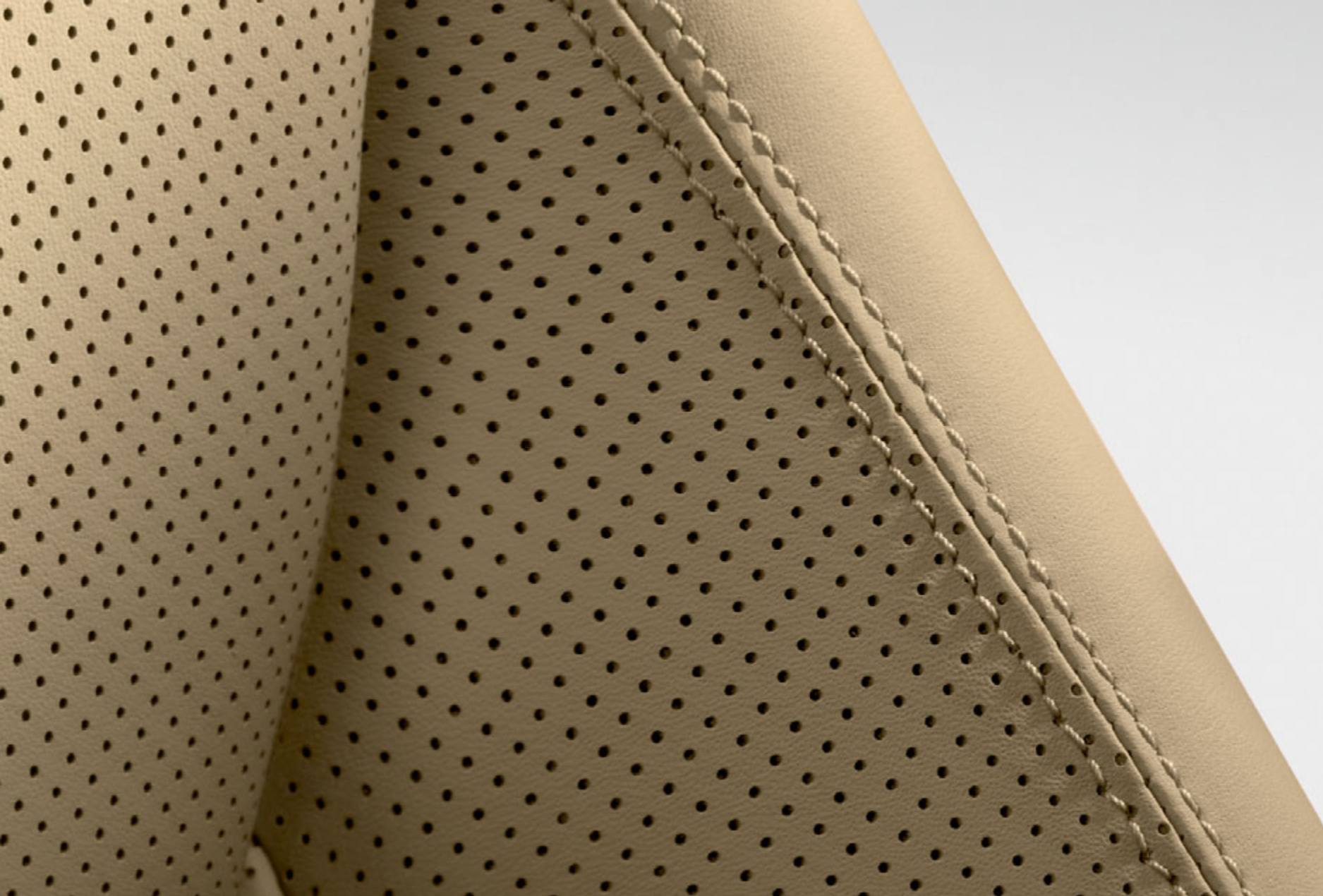

Inside, too, your wish is our command: eleven single-tone and two-tone designo leather upholstery finishes are available for the SL. But the choice of upholstery colour is only the first of many decisions. Would you prefer classic designo leather or the even finer designo Exclusive leather? We vary the Exclusive nappa leather appointments that form the basis for the designo upholstery effectively by adding touches in the selected designo colour, from the dashboard to the parcel shelf. A designo Alcantara® trim in a choice of three colours is available as an optional extra for the roof lining, A-pillars and C-pillars.

The range of designo trims comprises a choice of wood and fine natural stone options. Maple grain with a designo natural finish, designo black piano lacquer or oak grain with a designo matt natural finish lend the interior a warm atmosphere. By contrast, the labrador blue pearl and black Star Galaxy stone trims make an elegantly sporty statement. In addition, there are eleven exclusive designo metallic paints available, including four matt finishes. Further designo appointments and information can be found at [www.mercedes-benz.com/designo](http://www.mercedes-benz.com/designo)











Centre console in designo black piano lacquer (W69) with selector lever in designo black leather



Trim in designo black piano lacquer (W69), door centre panel with characteristic piping look in designo pastel yellow leather (X12)



# Anyone opting for a Mercedes buys far more than just a car

**Mercedes-Benz Museum.** 125 years of automotive history in one place – this is what awaits you at the Mercedes-Benz Museum in Stuttgart. Experience the unique excitement, and embark upon a thrilling journey through time. Housed inside an architecturally impressive building, over 1500 exhibits on nine levels give you an insight into the unique tradition and powers of innovation of the Mercedes-Benz brand. See the world's first two automobiles in the shape of the Benz Patent-Motorwagen (motor car) and the Daimler motorised carriage – both from the year 1886. Two linked circuits take you from the beginnings of the automobile, past a series of unforgettable classics and on to a glimpse of what the future holds – in an area covering a total of 16,500 square metres. Enjoy the unique brand experience. We look forward to your visit. Further details can be found at [www.mercedes-benz-classic.com/museum](http://www.mercedes-benz-classic.com/museum)

**MercedesCard.** The card is your ticket to the Mercedes-Benz experience. Four times a year, we will send you the Mercedes Magazine, featuring fascinating reports from the world of Mercedes-Benz and articles about our latest vehicles. A MercedesCard also has many other uses too. As a VISA credit card, it is an internationally accepted means of payment. Further benefits are available to provide you with peace of mind, such as insurance packages for your Mercedes and other insurance services for the whole family. You also get free entry to the Mercedes-Benz Museum simply by showing your VISA MercedesCard. Further details can be found at [www.mercedes-benz.de/mercedescard](http://www.mercedes-benz.de/mercedescard)<sup>1</sup>

**Mercedes-Benz Financial Services.** Mercedes-Benz stands for quality, innovation and safety – and the same applies to Mercedes-Benz Financial Services. Our innovative leasing and financing products are tailored to your financial needs and means, making it easy for you to secure the keys to your dream car. Once you are on the road, our insurance products offer you comprehensive protection on every trip. Finally, our service products ensure that your car is always in tip-top condition whilst keeping costs transparent and easily manageable. For a detailed quotation, please contact your Mercedes-Benz dealer, who will be glad to go through the latest financial services and terms and conditions with you.

<sup>1</sup> Information about the MercedesCard in Austria and Switzerland can be found on the Mercedes-Benz websites for these countries



**Mercedes-Benz mobility.** Your new car comes complete with the promise of feeling safe on the road, but if you should ever need assistance, then Mercedes-Benz Service24h is there to help. Just call the freephone service hotline on 00800 1 777 7777<sup>2</sup>. The newly integrated telematics service, Mercedes-Benz Contact<sup>3</sup>, is even more customer friendly: a touch of a button is all it takes to contact the Mercedes-Benz customer centre. If you wish, the relevant vehicle and position-related data can be transmitted at the same time, thereby allowing the centre to react quickly and provide rapid on-the-spot assistance. Also standard with your new car at no extra charge is the Mercedes-Benz Mobilo<sup>4</sup> mobility package. Whether you have lost your key, had a breakdown which cannot be repaired immediately or suffered damage to the vehicle due to an accident or vandalism, Mobilo is there to help you reach your destination – anywhere in Europe. Whatever your problem, one thing is certain: you will soon be able to resume your journey.

**Service packages.** Vehicle-specific services allow you to put together an individual package for your Mercedes, including long-term protection against unforeseeable repair costs and high-quality servicing with genuine Mercedes-Benz parts. You can also count on the extensive network of Mercedes-Benz workshops, where you will receive the usual high standard of service for your Mercedes at a predictable, fixed price. Please ask your Mercedes-Benz dealer for further details.

**Test drive.** The unique feeling of driving a Mercedes cannot be put into words. Which is why we'd like to invite you to experience it for yourself. Take a test drive and find out first hand how it feels to drive your dream car. Simply visit [www.mercedes-benz.com](http://www.mercedes-benz.com) to locate the nearest Mercedes-Benz dealer in your country or region.

**Interactive Owner's Manual.** The website also offers an interactive tour, enabling you to take a closer look at your desired model. These informative clips are the ideal way to acquaint yourself with your dream car. You can view key functions in detail, gain an insight into the car's inner workings or look at the benefits of each model. For further details, go to: [www.mercedes-benz.de/owners-manual](http://www.mercedes-benz.de/owners-manual)

**Mobile internet.** Now you can access the entire world of Mercedes-Benz from your mobile phone. As well as an overview of all the passenger car models, there are insights into the entire brand world along with a wealth of entertainment offers and direct links to our range of services at [www.mercedes.mobi](http://www.mercedes.mobi)

<sup>2</sup> Alternative: +49 69 95 30 72 77

<sup>3</sup> Requires a factory-fitted radio, connected to an operational mobile phone

<sup>4</sup> When the warranty has expired Mobilo can be extended by another year for a maximum of 30 years, provided that regular maintenance is carried out by your Mercedes-Benz service partner

A Mercedes embodies a real sense of freedom – something you’ll begin to experience when you specify your future car by choosing your ideal configuration from the wide range of possible combinations. If this seems a little daunting, we can help you – with our vehicle configuration tool at [www.mercedes-benz.de](http://www.mercedes-benz.de), for example. This allows you to take your time putting your Mercedes together in the form of a virtual model before ordering the real thing from us. Or you can opt for the almost unlimited freedom presented by the designo range and create an SL which reflects your tastes in every respect. Freedom is there to be embraced, after all.

	Leather/ Como fabric <sup>1</sup>	black	Leather <sup>2</sup> / Nappa leather <sup>3</sup> / Exclusive nappa leather <sup>4</sup>	black	natural beige	flamenco red	pebble beige	alpaca grey
<b>NON-METALLIC PAINTS</b>								
black		●		●	●	●	●	●
fire opal		●		●	○	△	○	○
<b>METALLIC PAINTS</b>								
magnetite black		●		●	●	●	●	●
obsidian black		●		●	●	●	●	●
indigolite blue		●		●	○	△	○	●
thulite red		●		●	○	●	●	○
tenorite grey		●		●	●	●	○	●
iridium silver		●		●	●	●	△	●
palladium silver		●		●	△	●	○	●
pearl beige		●		●	△	●	●	△
diamond white BRIGHT		●		●	●	●	○	●
<b>SPECIAL PAINT FINISH</b>								
alabandite grey		●		●	○	△	○	●

● Recommended    ○ Possible    △ Not recommended

<sup>1</sup> Standard for SL 300 and SL 350, not available for any other models

<sup>2</sup> Optional extra for SL 300 and SL 350, standard for SL 500

<sup>3</sup> Optional extra for SL 300, SL 350 and SL 500, standard for SL 63 AMG

<sup>4</sup> Optional extra, standard for SL 600

## TRIM

739 aluminium<sup>1</sup>H73 carbon fibre<sup>2</sup>H75 prism-pattern aluminium<sup>3</sup>

## WOOD

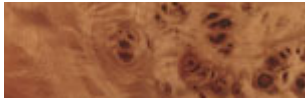
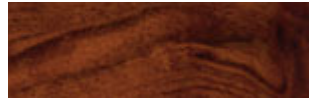
729 high-gloss light brown poplar<sup>4</sup>731 high-gloss brown burr walnut<sup>5</sup>736 high-gloss black ash<sup>6</sup>H12 high-gloss light brown burr walnut<sup>6</sup>

## designo ALCANTARA® ROOF LINING



Y83 designo anthracite



Y84 designo pebble beige



Y85 designo alpaca grey

## designo TRIM



W21 designo natural matt oak grain wood

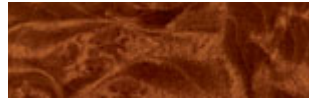

W64 designo natural maple grain wood



W69 designo black piano lacquer wood

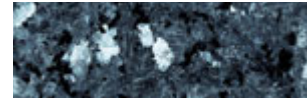

W72 designo labrador blue pearl stone



W73 designo black Star Galaxy stone

<sup>1</sup> Standard for SL 300 and SL 350, no-cost option for SL 500, not available for SL 600 and SL 63 AMG

<sup>2</sup> Standard for SL 63 AMG, not available for any other models

<sup>3</sup> Prism-pattern aluminium is part of the Sports package and not available separately

<sup>4</sup> Standard for SL 600, not available for any other models

<sup>5</sup> Standard for SL 500, optional extra for SL 300 and SL 350, no-cost option for SL 600 and SL 63 AMG

<sup>6</sup> Optional extra for SL 300 and SL 350, no-cost option for all other models

## LEATHER

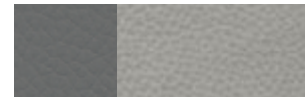
211 black<sup>1</sup>214 natural beige<sup>1,2</sup>215 pebble beige<sup>1</sup>217 flamenco red<sup>1</sup>218 alpaca grey<sup>1</sup>

## NAPPA LEATHER

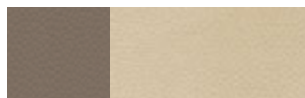
801 black<sup>3</sup>804 natural beige<sup>2,3</sup>805 pebble beige<sup>3</sup>807 flamenco red<sup>3</sup>808 alpaca grey<sup>3</sup>

## EXCLUSIVE NAPPA LEATHER

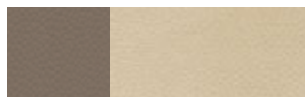
511 black<sup>4</sup>514 natural beige<sup>2,4</sup>515 pebble beige<sup>4</sup>517 flamenco red<sup>4</sup>518 alpaca grey<sup>4</sup>

## LEATHER/COMO FABRIC

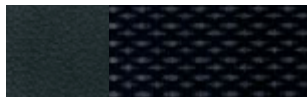
black<sup>5</sup>

## SPORTS PACKAGE

221 black leather<sup>6</sup>811 black nappa leather<sup>6</sup>521 black Exclusive nappa leather<sup>6</sup>

228 grey leather



828 grey nappa leather



528 grey Exclusive nappa leather

<sup>1</sup> Optional extra for SL 300 and SL 350, standard for SL 500<sup>2</sup> Not available for SL 63 AMG<sup>3</sup> Optional extra for SL 300, SL 350 and SL 500, standard for SL 63 AMG<sup>4</sup> Optional extra, standard for SL 600<sup>5</sup> Standard for SL 300 and SL 350, not available for any other models<sup>6</sup> Leather with silver topstitching



	SL 300	SL 350	SL 500	SL 600	SL 63 AMG
No. of cylinders/arrangement	6/V	6/V	8/V	12/V	8/V
Total displacement (cc)	2996	3498	5461	5513	6208
Rated output <sup>1</sup> (kW at rpm)	170/6000	232/6500	285/6000	380/5000	386/6800
Rated torque <sup>1</sup> (Nm at rpm)	300/2500–5000	360/4900	530/2800–4800	830/1900–3500	630/5200
Acceleration from 0 to 100 km/h (s)	7.8	6.2	5.4	4.5	4.6
Top speed <sup>2</sup> , approx. (km/h)	250	250	250	250	250
Tank capacity (l)/Fuel	80/Premium petrol	80/Premium petrol	80/Premium petrol	80/Super Plus	80/Super Plus
Fuel consumption <sup>3</sup> (l/100 km)					
Urban/Extra-urban/Combined	13.5/6.8/9.3	13.8/7.2/9.7	17.3/8.4/11.6	21.1/9.6/13.9	21.7/9.7/14.1
CO <sub>2</sub> emissions <sup>3</sup> (g/km), combined	217	226	272	326	328
Emissions standard	Euro 5	Euro 5	Euro 5	Euro 5	Euro 5
Kerb weight <sup>4</sup> (kg)/perm. GVW (kg)	1815/2110	1825/2120	1910/2205	2045/2320	1970/2225
Tyre size					
Front	255/45 R 17	255/45 R 17	255/40 R 18	255/40 R 18	255/35 R 19
Rear	255/45 R 17	255/45 R 17	255/40 R 18	285/35 R 18	285/30 R 19
Boot capacity,					
incl. luggage recess (l)					
Roof up	339	339	339	339	339
Roof down	235	235	235	235	235

<sup>1</sup> Figures in accordance with Directive 80/1269/EEC in the currently applicable version

<sup>2</sup> Electronically governed

<sup>3</sup> The figures shown for fuel consumption and CO<sub>2</sub> emissions were obtained in accordance with the prescribed measuring process (Directive 80/1268/EEC in the currently applicable version). The figures are not based on an individual model and do not constitute part of the product offer; they are provided solely for purposes of comparison between different vehicle models. These figures may vary in real-life operation

<sup>4</sup> Figures according to Directive 92/21/EC, version 95/48/EC (kerb weight with fuel tank 90% full, driver, 68 kg, and luggage, 7 kg) for standard-specification vehicles. Optional extras and accessories will generally increase this figure and reduce the payload capacity accordingly

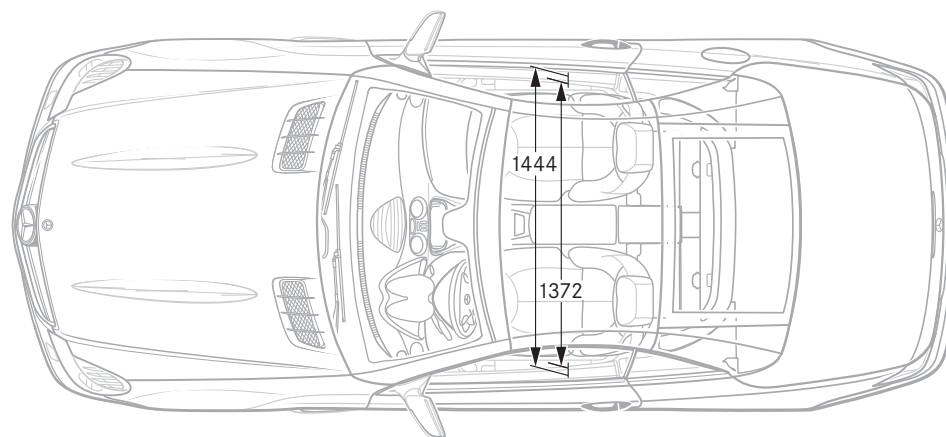
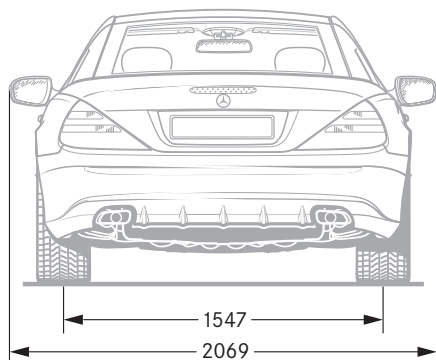
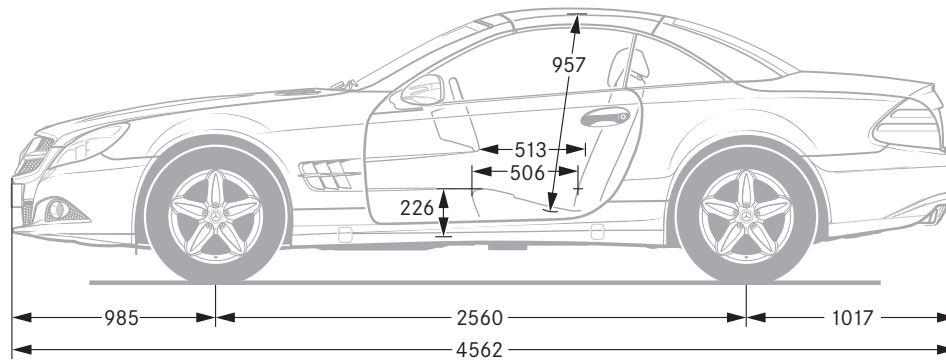
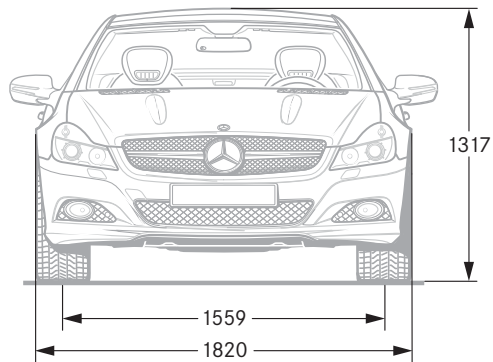

All measurements in millimetres. The dimensions shown are mean values and apply to standard-specification, unladen vehicles

NON-METALLIC PAINTS<sup>1</sup>

040 black



590 fire opal

SPECIAL PAINT<sup>2</sup>

779 alabandite grey

METALLIC PAINTS<sup>3</sup>

183 magnetite black

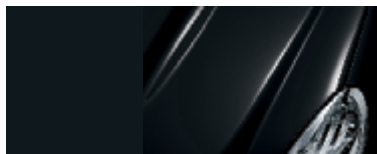

197 obsidian black



230 indigolite blue



541 thulite red



755 tenorite grey



775 iridium silver

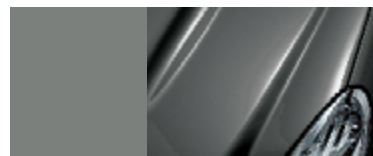

792 palladium silver



794 pearl beige



799 diamond white BRIGHT

<sup>1</sup> Standard<sup>2</sup> Option<sup>3</sup> Option, standard for SL 500 and above

**Take-back of end-of-life vehicles.** Coming full circle. At the end of its long life, you can return your SL-Class to us for environment-friendly disposal in accordance with the EU End-Of-Life Vehicle Directive<sup>1</sup>. But that day lies a long way off.

<sup>1</sup> Applies in accordance with national regulations to vehicles up to 3.5 tonnes gross weight. Mercedes-Benz passenger cars have met the statutory regulations governing the suitability of their design for reuse and recycling for a number of years now. A network of vehicle take-back depots and dismantlers has been established which will process your vehicle in an environment-friendly manner. The ways in which both vehicles and parts can be recovered are subject to ongoing development and improvement. Consequently, the SL-Class will be able to comply with any future increases in the recycling quota within the stipulated time limits. For further information: [www.mercedes-benz.com](http://www.mercedes-benz.com)

**Please note:** changes may have been made to the product since this brochure went to press (04.02.2011). The manufacturer reserves the right to make changes to the design, form, colour and specification during the delivery period, provided these changes, while taking into account the interests of the vendor, can be deemed reasonable with respect to the purchaser. Where the vendor or the manufacturer uses symbols or numbers to describe an order or the subject of an order, no rights may be derived solely from these. The illustrations may show accessories and items of optional equipment which are not part of standard specification. Colours may differ slightly from those shown in the brochure, owing to the limitations of the printing process. This brochure is distributed internationally. It provides a general indication of the range of models, features, optional extras and/or colours available in various countries. Some of the models, features, optional extras and/or colours may not be available in your country, or may only be available in a different specification. Additionally some models, features, optional extras and/or colours may only be available in combination with others. For current and more specific information in relation to the range of models, features, optional extras and/or colours available in your country, and their pricing, you should contact your nearest authorised Mercedes-Benz Passenger Car Dealer. [www.mercedes-benz.com](http://www.mercedes-benz.com)