

This Brochure is prepared by Daimler AG and it predominantly reflects the capabilities and performance of vehicles sold in Europe. Some characteristics, capabilities, performance features and optional extras (e.g. towing systems) may not be available or may not apply in Australia or under Australian conditions. The information in this Brochure is therefore indicative, illustrative and provided only for guidance and should not be relied on. To obtain current and accurate information on a vehicle and any options applicable to Australia, contact your local authorised Mercedes-Benz dealer.



Mercedes-Benz

The SLK-Class



Mercedes-Benz

er delivers what its design promises. Dynamism and agility are unparalleled, whilst the
the greatest of care, and sophisticated ergonomics. A single glance is sufficient: your
tiny salt crystals bursting beneath the powerful wheels. What follows is performance p
gut feeling. Like falling in love for the first time. Even after you've brought the SLK to
. As well as being built for the road, the new SLK is designed to thrill. You can see the
of having arrived with you when you hit the road. At last a roadster that even releases
. The stage is set for a premiere. Long bonnet, short overhangs, the visual focus far ba
ame Mercedes-Benz stands for the fact that it cuts just as fine a figure on the tarmac a
ts muscular appearance seems even more logical. Its dynamic silhouette even more ap
omes courtesy of numerous driver assistance systems, for instance. Here the art lies in
every journey. **Your closest relationship with the road.** Under a starlit roof. The new S
K symbolises roadster genes and sports car evolution, progress with maturity, style an



The new SLK: your closest relationship with the road. One look is all it takes: the forwards thrust is signalled loud and clear. Long bonnet, short overhangs, the visual focus far back. And as you drive the roadster delivers what its design promises. Dynamism and agility are unparalleled, courtesy of the suspension with its sporty tuning, a body designed to meet discerning requirements and the utmost attention to detail when it comes to the teamwork carried out by the engine and transmission. Powerful engines place a high torque at your disposal. Alongside the good response, impressive acceleration and ability to perform, the car is characterised by extraordinary efficiency, whilst the comfort and quality feel are hallmark Mercedes-Benz.

The interior sparkles with high-quality materials, processed with the greatest of care, and sophisticated ergonomics. Thanks to optional innovations such as AIRGUIDE, nothing more than a gentle breeze can now get in the way of pleasurable open-top motoring. And if it should rain, the new panoramic vario-roof with MAGIC SKY CONTROL enhances transparency even after closing time. The new SLK is also right out in front where handling safety is concerned: with lots of driver assistance systems and an extensive safety concept which was developed specially for the roadster.

At a glance | from page 4 Insight | from page 28

Featured models:

SLK 200 BlueEFFICIENCY | palladium silver metallic | Cover, from page 2
5-spoke light-alloy wheels, bengal red nappa leather, brushed aluminium trim

SLK 250 BlueEFFICIENCY | designo zircon red | from page 7
5-spoke AMG light-alloy wheels, black leather, brushed aluminium trim

The illustrations may show accessories and optional extras which are not part of the standard specification.

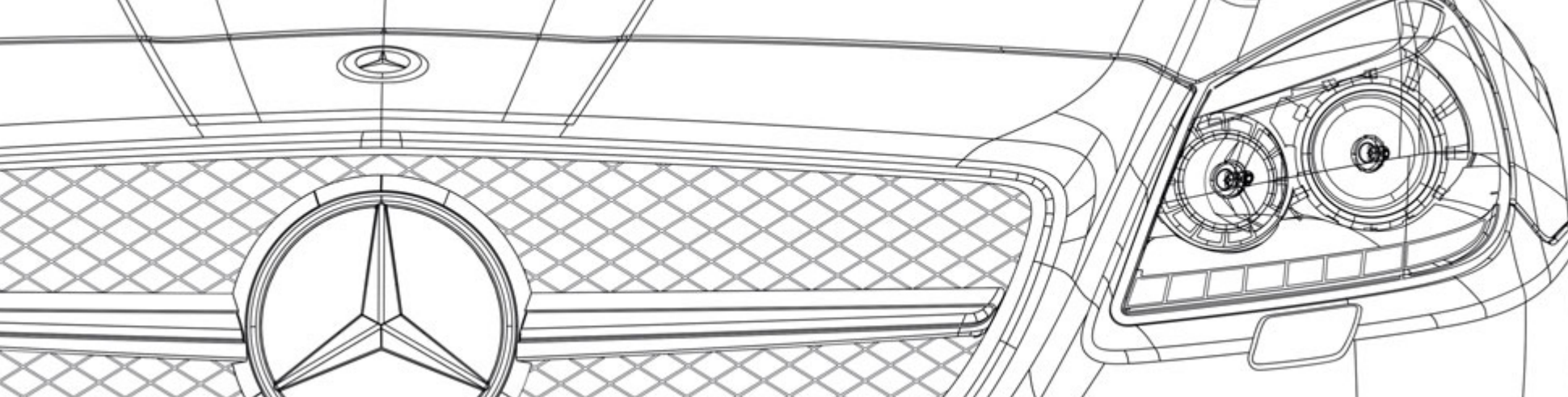

Motoring pleasure in top form: BlueEFFICIENCY, petrol engines, diesel engine, transmissions and chassis.

Drive system & chassis | from page 36

Maximum safety: state-of-the-art technologies which can act in advance to help prevent accidents, mitigate their possible consequences and facilitate rescue.

Safety | from page 44

Relaxed driving in the SLK: everything about multimedia and assistance systems, open-air comfort, roof variants and climate control, plus seats.

Comfort | from page 48

Exclusive V8 performance: SLK 55 AMG exterior, interior, technology and Performance Studio.

AMG | from page 54

A roadster with character: upholstery and trim, AMG Sports package, designo, standard equipment, optional extras, wheels and genuine accessories.

Equipment & appointments | from page 60

Star service: everything about the MercedesCard, Mercedes-Benz Financial Services, Mercedes-Benz mobility, Mercedes-Benz Museum, test drive, Interactive Owner's Manual, mobile internet, service packages and repair following an accident.

Services | from page 80

SLK in detail: dimensions, paintwork and technical data.

Facts & colours | from page 82



Precision driver meets
precision machine



Pepper for the salt lake



A single glance is sufficient: your pulse accelerates from 0 to euphoria in a few seconds. The new SLK symbolises roadster genes and sports car evolution, progress with maturity, style and intensity. And the name Mercedes-Benz stands for the fact that it cuts just as fine a figure on the tarmac as it does in the eye of the beholder.





A dab of the right foot – and the machine responds within fractions of a second. Like billions of tiny salt crystals bursting beneath the powerful wheels. What follows is performance par excellence. The dynamic suspension responds as if it were at one with the road. The driver's senses come alive. It's a gut feeling. Like falling in love for the first time.





One of the brightest stars

Even a wonderful day must come to an end at some point. And give way to an excitement-filled night. Even after the SLK has come to a halt, the happiness hormones still race from head to foot. Take a deep breath, get out and take another look at the roadster. After a drive in the SLK, its muscular appearance seems even more logical. Its dynamic silhouette even more appealing. As well as being built for the road, the new SLK is designed to thrill.





A view from inside a car looking out at a sunset over a body of water with mountains in the distance. The sun is low on the horizon, creating a warm, golden glow. The water is dark with whitecaps, and the mountains are silhouetted against the bright sky. The car's interior is visible in the foreground, including the roof and side panels.

Tight bends, long stretches and ambitious driving manoeuvres – the SLK’s requisite effortless superiority comes courtesy of numerous driver assistance systems, for instance. They are in a position to assess attention levels, maintain distance and speed, and prepare braking manoeuvres. And they are mostly active before you even know you need them.



You can see the fire in its eyes



A high-angle, close-up photograph of the driver's side interior of a red Mercedes-Benz sports car. The steering wheel is black with a perforated leather grip and features the Mercedes-Benz logo in the center. The instrument cluster behind the wheel includes a tachometer, a speedometer, and a central digital display showing '0.6', '29', and '24.0°C'. The dashboard and center console are black with silver accents and circular air vents. A red interior light is visible on the ceiling. The overall aesthetic is sleek and performance-oriented.

1.2 cubic metres: all you need to hone your own driving style

It's great when you can take the feeling of having arrived with you when you hit the road. The sports steering wheel fits comfortably in your hands. The functions can be used almost intuitively, the seats feel like they have been designed around you. Here the art lies in making something so highly practical so easy on the eyes.



At last a roadster that even releases endorphins when you're refuelling

Sunshine as far as the eye can see. Thirst is its constant companion. That doesn't impress the SLK very much. Lightweight construction, optimised engine technology – measures that pay. With more pleasure per tank and a better conscience with every journey.











Perfection from tip to toe

Feeling the wind blowing through your hair doesn't have to mean frozen ears. The roadster offers optional technical and aerodynamic features to ensure virtually draught-free open-top motoring - and that your hair still looks fabulous for your late-night dinner date.

Under a starlit roof

Summer night. The stage is set for a premiere. The new SLK proudly presents the sky – in the closed vehicle. It's all thanks to the panoramic vario-roof – also available with MAGIC SKY CONTROL as an option.









The ignition is at rest
but the passion burns on

An encounter comes to an end. At least for the time being. For the new SLK follows an extensive safety concept, with a reinforced body befitting a roadster, plus large headbags and crash-responsive head restraints. And something else is certain: you want to get in again and again.

What breed is your roadster?

Even before the invention of the car, a journey in a roadster was all about horsepower, for the term originally referred to specimens of the equestrian variety. To begin with, this was the name given to small combination consisting of one animal and a light, easily manoeuvrable open carriage for one person – similar to the trainer and sulky found on the race track today. The roadsters' job was to take their drivers from A to B as quickly as possible, comfort being merely a secondary consideration. So it was usually short sprints rather than lengthy trips that were undertaken in the roadster. Later on the term ennobled various breeds of horse which were specially bred for this task. They are characterised by stamina, high reliability, strength, speed and extreme elegance. To this day the Saddlebred bred in America is one of the best known “roadsters”.

Incidentally, the qualities that lie behind this term have not changed very much at all. It's just that the carriages of our times are moved by many horsepowers rather than just one, they offer room for two and are way more comfortable. Which is why they can also cover long distances speedily and comfortably. And last but not least, all you need to take control of a roadster today is a valid driving licence – the ability to keep a firm hold of the reins is not a prerequisite.



Let there be light – as much as you like

Anyone who has always wanted to be a master of light and shadow will find that the SLK with MAGIC SKY CONTROL is the perfect place for them. Because thanks to this innovative idea, it is possible to let sunlight in through a transparent roof – or to darken the car's interior. Through an electric impulse tiny crystals on a wafer-thin film between two layers of the panoramic roof position themselves in front of the sky. Depending on the desired intensity of sun, virtually 100% of the light can be let in – or up to 75% can be let out.

Incidentally, even when the roof is in its transparent state the summer heat remains largely outside, so drivers can decide whether they want to feel like they are in a closed vehicle or in the open air – at the touch of a button. The only thing the optional panoramic vario-roof with MAGIC SKY CONTROL can't do is make the sun shine.



Upholstery and trim. In an accident. Metallic paints. Sound system. Petrol engines. AMG
sion. Optional extras. Fuel consumption. Interior. In the event of danger. LED daytime
ESP[®]. Dimensions. Standard equipment. Light. Multimedia systems. Drive system. Gen
package. Transmissions. Surround sound system. Wheels. Interior. Safe driving. CO₂ e
trim. Assistance systems. BlueEFFICIENCY. In an accident. Metallic paints. Petrol eng
s. Top speed. Chassis & suspension. Optional extras. Fuel consumption. Interior. Airba
Facts and colours. Climate control. Seats. ESP[®]. Dimensions. Standard equipment. Lig
CO₂ emissions. Memory package. Transmissions. Surround sound system. Wheels. Inter
al data. Interior. Services. Safety. Assistance systems. Upholstery and trim. In an accid
. Safe driving. Light-alloy wheels. Top speed. Optional extras. Chassis & suspension. Fu
Engines. AMG. **The facts.** Paintwork. Total displacement. Climate control. Seats. Dime
ht-alloy wheels. Memory package. Transmission. Surround sound system. Wheels. Int

36 **BlueEFFICIENCY**37 **BlueEFFICIENCY in the SLK**38 **Petrol engines**

4-cylinder in-line engines

V6 engine

40 **Diesel engine**41 **Transmissions**

6-speed manual transmission

7G-TRONIC PLUS

42 **Chassis & suspension**

Sports suspension

Dynamic Handling package

with Adaptive Damping System ADS

Direct-Steer system

44 **Safe driving**

ATTENTION ASSIST

Intelligent Light System

DISTRONIC PLUS

ADAPTIVE BRAKE

Brake Assist BAS PLUS

46 **In the event of danger and in an accident**

Airbags

NECK-PRO head restraints

Active bonnet

PRE-SAFE® system

48 **Multimedia systems**

Harman Kardon® Logic 7® surround sound system

COMAND Online

Becker® MAP PILOT

49 **Assistance systems**

Speed Limit Assist

PARKTRONIC incl. Parking Guidance

50 **Open-air comfort**

AIRSCARF

Sun-reflecting leather

AIRGUIDE

51 **Roof and space**

Vario-roof

Panoramic vario-roof

Panoramic vario-roof with MAGIC SKY CONTROL

52 **Climate control and light**

Ambient lighting

Air conditioning system

THERMOTRONIC

53 **Seats**

Seats

Memory function

The SLK-Class in detail

54	SLK 55 AMG exterior	60	Upholstery and trim	80	Services	82	Dimensions
56	SLK 55 AMG interior	66	AMG Sports package		MercedesCard	82 85	Paintwork
58	SLK 55 AMG technology AMG 5.5-litre V8 engine AMG SPEEDSHIFT PLUS 7G-TRONIC automatic transmission	70	designo		Mercedes-Benz Financial Services Mercedes-Benz mobility Mercedes-Benz Museum	83	Technical data
59	AMG Performance Studio	72	Standard equipment		Test drive Interactive Owner's Manual Mobile internet Service packages Repair following an accident		
		74	Optional extras				
		76	Wheels Standard wheels Optional wheels AMG wheels Genuine-accessory wheels				
		78	Genuine accessories				

BlueEFFICIENCY – fast forward to tomorrow



Mercedes-Benz is quicker at getting future technologies to where it matters most: on the road. By the end of 2012, you will have more than 140 Mercedes-Benz models with BlueEFFICIENCY technologies at your disposal, all of which help you reduce your impact on the environment. Our BlueEFFICIENCY concept comprises innovations for efficient mobility as well as optimised processes all the way along the value chain.

The BlueEFFICIENCY measures – the Mercedes-Benz efficiency package. This package consists of comprehensive vehicle optimisations which ease the burden on the environment. Each model combines the most efficient engine with intelligent, latest-generation aerodynamic and energy-management measures. Such measures include the ECO start/stop function, which is being made available for an increasing number of models. The BlueDIRECT V6 and V8 petrol engines, which feature in several model series, deliver a much higher power output while reducing fuel consumption by up to 25%.

BlueTEC – the clean diesel. A modular emission-control system makes BlueTEC an exceptionally clean diesel technology. As well as removing 95% of the particulate, it also reduces nitrogen oxides by up to 90%. What remains is mainly water and nitrogen.

HYBRID – petrol and electric drives intelligently combined. Here the electric motor can be used both for accelerating and for recuperating braking energy, which is stored in the battery. What's more, the ECU shuts off the petrol engine when the speed is below 15 km/h. In this way, a HYBRID implements significant fuel savings.

BlueTEC HYBRID – clean diesel combined with electric drive. It marries the benefits of the HYBRID with those of BlueTEC: during braking, the kinetic energy is converted into electrical energy, which can be re-used when required. At the same time, the BlueTEC technology cleans the exhaust gases and removes many of the pollutants. All of which makes the economical diesel powerplant even more efficient and clean.

Innovative drive systems that break new ground: E-CELL and F-CELL. We have developed two locally emission-free drive systems which have been produced on a small scale since 2010. The B-Class F-CELL¹ uses hydrogen to produce power for the electric motor, while the A-Class E-CELL¹ draws its energy directly from two lithium-ion batteries.

But that is not all: under the banner “Design for Environment”, we also look at a vehicle's entire lifecycle and work hard to preserve the environment from the planning stage right through to recycling. In addition, we are involved in the development of alternative fuels and carry out research in the field of bionics. Further information about our comprehensive measures can be found at www.mercedes-benz.com/blueefficiency

¹ Provisional data: efficiency class: A++

The data are not based on an individual model and do not constitute part of the product offer; they are provided solely for purposes of comparison between different vehicle models

BlueEFFICIENCY in the SLK

The SLK has always been a vehicle that sets benchmarks. And the new SLK also lives up to these high technological standards where consumption and emission reduction are concerned



When we develop a new model, responsibility for the environment plays a crucial role. People's awareness is increasing as emissions, fuel consumption and fuel prices become topics that affect us all. It is therefore only natural that BlueEFFICIENCY measures are also implemented in the SLK models. And, far from being just a vision of a clean environment, BlueEFFICIENCY incorporates a whole raft of specific measures:

- 1 Aerodynamic exterior mirror housings
- 2 Tyres with optimised rolling resistance
- 3 ECO start/stop function
- 4 Refrigerant compressor only activated when actually needed
- 5 Intelligent alternator management
(alternator switched off in traction mode)
- 6 Ancillaries with energy-saving control and demand-dependent activity
(power-steering pump plus fuel and oil pump)
- 7 Current fuel consumption indicator
- 8 Gearshift recommendation for models with a manual transmission
- 9 Entire engine range meets all valid emissions standards
- 10 Engine technologies such as direct injection and turbocharging
- 11 Optimised aerodynamics through adjustable radiator shutter
(SLK 200 BlueEFFICIENCY, SLK 250 CDI BlueEFFICIENCY)

Petrol engines

Fun at the wheel and environmental compatibility can be brought down to a common denominator: with newly developed engine technologies that are impressively powerful but at the same time reduce fuel consumption and CO₂, as proven by the SLK's petrol engines

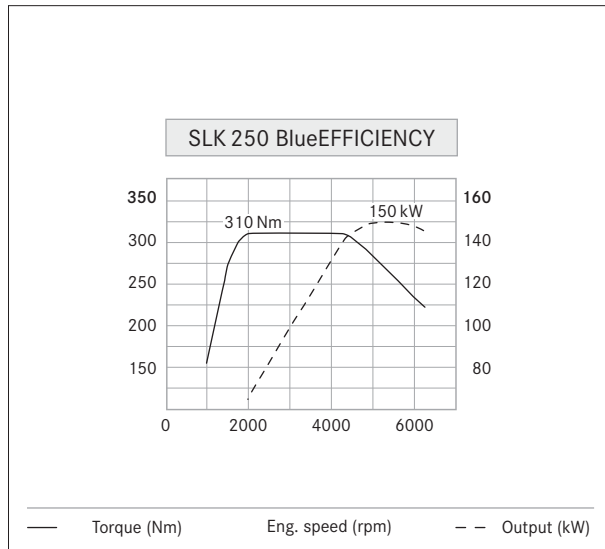

Delivering 150 kW of power, the SLK 250 BlueEFFICIENCY boasts dynamic performance

4-cylinder in-line engines. The optimised 4-cylinder unit with a displacement of 1.8 l, direct petrol injection, two overhead camshafts, variable valve control and turbo-charging delivers peak torque and output figures plus low consumption and emission values, in keeping with these environment-aware times. The direct petrol injection makes more efficient use of the fuel through virtually complete combustion. The variable valve control facilitates an optimum cylinder fill level and thus advantages where consumption is concerned. The latter are also achieved through the reduced weight and lower internal friction. Thanks to two balancer shafts the engines run with low vibrations in all engine speed ranges. What's more, the sound design makes for a pithy tone which pays acoustic homage to the automotive power.

The 4-cylinder petrol engine is available in two power categories: in the SLK 200 BlueEFFICIENCY with 135 kW and a maximum torque of 270 Nm and in the SLK 250 BlueEFFICIENCY with 150 kW and a maximum torque of 310 Nm.

Irrespective of the transmission variant chosen, both engines have the ECO start/stop function, which can help save fuel at traffic lights and in jams, easing the burden on the environment. And it goes without saying that the SLK meets the requirements of all the applicable emissions standards.

V6 engine. Over 20% less fuel consumption and lower CO₂ emissions compared to the predecessor model yet enhanced dynamism – a neat way of summing up the SLK 350 BlueEFFICIENCY. The new direct petrol injection uses spray-guided combustion and high-pressure injection by means of piezo injectors. Maximum output is 225 kW, while the peak torque of 370 Nm is available at 3500 rpm. Further factors that help to reduce fuel consumption include the standard-fit ECO start/stop function, a new air and exhaust system, controlled ancillaries, intelligent alternator management and systematically applied lightweight-design principles. The new 6-cylinder unit takes a vigorous approach coupled with outstanding refinement across the entire engine speed range, even low down. The backdrop to this comes courtesy of an impressive soundscape – of the calibre that only a six-cylinder can muster.



The SLK's petrol engines combine comfort and fun at the wheel with sustainability

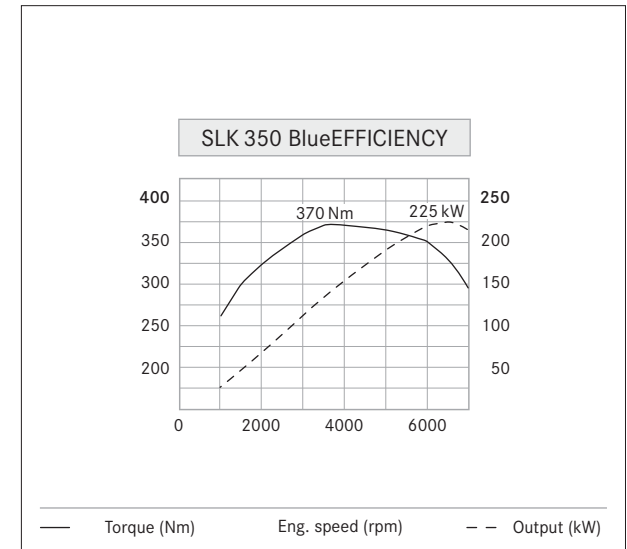

The SLK 350 BlueEFFICIENCY: cutting-edge engine technology with piezoelectric direct injection

Diesel engine

Unusual for a roadster – extraordinary for a diesel: the 4-cylinder in-line engine with an output of 150 kW and a torque of 500 Nm

4-cylinder in-line engine. Now the SLK also offers sporty driving enjoyment fuelled by diesel. Power and speed coupled with exceptionally low fuel consumption and emissions – these are the key attributes of the sophisticated 2.1-litre twin-turbocharged engine. Low fuel consumption and CO₂ emissions make the diesel SLK the most economical roadster in its segment. Yet it is still able to deliver sports-car-like performance: acceleration from 0 to 100 km/h takes just 6.7 seconds. Driving pleasure is further enhanced thanks to dynamic in-gear acceleration, as the engine serves up its impressive torque of 500 Nm at just 1600 rpm, giving the car unparalleled flexibility.

This level of performance is made possible by a whole host of innovative technologies. The fourth-generation common-rail diesel technology impresses on account of an increased injection pressure (2000 bar), optimised combustion chambers and highly precise injectors, while optimisation of the ignition pressure and charging means high torque across the entire engine speed range. The necessary refinement comes courtesy of two Lanchester balancer shafts. And optimised alternator management sees to it that the engine's coasting phases are used to great effect. So now it's possible to mention a sports car and a diesel engine in the same breath – without drawing startled glances.



The diesel unit developing 150 kW offers sporty performance and exceptional refinement with low fuel consumption and low CO₂ emissions

Transmissions

Whether it be a manual gearshift or an automatic, an economical or a sporty driving style – the transmissions for the SLK have been optimised in line with the engine with which they are installed. Plus they are intuitive and ergonomic to use

6-speed manual transmission. The SLK 200 BlueEFFICIENCY, SLK 250 BlueEFFICIENCY and SLK 250 CDI BlueEFFICIENCY¹ are paired with a 6-speed manual transmission as standard, offering impressively short and precise shift travel as well as optimum tuning of the gear ratios and rear axle ratio to the engine power. A display on the instrument cluster indicates recommended gear changes to further encourage a highly efficient driving style.

7G-TRONIC PLUS. The SLK 350 BlueEFFICIENCY is teamed up as standard with the optimised 7-speed automatic transmission 7G-TRONIC PLUS, which is available as an option for the SLK 200 BlueEFFICIENCY, SLK 250 BlueEFFICIENCY and SLK 250 CDI BlueEFFICIENCY. The 7G-TRONIC PLUS uses a new torque converter generation which stands for a more dynamic response, greater longevity, a further reduced noise level and significantly lower fuel consumption. The latter is also due in part to

the standard-specification combination with the ECO start/stop function, which ensures that the engine is temporarily switched off when standing at traffic lights or in a jam. In addition to this the 7G-TRONIC PLUS's seven forward gears facilitate an engine speed which is always ideally adapted, short shift travel and smooth gear shifting. At the same time motoring pleasure increases: the vehicle benefits from better acceleration and develops more pulling power. What's more, gears can be skipped for fast in-gear acceleration. Using a switch on the centre console, two transmission modes – "E" (Economy) and "S" (Sport) – can be preselected, and in conjunction with the optionally available steering-wheel gearshift paddles there is a third mode, "M" (Manual), for even faster gear shifting.

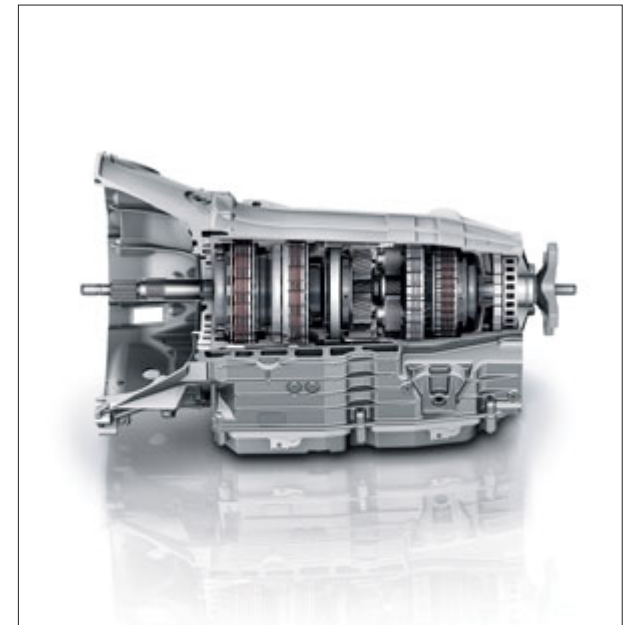

The 7G-TRONIC PLUS: one of over 18 million automatic transmissions produced in a period spanning more than 50 years

¹ Manual transmission for the SLK 250 CDI BlueEFFICIENCY available from the 2nd quarter of 2012

Chassis & suspension

With its sportily tuned suspension the SLK is already optimally prepared for a dynamic driving style – whilst remaining astonishingly comfortable. With the sports suspension or the Dynamic Handling package, fun at the wheel can be tangibly increased yet further through selectable suspension set-ups

Sports suspension (option, standard in conjunction with AMG Sports package). A sports suspension with tauter tuning and a body lowered by 10 mm is available as an option. Compared with the standard-specification suspension, the springs here are shortened, the dampers have a tauter design and torsion-bar stabilisers with a larger cross-section are fitted, which reduces rolling motion and increases driving stability.

Dynamic Handling package with Adaptive Damping System ADS (option). With the optionally available Dynamic Handling package a press of the sport button is all it takes to set the damper tuning to sports mode. The electronically controlled damper system varies its characteristics continuously and steplessly, optimally adapting the damping force at each individual wheel in

accordance with the current driving situation and road conditions. This results in greater driving stability in all speed ranges – and significantly more motoring pleasure. With the E/S push-button switch the 7G-TRONIC PLUS's shifting characteristic can be boosted separately: in the S program all the parameters are geared towards best-possible acceleration and a rapid reaction time.

Direct-Steer system (option, standard in conjunction with Dynamic Handling package). The Direct-Steer system is comprised of two components: firstly the speed-dependent regulation of the power steering control, familiar from the speed-sensitive steering. This requires significantly less steering effort when driving slowly, manoeuvring and parking. Secondly there is the rack and pinion with a variable ratio depending on the

steering angle, facilitating a more direct and more spontaneous implementation of the steering movements. This boosts agility and leads to a noticeable reduction in the steering input required in large steering angles, whilst the indirect ratio in the middle range supports consistent straight-line stability.

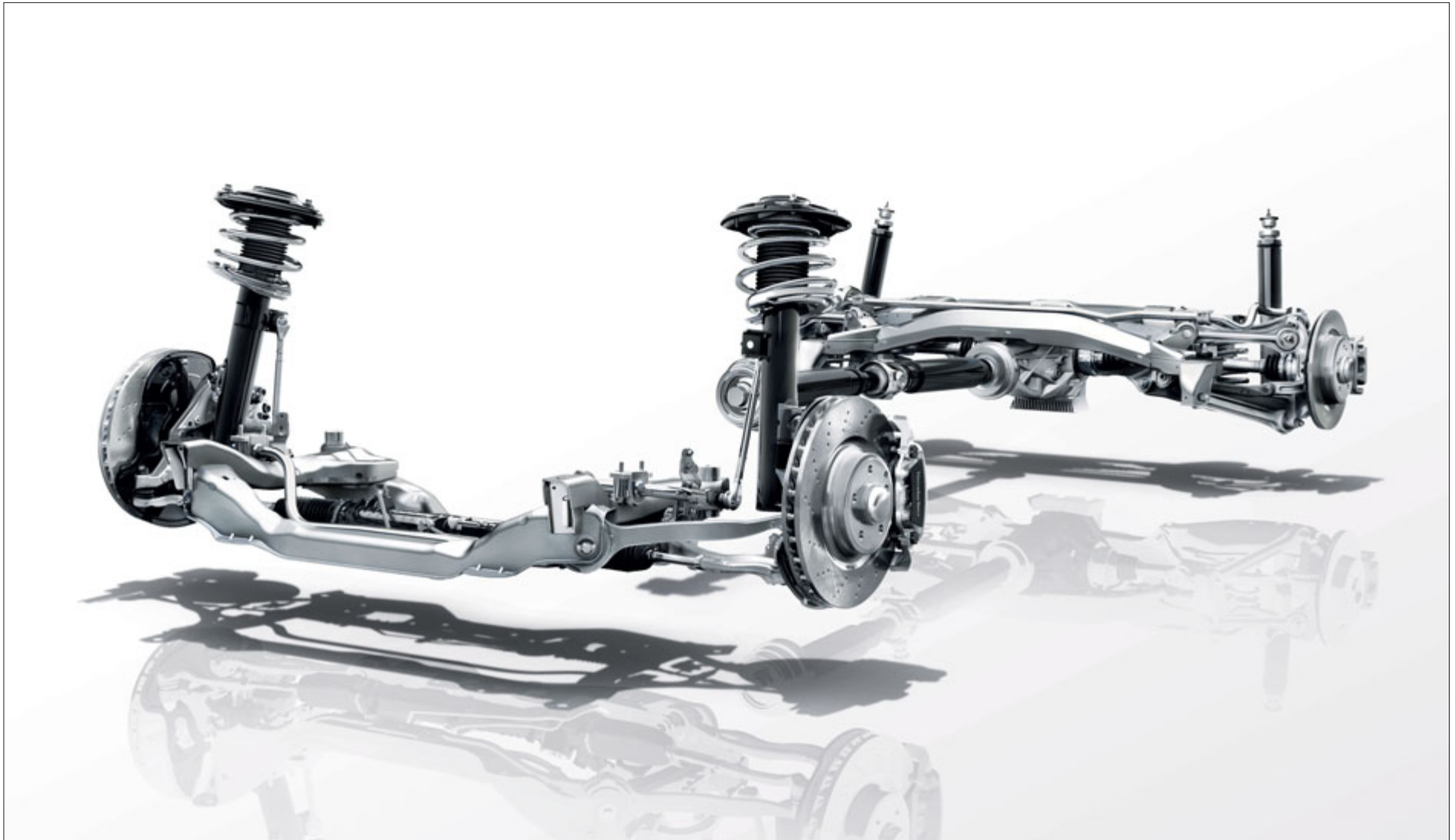

The Dynamic Handling package with Adaptive Damping System ADS: facilitates the ideal blend of sportiness and comfort

Safe driving

With the integral safety concept Mercedes-Benz pursues the vision of accident-free driving. Numerous measures can support the driver in critical situations, helping to prevent an accident

ATTENTION ASSIST (standard). This drowsiness detection system is especially useful on long trips. At speeds of between 80 and 180 km/h, ATTENTION ASSIST can warn the driver as soon as it detects signs of drowsiness or inattention. Several sensors analyse the driver's behaviour and can detect any changes compared with the driver profile individually determined previously.



If ATTENTION ASSIST detects signs of drowsiness, the system recommends a break

Intelligent Light System (option). The system has five settings: the country mode illuminates the edge of the road, the motorway mode the entire width of the road. The extended fog lamp function improves visibility, whilst the active light function and the cornering light function follow the driver's steering angle. Thanks to these functions, the best possible level of illumination is always at the driver's disposal, so that they can see the road's course, pedestrians or areas of danger earlier and better.



The Intelligent Light System automatically adapts to the prevailing weather, light and driving conditions

DISTRONIC PLUS (option). The DISTRONIC PLUS adaptive cruise control helps the driver to maintain the pre-selected distance between the car and the vehicle in front by braking the car, to a standstill if necessary, and then accelerating it again. The PRE-SAFE[®] Brake can initiate a full brake application around 0.6 seconds before an imminent collision to reduce the severity of the accident.

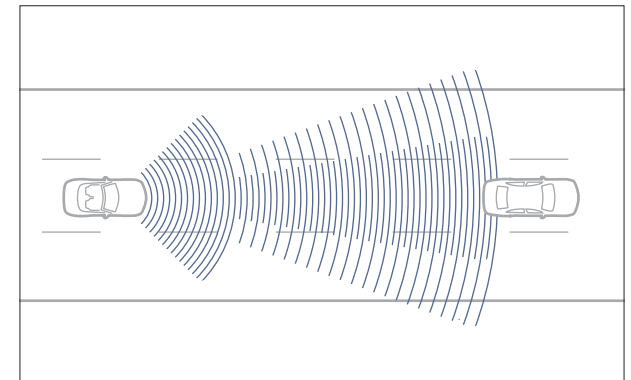

DISTRONIC PLUS supports drivers in automatically keeping their vehicle at a safe distance from the vehicle in front

ADAPTIVE BRAKE (standard). Together with the anti-lock braking system ABS and the Electronic Stability Program ESP®, the ADAPTIVE BRAKE system helps drivers to master critical braking manoeuvres. Thanks to the functions for dry braking in wet conditions and priming, the brakes respond even more directly. When starting on an incline, unintentional rolling back is prevented. If you press the brake pedal a second time, the HOLD function keeps the vehicle securely in its place.

Brake Assist BAS PLUS (option). Brake Assist BAS PLUS in conjunction with the PRE-SAFE® Brake can help to prevent rear-end collisions. The anticipatory system uses radar sensors to evaluate driving situations autonomously and, if needed, provides extra braking power based on the distance to the vehicle in front and the relative speed. If the radar sensors detect a potential collision and the driver applies the brakes in time, BAS PLUS is primed to apply braking pressure in accordance with the available stopping distance.



The adaptive brake lights contribute to perceptual safety by warning the traffic behind through flashing brake lamps as soon as the driver brakes heavily

In the event of danger and in an accident

The integral safety concept from Mercedes-Benz ensures highest possible levels of safety for the occupants – even in the event of danger or in an accident

Airbags (standard). Since October 1992 airbags have been part of the standard specification of all passenger cars from Mercedes-Benz. The SLK has a total of six standard-fit airbags which can, in conjunction with the seat belts, help prevent injury to the driver and passenger in the event of a collision: the front airbags which are deployed in two stages depending on the detected impact severity, plus sidebags in the seat backrests and headbags positioned in the door panel, which can reduce the stresses on the occupants during a side impact or if the car overturns.

NECK-PRO head restraints (standard). The crash-responsive NECK-PRO head restraints improve protection for the occupants and help to reduce the risk of whiplash injury. During a rear impact the head restraints are pushed forwards by around 40 millimetres and upwards by 30 millimetres, thus providing support for the heads of the occupants at an earlier stage.

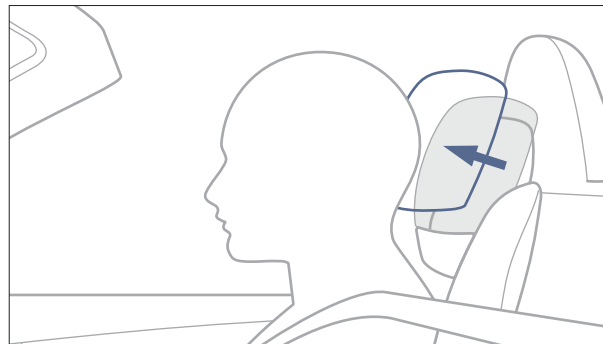

The NECK-PRO head restraints can reduce the risk of whiplash in a rear impact

Active bonnet (standard). The active bonnet can reduce the risk of injury to pedestrians or cyclists if they are involved in a collision with the bonnet in a speed range between 25 and 55 km/h. To cushion the blow, the bonnet is raised 8.5 centimetres at the rear by means of spring force.

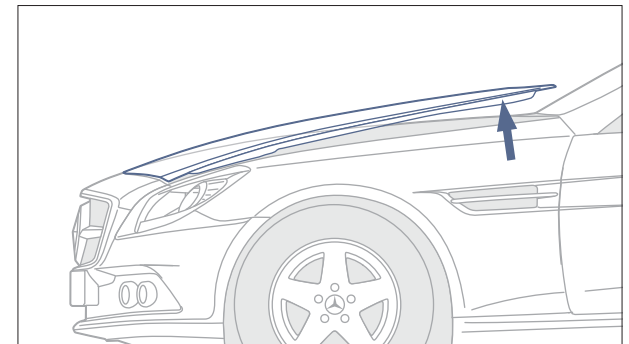

The active bonnet is part of the Mercedes-Benz protection system for weaker road users

PRE-SAFE® system (option). PRE-SAFE® can recognise critical driving situations in advance and if necessary activate safety systems by way of precaution, which can help to reduce the risk of injury for vehicle occupants. To accomplish this PRE-SAFE® continually monitors the sensor data from systems such as ESP® and BAS and can, for instance, identify events such as noticeable understeering or oversteering and emergency stops. If a critical driving situation is detected, the systems can respond within fractions of a second. The belt tensioners are activated (reversibly), the passenger seat is moved to a more favourable position (only in conjunction with Memory package) in the event of a collision and the side windows are automatically closed.

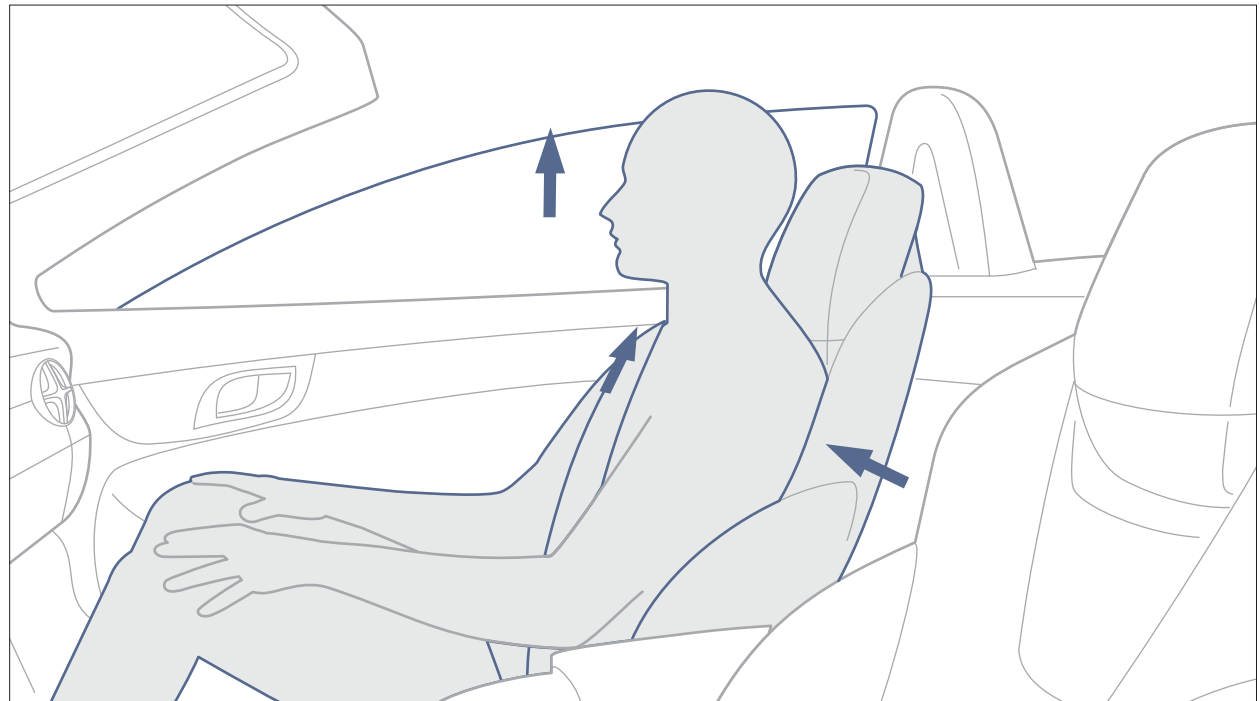

Multimedia systems

The highest levels of comfort take centre stage. Whilst the optional COMAND Online multimedia system entertains and navigates, all the elements can be easily controlled via the Controller, the multifunction steering wheel and the LINGUATRONIC voice-operated control system

Harman Kardon® Logic 7® surround sound system (option). Equipped with 10 loudspeakers and a 10-channel DSP sound amplifier, this optionally available sound system has an output of 500 watts, giving you first-class acoustics in both seats. 3D surround sound and speed-sensitive volume control ensure constant listening pleasure. In conjunction with COMAND Online, Dolby Digital 5.1 and DTS make for an exceptional audio experience.

COMAND Online (option). The multimedia system boasts a high-resolution 17.8 cm colour display. The system's functions include a radio, speed-sensitive volume control, the MUSIC REGISTER with a 10 GB hard disc and hard-disc navigation. What's more, for 3 years from the initial registration it also includes free updates for European map data. The best in entertainment comes courtesy of the DVD drive which plays CDs and MP3 files as well as video and audio DVDs. The online function facilitates access to the internet plus various mobile services from Mercedes-Benz via an internet-capable mobile phone.

A USB and an Aux-in socket, a slot for SD memory cards and a Bluetooth® interface enable connections to external data storage media and a mobile phone. The system is operated via the Controller and also via the buttons on the multifunction steering wheel. The LINGUATRONIC allows you to operate COMAND Online by voice entry.



The optional COMAND Online system includes a high-resolution 17.8 cm colour display which provides a clear overview of all the system functions.

Becker® MAP PILOT (option). The new Becker® MAP PILOT takes you safely to your destination and has everything you look for in a sophisticated navigation system. Fully integrated, it can be operated via the Controller and also the Audio 20 CD's display, plus it can be further individualised through the downloading of current map data and additional functions.



The Becker® MAP PILOT is fully integrated and can be operated via the Audio 20 CD

Assistance systems

There are numerous assistance systems to provide relaxation on the road. Their job is to support the driver when driving, but also when performing difficult manoeuvres

Speed Limit Assist (option, part of COMAND Online).

A windscreen-mounted camera that permanently scans the car's surroundings is able to recognise signed speed limits and indicate the detected maximum speed to the driver in the display. The driver can therefore check the prevailing speed limit at any time. This added convenience is of particular benefit on routes with variable speed limits or roadworks.



The information from the Speed Limit Assist is shown on both the instrument cluster and the COMAND Online central display

PARKTRONIC incl. Parking Guidance (option). The Parking Guidance can support the driver when parking and also when looking for a parking space: ultrasonic sensors at the side of the front bumper automatically measure the length of parking spaces at a speed of up to 30 km/h. If a suitable space has been found and reverse gear is engaged, the Parking Guidance starts. Via the instrument cluster it gives the driver visual and audible



Parking Guidance indicates suitable parking spaces to the driver and provides parking directions

instructions on the correct steering angle and the points at which to turn or reverse to park. The electronic parking aid PARKTRONIC monitors the front and rear of the vehicle when manoeuvring with the help of ten sensors and warns the driver if it detects a risk of collision. If the system identifies an obstruction, it emits a visual signal. As soon as the distance is less than approximately 35 cm, a short warning sound is emitted. If the vehicle gets even closer a continuous signal is heard. PARKTRONIC uses this procedure to make parking easier, even with limited space available. If the vehicle is not straight after reversing for the first time, the system also helps the driver with all further necessary manoeuvring.

Open-air comfort

Some of the SLK's features can make open-top motoring even more fun – at any time of year and in virtually any weather

AIRSCARF (option). The innovative neck-level heating developed by Mercedes-Benz extends the open-air season. At the touch of a button air is wrapped around the shoulders and neck of the driver and passenger like a warming scarf. In order to achieve this effect the system draws in cold air before warming it and releasing it again through discreetly positioned vents in the head restraints.

Sun-reflecting leather (standard in conjunction with leather, nappa leather and Exclusive nappa leather except designo leather). As an optional extra the SLK's seats are available with a coating which reflects heat. This prevents the seats from heating up in intense sunlight – bringing extra comfort, particularly when the vehicle is open.

AIRGUIDE (option). The innovative draught-stop system AIRGUIDE minimises draughts in the interior of the open vehicle. This involves the specially shaped, transparent plastic panels which are fixed to the roll-over bars swinging forwards between the head restraints – they are individually adjustable for the driver and passenger. The flow of wind is diverted and the turbulence that is usually experienced is largely prevented – even in the head area. This also increases comfort by significantly improving the aeroacoustics.



AIRSCARF has warm air aplenty to ensure perfect open-top motoring pleasure even in cool weather



The innovative draught-stop AIRGUIDE minimises draughts in the interior of the open vehicle

Roof and space

Comfort standards are redefined in the SLK. On the one hand, the innovative panoramic vario-roof with MAGIC SKY CONTROL creates an impression of space and airiness even in the closed vehicle. On the other, all the roof variants offer lots of room for luggage even when the car is open

Vario-roof (standard). With its magnesium/plastic lightweight design the vario-roof makes the SLK a weather-proof car for all seasons. At the touch of a button the vehicle is transformed from a coupé to an open roadster in less than 20 seconds – and vice versa. And even with the roof open you can still make good use of the boot.



The roadster's boot offers plenty of stowage space whether the roof is open or closed

Panoramic vario-roof (option). A panoramic vario-roof is available for the SLK as an optional extra. It lets a lot of light in, making the interior seem even lighter and roomier. The occupants can savour the pleasant atmosphere and that special open-top motoring feel even when the roof is closed.



Thanks to the panoramic vario-roof the occupants can enjoy an excellent view even when the roof is closed

Panoramic vario-roof with MAGIC SKY CONTROL (option). The SLK's innovative glass roof can change its light and energy transmission capability in seconds at the push of a button. In its transparent state it affords a view of the sky, even when the vehicle is closed. When darkened it protects against too intense sunlight.



MAGIC SKY CONTROL enables adjustment of the optional panoramic vario-roof's transparency

Climate control and light

A pleasant interior climate increases motoring pleasure and driver-fitness safety, so in the new SLK the temperature can be individually regulated and the interior stylishly showcased in darkness

Ambient lighting (option). The concept behind this showcasing of the car in the colour SOLAR red is to lend sporty emphasis to the interior design in darkness, alongside the direct illumination of the centre console and the armrests, and the indirect illumination of the door centre panel. As soon as the driver opens the door they are welcomed by the illuminated vehicle. After the door has been closed the light is automatically dimmed

– there are five possible brightness levels which can be set. As an option the ambient lighting can include the Interior Light package as an attractive addition.

Air conditioning (standard). This controls the temperature automatically for the driver and passenger. The specification includes air recirculation with an automatic window-closing feature, plus residual engine heat utilisation.

A combination filter (dust and activated charcoal filter) filters out particulate matter and improves the air quality.

THERMOTRONIC (option). The luxury automatic climate control THERMOTRONIC has separate temperature controls for each side of the interior, allowing the driver and passenger to travel in comfort at the temperature of their choice. At the touch of a button the 2-zone system works fully automatically. THERMOTRONIC keeps the desired temperature constant and also takes exterior factors such as sunlight, air quality and humidity into account via its sensors. This means that there is always a pleasant atmosphere in the SLK, boosting comfort on the one hand and the driver's concentration on the other, thus enhancing the safety of both occupants.



The optional ambient lighting gives the interior a particularly sporty aura

Seats

The sporty seats in the SLK meet the very latest requirements in terms of ergonomic design, comfort and safety

The SLK's sports seats offer excellent lateral support and tangibly stabilise the bodies of the driver and passenger – even at high speeds on winding roads. They also offer exceptional comfort on longer journeys. With their head restraints integrated in the backrests, the seats are both a safety element and a design feature. They emphasise the high quality of the vehicle design, forming a sporty, stylish focus – particularly when you look into

the open vehicle. In the base version in fabric the upholstery is entirely black. As an option it is possible to have your SLK fitted with seats in embossed leather in black, sahara beige or crystal grey or, alternatively, in nappa leather in black, bengal red or mocha/nut brown. With the Sports package the leather is also adorned with red topstitching and additional piping in the seat surface.

Memory function (option). Using the memory function you can save preferred settings for up to three different people. The seat and backrest position, steering wheel position and the exterior mirror position on the driver's and passenger's side can be stored and called up again at just the touch of a button.



The newly developed seats combine seating comfort with ergonomics, safety and sportiness

SLK 55 AMG exterior

Mercedes-Benz uses three letters to enhance sporty driving dynamics: AMG. With its immediately apparent combination of leading-edge technology, exclusivity and dynamism, the SLK 55 AMG promises a great deal. And it delivers in every respect – on every drive → www.mercedes-amg.com

The SLK 55 AMG – the epitome of a roadster with the heart of a top athlete. Evidence of the power harnessed by its new AMG engine is hinted at on the outside by the V8 lettering on the front wings. A small detail that marks the prelude to a wealth of AMG-specific design features.



The sporty rear end is drawn to a powerful conclusion by the AMG-design twin tailpipes and spoiler lip

The car is encased within the AMG front and rear aprons as well as the side sill panels, all of which exude a distinct feeling of power. Exclusively rounded off by a lower cross strut painted in high-gloss black, the simulated side air outlets at the front and the diffuser look at the rear. What's more, the radiator grille louvre



Exceptionally expressive: the 5-spoke AMG light-alloy wheels

painted in high-gloss black lends the SLK 55 AMG an even more powerful aura. So connoisseurs will be left in no doubt as to the car's AMG genealogy.

Further highlights include the AMG daytime running lamps as well as the darkened headlamps and tail lights. Plus the exhaust system features two chromed, oval twin tailpipes. So whichever way you look at it, the SLK 55 AMG is sure to make a lasting impression.

The car's appearance is further enhanced by 45.7 cm (18-inch) 5-spoke AMG light-alloy wheels painted titanium grey with a high-sheen finish, paired with 235/40 front and 255/35 rear tyres. What's more, optional extras from the AMG Performance Studio can transform the SLK 55 AMG into the AMG Mercedes of your dreams. With AMG, you too get to choose what high-performance sport looks like.



The AMG front apron, AMG light-alloy wheels and radiator grille louvre painted in black are clear indications that the car's sporty origins lie in Affalterbach

SLK 55 AMG interior

Few things can match the dynamism of the exterior. But the interior succeeds in doing so. By using high-quality materials to create luxury and, above all, sportiness à la AMG

Driving enjoyment begins the moment you sit down – one of the reasons why driving the SLK 55 AMG is such a pleasure. That's because the AMG sports seats offer optimum support when accelerating or negotiating twisting roads at speed. Control of the vehicle is assured by



Key data displayed at all times and full control of the car – thanks to the instrument cluster and the AMG performance steering wheel

the AMG performance steering wheel with aluminium shift paddles, which responds willingly to each steering input and conveys it straight to the Direct-Steer system. Road speed and rpm are monitored by the AMG instrument cluster, incl. RACETIMER, while the optional AMG-



The optional AMG analogue clock from IWC provides the perfect finishing touch in the sporty and luxurious interior

specific analogue clock in IWC design reminds you of the time, which you will more than likely be happy to forget when driving the SLK 55 AMG.

Precise craftsmanship, a desire for perfection and high-quality materials abound throughout the car's interior. So whoever takes their seat here is bound to feel ready for whatever adventures lie ahead. Having already been greeted by AMG door sill panels when opening the door.

Fine nappa leather in a choice of three colours is optionally available as an alternative to the standard ARTICO man-made leather/fabric appointments in black.



The luxurious interior boasts an exceptionally high-quality finish and has everything needed for sporty driving enjoyment

SLK 55 AMG technology

The heart of a sports car is its engine. In the SLK 55 AMG, the new AMG 5.5-litre V8 engine beats impressively in tune with the AMG SPEEDSHIFT PLUS 7G-TRONIC automatic transmission, offering an output of 310 kW, a torque of 540 Nm and the best fuel consumption figures in its segment

The SLK 55 AMG owes its outstanding driving dynamics to a host of willing helpers. The Direct-Steer system, for instance, makes for precise steering manoeuvres, while the Torque Vectoring Brakes allow controlled cornering at the critical limits. In this case, the inner rear wheel is braked specifically for a brief period, allowing the car to bank into the bend, thus enhancing both agility and active safety. The AMG sports suspension, equipped with AMG-specific springs, dampers and torsion bar,

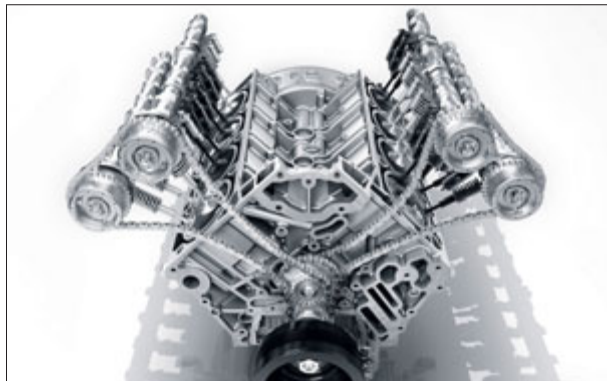

The AMG 5.5-litre V8 engine with AMG Cylinder Management boasts impressive performance figures and the lowest fuel consumption in its segment

also helps to achieve this effect. To tame the engine's incredible power, the SLK 55 AMG is fitted with the AMG high-performance braking system. The front brakes feature 4-piston fixed callipers with internally ventilated and perforated 360 x 36 mm discs for short stopping distances, while the rear brakes have 1-piston floating callipers with 330 x 22 mm discs. Because driving enjoyment is also about stopping at the right moment.



The engine developing max. 310 kW and 540 Nm provides outstanding forwards thrust, with the power being sent to the road with maximum effect via the AMG SPEEDSHIFT PLUS 7G-TRONIC

AMG 5.5-litre V8 engine. Its performance figures set the heart racing: 310 kW and a torque of 540 Nm available at even low engine speeds. Its fuel consumption, meanwhile, pays homage to reason – the 5.5-litre V8 unit is the most efficient high-performance engine in its segment. Thanks largely to the Controlled Efficiency stop/start function and the AMG Cylinder Management, which shuts off four cylinders when they are not needed. But one thing the AMG engine certainly doesn't reduce is the sonorous V8 engine note.

AMG SPEEDSHIFT PLUS 7G-TRONIC automatic transmission with double-declutching function. The AMG transmission sees to it that the engine power is sent to the road as effectively as possible. Gear changes are exceptionally rapid, while traction is practically uninterrupted. What's more, the double-declutching function allows even faster gear changes and prevents load-change reactions when braking into bends. With three modes to choose from – Sport, Comfort or Manual – driving pleasure is assured every time.

AMG Performance Studio

Although the SLK 55 AMG is already unique, it can be further individualised in the Performance Studio. Various equipment options can be selected to bring the sporty, expressive appearance and outstanding performance even further to the fore



The SLK 55 AMG can be further individualised in the AMG Performance Studio

A visit to the AMG Performance Studio represents the crowning glory for any AMG Mercedes. Various equipment options make the SLK 55 AMG an even sportier proposition, a case in point being the Handling package comprising compound front brake discs, performance suspension, a rear axle differential lock for optimum roadholding and the performance steering wheel trimmed with Alcantara® in the grip area.

Equally expressive are the 45.7 cm (18-inch) multi-spoke AMG light-alloy wheels – painted in either titanium grey with a high-sheen finish or matt black with a rim flange sporting a high-sheen finish. Those wishing to drive the car at up to 280 km/h won't want to miss out on the Driver's package, which includes a one-day driver training course.

Whatever you decide on, the AMG Performance Studio can meet almost any request.

Upholstery and trim

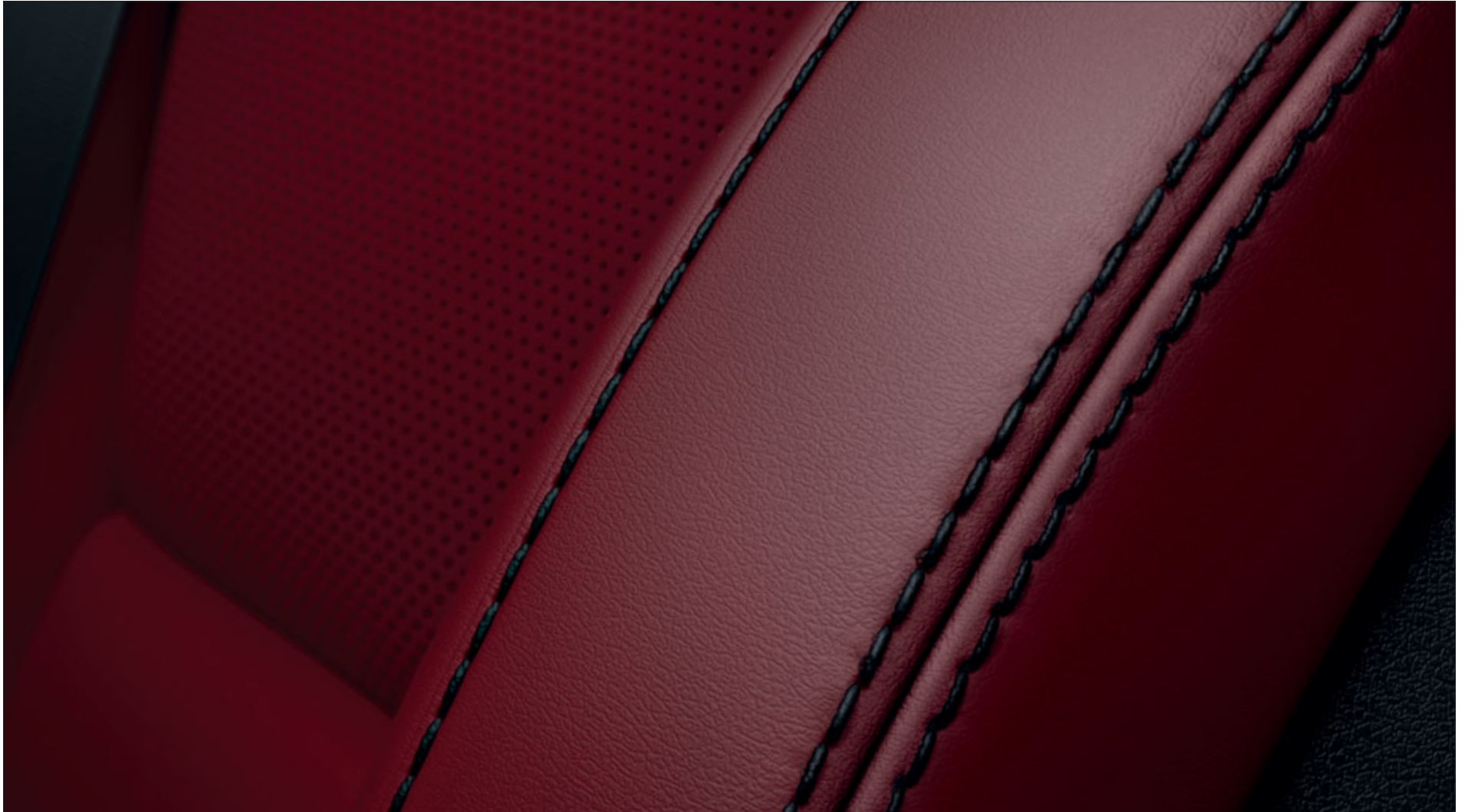



The black colour scheme sports black seats which are available either in fabric or, as an option, in leather, nappa leather or Exclusive nappa leather. The grey contrasting topstitching adds an eye-catching note. The centre console is in brushed aluminium as standard, while the metallic surfaces are in fine silver chrome.

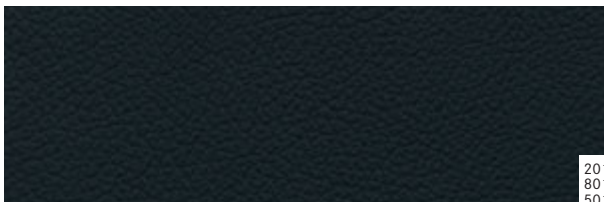
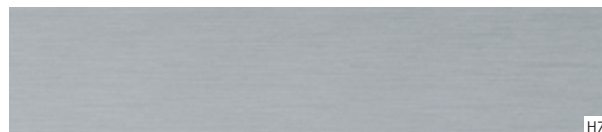

001

201
801
501

H76



736



731

BLACK

- 001 Fabric
 - 201 Leather
 - 801 Nappa leather
 - 501 Exclusive nappa leather
-

TRIM

- H76 Brushed aluminium
 - 736 High-gloss black ash wood (option)
 - 731 Dark brown burr walnut wood (option)
-



The crystal grey colour scheme sports crystal grey seats which are available in embossed leather. Black contrasting topstitching adds an eye-catching note. The centre console is in brushed aluminium as standard, while the metallic surfaces are in fine silver chrome.

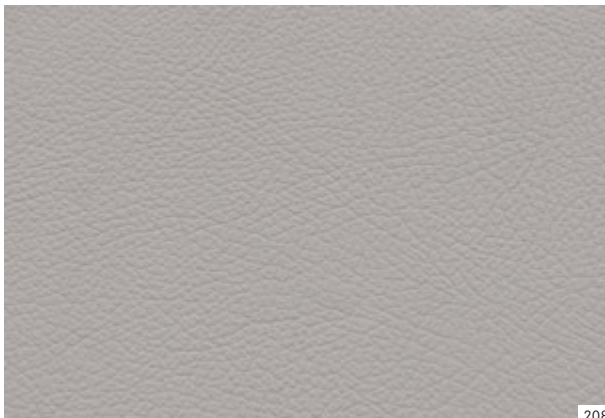

208

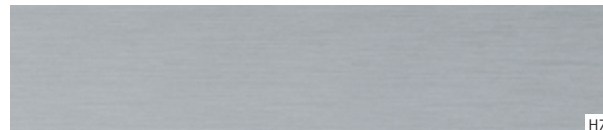

H76



736

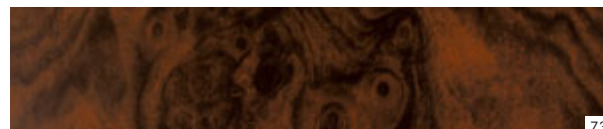

731

CRYSTAL GREY (option)

208 Leather

TRIM

H76 Brushed aluminium

736 High-gloss black ash wood (option)

731 Dark brown burr walnut wood (option)



The sahara beige colour scheme sports sahara beige seats which are available in embossed leather. Black contrasting topstitching adds an eye-catching note. The centre console is in brushed aluminium as standard, while the metallic surfaces are in fine silver chrome.

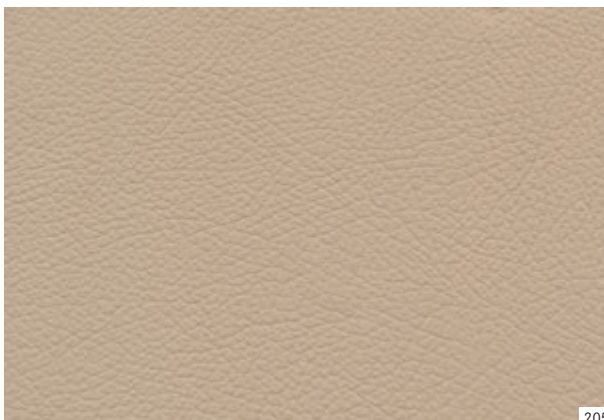

205

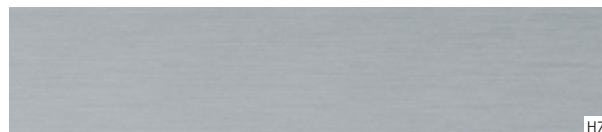

H76



736



731

SAHARA BEIGE (option)

205 Leather

TRIM

H76 Brushed aluminium

736 High-gloss black ash wood (option)

731 Dark brown burr walnut wood (option)



The bengal red colour scheme sports bengal red seats which are available in nappa leather or Exclusive nappa leather. Black contrasting topstitching adds an eye-catching note. The centre console is in brushed aluminium as standard, while the metallic surfaces are in fine silver chrome.

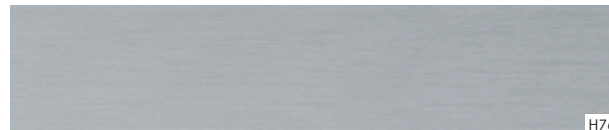

BENGAL RED (option)

807 Nappa leather

507 Exclusive nappa leather

TRIM

H76 Brushed aluminium

736 High-gloss black ash wood (option)

731 Dark brown burr walnut wood (option)



The nut brown colour scheme sports two-tone seats which are available in nappa leather or Exclusive nappa leather. The seat surfaces are in nut brown, the side bolsters in mocha brown. Saffron-coloured contrasting topstitching adds an eye-catching note. The centre console is in brushed aluminium as standard, while the metallic surfaces are in fine silver chrome.



854
554

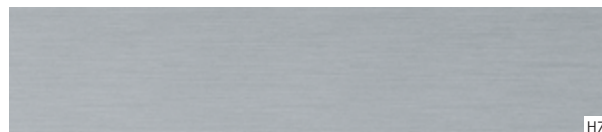

H76



736

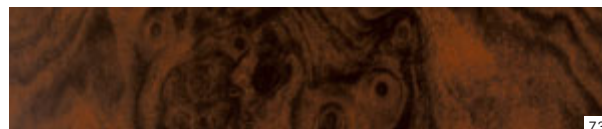

731

NUT BROWN (option)

854 Nappa leather

554 Exclusive nappa leather

TRIM

H76 Brushed aluminium

736 High-gloss black ash wood (option)

731 Dark brown burr walnut wood (option)

AMG Sports package

The SLK's sporty look is given the perfect finishing touch with the optional AMG Sports package

The optionally available AMG Sports package lends the SLK a dynamic look which starts on the exterior with the dynamic AMG front apron with LED daytime running lamps and the headlamps with dark edging, plus the



The distinctive rear apron – part of the AMG Sports package

powerful side sill panels. The theme continues with the striking rear apron and the dark-tinted tail lights. High-shine AMG light-alloy wheels with 225/40 R 18 front and 245/35 R 18 rear tyres complete the look.



5-spoke AMG light-alloy wheels with a high-shine finish

The sports suspension (including lowering by 10 mm) tangibly enhances lateral dynamics. For the 4-cylinder in-line models, the larger brakes with perforated discs and Mercedes-Benz lettering on the callipers ensure even more effective deceleration. For the SLK 200 BlueEFFICIENCY and SLK 250 BlueEFFICIENCY, a sportier engine sound provides the AMG Sports package's crowning glory.



The AMG Sports package offers exclusive sportiness for the SLK

AMG Sports package

Exclusivity meets sportiness in the SLK with the AMG Sports package



The perforated multifunction steering wheel with red topstitching



The instrument cluster with its "Chequered Flag" design

The AMG Sports package's interior concept also impresses with its sporty details. The instrument cluster with its "Chequered Flag" design adds to the dynamic feel, as does the steering wheel, which is a comfortable fit in your hands, in conjunction with 7G-TRONIC PLUS with shift paddles, with perforated leather and red topstitching. The red topstitching adorns the seats with their specific longitudinal piping, the armrests in the doors and centre console and the shift lever gaiter, adding characteristic touches, as do the red seat belts. In addition to all this, AMG floor mats are part of the package's exclusive specification.



Sportiness and dynamism abound in the interior of the SLK with the AMG Sports package



designo

The exclusive designo paintwork, leather appointments and trim stand for individuality → www.mercedes-benz.com/designo

Maximum individuality for the SLK comes courtesy of designo. The carefully selected materials are processed with unerring craftsmanship and precision to create an unmistakable masterpiece. The single- or two-tone designo leather appointments with the characteristic design for the seats and the door centre panels are available in a selection of 11 exclusive colour shades. Coordinating designo trim, high-gloss black piano lacquer or sporty AMG Carbon-Fibre offer a wealth of individualisation options.

The designo range for the interior is rounded off by the exclusive window frames in Alcantara® anthracite and in red or silver-coloured seat belts. The designo selection also includes five unique paintwork variants, two of which are matt finishes.



Sporty AMG carbon-fibre trim

Standard equipment | Selection



ATTENTION ASSIST



Electric parking brake



Clear-lens headlamps and daytime running lamps



Air conditioning



LED tail lights



Vario-roof



Audio 20 CD



Ergonomic sports seats



Multifunction steering wheel with a flattened bottom section



USB interface and Aux-in socket in the centre console



Door sill panel in stainless steel



Roof controls and Controller

Optional extras | Selection



Panoramic vario-roof with MAGIC SKY CONTROL



Becker® MAP PILOT for Audio 20 CD



Intelligent Light System with LED daytime running lamps



Ambient lighting



Exclusive Nappa Leather package



Harman Kardon® Logic 7® surround sound system



AIRGUIDE and roll-over bars with anodised aluminium insert



AIRSCARF neck-level heating



COMAND Online multimedia system



Electric seat adjustment with Memory function



KEYLESS-GO



Analogue clock

Wheels



10-spoke light-alloy wheels with 205/55 R 16 tyres (standard for SLK 200 BlueEFFICIENCY, Code 39R)



5-spoke light-alloy wheels with 205/55 R 16 front and 225/50 R 16 rear tyres (Code R19)



10-spoke light-alloy wheels with 225/45 R 17 front and 245/40 R 17 rear tyres (standard for SLK 350 BlueEFFICIENCY, Code R35)



Multi-spoke light-alloy wheels with 225/45 R 17 front and 245/40 R 17 rear tyres (option, Code R81)



9-spoke light-alloy wheels with 205/55 R 16 tyres¹; 205/55 R 16 front and 225/50 R 16 rear tyres (standard for SLK 250 CDI BlueEFFICIENCY, Code R49)



5-spoke light-alloy wheels with 225/45 R 17 front and 245/40 R 17 rear tyres (standard for SLK 250 BlueEFFICIENCY, Code 37R)



5-spoke light-alloy wheels with 225/40 R 18 front and 245/35 R 18 rear tyres (option, Code R32)

¹ No-cost option for SLK 200 BlueEFFICIENCY and SLK 250 BlueEFFICIENCY, Code R12 ² incenico light-alloy wheels are supplied without tyres



5-spoke AMG light-alloy wheels with a high-sheen finish, with 225/40 R 18 front and 245/35 R 18 rear tyres (AMG Sports package, Code 782)



Multi-spoke AMG light-alloy wheels, painted titanium grey with a high-sheen finish, with 235/40 R 18 front and 255/35 R 18 rear tyres (Code 796)



5-spoke AMG light-alloy wheels, painted black with high-sheen finish, with 225/40 R 18 front tyres and 245/35 R 18 rear tyres (genuine accessories)



10-spoke incenio light-alloy wheels², palladium silver with high-sheen finish, "bicolor", 225/45 R 17 front and 245/40 R 17 rear tyres (genuine accessories)



5-spoke AMG light-alloy wheels, painted titanium grey with a high-sheen finish, with 235/40 R 18 front and 255/35 R 18 rear tyres (Code 790)



Multi-spoke AMG light-alloy wheels, painted black, rim flange with high-sheen finish, with 235/40 R 18 front and 255/35 R 18 rear tyres (Code 760)



6-spoke incenio light-alloy wheels², in titanium silver, with 205/55 R 16 tyres (genuine accessories)



5-twin-spoke light-alloy wheels, in palladium silver with high-sheen finish, "bicolor", with 225/40 R 18 front and 245/35 R 18 rear tyres (ex-factory accessory wheels, Code 22R)



Distinctive MercedesSport rear spoiler and light-alloy wheels from the range of genuine accessories for the SLK

Genuine accessories

The Mercedes-Benz genuine accessories range offers everything you need to make the SLK even sportier: a whole host of accessory products optimally tailored to the vehicle

With the Mercedes-Benz genuine accessories range the character of your vehicle can be highlighted even more: with the MercedesSport rear spoiler, for instance, the chromed fin attachments for the bonnet or the light-alloy wheels in various designs and sizes.

There are also lots of useful, practical products to choose from, such as the shallow boot tub. With its slightly raised edge the shape of the tub is an ideal fit for the boot sill, and the load is better protected against slipping thanks to the tub's ribbed structure.

The genuine accessories range offers you a selection of high-quality, practical products.



Fin attachments for the bonnet, chromed

To find out more, please see our Accessories brochure or consult your authorised Mercedes-Benz dealer who will be pleased to advise you.



Load compartment tub, shallow

Services

MercedesCard. The card is your ticket to the Mercedes-Benz experience. Four times a year, we will send you the Mercedes-Benz Magazine, featuring fascinating reports from the world of Mercedes-Benz and articles about our latest vehicles. A MercedesCard also has many other uses too. As a VISA credit card, it is an internationally accepted means of payment. Further benefits are available to provide you with peace of mind, such as insurance packages for your Mercedes and other insurance services for the whole family. Further details can be found at www.mercedes-benz-bank.de¹

Mercedes-Benz Financial Services. Mercedes-Benz stands for quality, innovation and safety – and the same applies to Mercedes-Benz Financial Services. Our innovative leasing and financing products are tailored to your financial needs and means, making it easy for you to secure the keys to your dream car. Once you are on the road, our insurance products offer you comprehensive protection on every trip. Finally, our service products ensure that your car is always in tip-top condition whilst

keeping costs transparent and easily manageable. For a detailed quotation, please contact your Mercedes-Benz dealer, who will be glad to go through the latest financial services and terms and conditions with you.

Mercedes-Benz mobility. Your new car comes complete with the promise of feeling safe on the road, but if you should ever need assistance, then Mercedes-Benz Service24h is there to help. Just call the freephone service hotline on 00800 1 777 7777². The integrated telematics service, Mercedes-Benz Contact³, is even more customer friendly: a touch of a button is all it takes to contact the Mercedes-Benz customer centre. If you wish, the relevant vehicle and position-related data can be transmitted at the same time, thereby allowing the centre to react quickly and provide rapid on-the-spot assistance. Also standard with your new car at no extra charge is the Mercedes-Benz Mobilo⁴ mobility package. Whether you have lost your key, had a breakdown which cannot be repaired immediately or suffered damage to the vehicle due to an accident or vandalism, Mobilo is there to help you reach your destination – anywhere

in Europe. Whatever your problem, one thing is certain: you will soon be able to resume your journey.

Mercedes-Benz Museum. Experience 125 years of automotive history against an architecturally impressive backdrop. Over 1500 exhibits on nine levels give you an insight into the unique tradition and powers of innovation of the Mercedes-Benz brand in Stuttgart. See the world's first two automobiles in the shape of the Benz Patent-Motorwagen (motor car) and the Daimler motorised carriage – plus the automotive future of Mercedes-Benz – in an area covering a total of 16,500 square metres. We look forward to your visit – online, too, at www.mercedes-benz-classic.com/museum

Test drive. The unique feeling of driving a Mercedes cannot be put into words. Which is why we'd like to invite you to experience it for yourself. Take a test drive and find out first hand how it feels to drive your dream car. Simply visit www.mercedes-benz.com to locate your nearest Mercedes-Benz dealer.

¹ Information about the MercedesCard in Austria and Switzerland can be found on the Mercedes-Benz websites for these countries ² Alternative: +49 69 95 30 72 77. The only charge incurred is the cost of the mobile phone call to the landline network

Interactive Owner's Manual. The website also offers an interactive tour, enabling you to take a closer look at your desired model. Experience key functions in detail, gain an insight into the car's inner workings or look at the benefits of each model at www.mercedes-benz.de/owners-manual

Mobile internet. Now you can access the entire world of Mercedes-Benz from your mobile phone. As well as an overview of all the passenger car models, there are insights into the entire brand world along with a wealth of entertainment offers and direct links to our range of services at www.mercedes.mobi

Service packages. Vehicle-specific services allow you to put together an individual package for your Mercedes-Benz: for a small monthly premium the Excellent service package covers all service jobs including maintenance, wear and repairs – for up to five years. Simply present your service card and you will be safe from any financial surprises. And you can rely on the fact that your Mercedes-Benz will remain on top form for a

long time to come. With the Advance service package your Mercedes-Benz will stay at its best for longer still: you will be protected against unexpected repair costs even after the manufacturer's warranty or the service package has expired – for up to ten years.



Repair following an accident. Should the worst come to the worst, the Mercedes-Benz accident repair service provides you with the best help available for your vehicle, which will retain its valuable safety properties. From work on the paint to bodywork or glass damage – optimally trained specialists will repair your Mercedes-Benz at your Mercedes-Benz service partner, and you will soon be back on the road again. Further information is available from your authorised Mercedes-Benz dealer.



³ Requires a factory-fitted radio, connected to an operational mobile phone. The only charge incurred is the cost of the mobile phone call to the landline network ⁴ Once the warranty for breakdowns has expired (four years), Mobilo can be extended in periods of one year for a maximum of 30 years, provided that regular maintenance is carried out by your Mercedes-Benz service partner

Dimensions

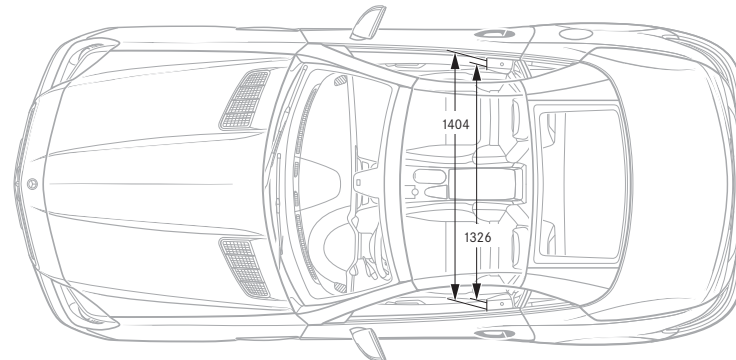
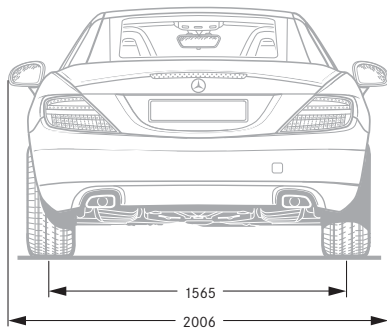
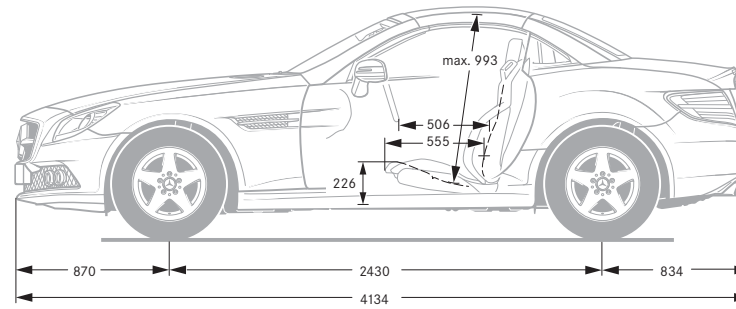
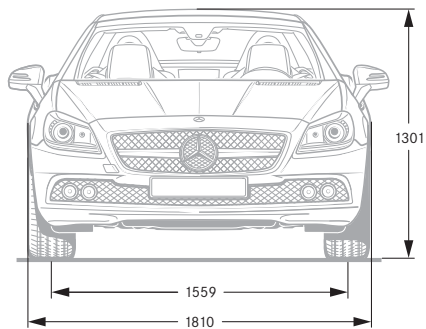

Paintwork

NON-METALLIC PAINTS (standard)

040 black

590 fire opal

650 calcite white

METALLIC PAINTS (option)

197 obsidian black

755 tenorite grey

775 iridium silver

792 palladium silver

794 pearl beige

799 diamond white BRIGHT

890 cavansite blue

963 indium grey

SPECIAL PAINTS (option)

967 galenite silver

- designo zircon red¹

Further individual paint finishes can be found in the designo range.

DIESEL ENGINE	SLK 250 CDI BlueEFFICIENCY⁵
No. of cylinders/arrangement	4/in-line
Total displacement (cc)	2143
Rated output ¹ (kW at rpm)	- (150/4200)
Acceleration from 0 to 100 km/h (s)	- (6.7)
Top speed, approx. (km/h)	- (243)
Fuel consumption ² (l/ 100 km)	
Urban	- (6.2-6.1)
Extra-urban	- (4.3-4.1)
Combined	- (5.0-4.9)
CO ₂ emissions ² (g/km) combined	- (132-128)
Efficiency class	- (A)
Emission class	Euro 5
Tank capacity (l)/incl. approx. reserve	60/8.0
Boot capacity (l)	
With the roof closed	335
With the roof open	225
Turning circle diameter (m)	10.52
Kerb weight ³ (kg)	- (1590)
Perm. GVW (kg)	- (1905)

NON-METALLIC PAINTS



METALLIC PAINTS

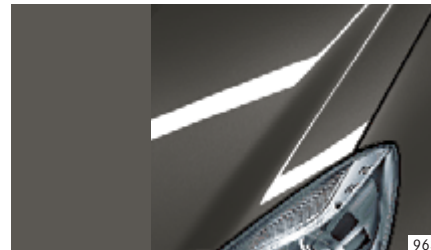
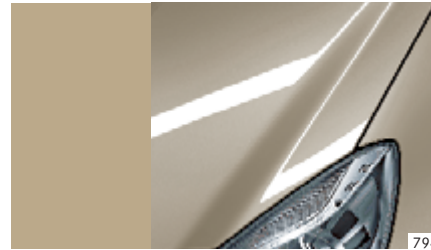
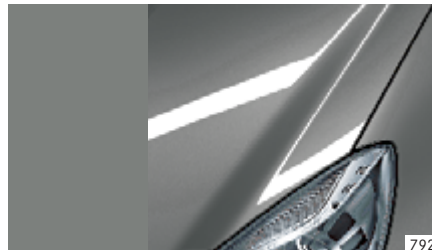
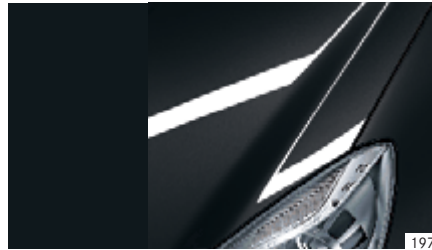

SPECIAL PAINTS

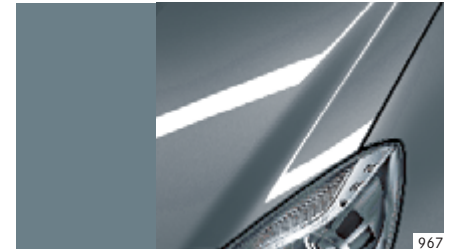

Technical data

PETROL ENGINES	SLK 200 BlueEFFICIENCY	SLK 250 BlueEFFICIENCY	SLK 350 BlueEFFICIENCY	SLK 55 AMG
No. of cylinders/arrangement	4/in-line	4/in-line	6/V	8/V
Total displacement (cc)	1796	1796	3498	5461
Rated output ¹ (kW at rpm)	135/5250	150/5500	225/6500	- (310/6800)
Acceleration from 0 to 100 km/h (s)	7.3 (7.0)	6.5 (6.6)	- (5.6)	- (4.6)
Top speed, approx. (km/h)	240 (237)	244 (243)	- (250) ⁴	- (250) ⁴
Fuel consumption ² (l/ 100 km)				
Urban	9.3-8.9 (8.6-8.3)	9.8-9.5 (8.7-8.4)	- (9.9)	- (12.0)
Extra-urban	5.3-5.0 (5.3-4.9)	5.8-5.3 (5.4-5.0)	- (5.5)	- (6.2)
Combined	6.8-6.4 (6.5-6.1)	7.3-6.9 (6.6-6.2)	- (7.1)	- (8.4)
CO ₂ emissions ² (g/km) combined	158-149 (151-142)	169-160 (153-144)	- (167)	- (195)
Efficiency class	C (C)	D (C)	- (D)	- (E)
Emission class	Euro 5	Euro 5	Euro 5	Euro 5
Tank capacity (l)/incl. approx. reserve	60/8.0	60/8.0	60/8.0	70/9.0
Boot capacity (l)				
With the roof closed	335	335	335	335
With the roof open	225	225	225	225
Turning circle diameter (m)	10.52	10.52	10.52	10.53
Kerb weight ³ (kg)	1435 (1470)	1475 (1500)	- (1540)	- (1610)
Perm. GVW (kg)	1750 (1785)	1790 (1815)	- (1855)	- (1910)

Figures in brackets refer to engines with an automatic transmission

¹ Figures in accordance with Directive 80/1269/EEC in the currently applicable version ² The figures shown were obtained in accordance with the prescribed measuring process (Directive 80/1268/EEC in the currently applicable version).

The figures are not based on an individual model and do not constitute part of the product offer; they are provided solely for purposes of comparison between different vehicle models

³ Figures in accordance with Directive 92/21/EC, version 95/48/EC (kerb weight with fuel tank 90% full, driver, 68 kg, and luggage, 7 kg) for standard-specification vehicles. Optional extras and accessories will generally increase this figure and reduce the payload capacity accordingly

⁴ Electronically governed ⁵ Manual transmission for the SLK 250 CDI BlueEFFICIENCY available from 2nd quarter of 2012. Further technical data can be found at www.mercedes-benz.com

Take-back of end-of-life vehicles. Coming full circle. At the end of its long life, you can return your SLK-Class to us for environment-friendly disposal in accordance with the EC End-Of-Life Vehicle Directive¹. But that day lies a long way off.

¹ Applies in accordance with national regulations to vehicles up to 3.5 tonnes gross weight. Mercedes-Benz passenger cars have met the statutory regulations governing the suitability of their design for reuse and recycling for a number of years now. A network of vehicle take-back depots and dismantlers has been established which will process your vehicle in an environment-friendly manner. The ways in which both vehicles and parts can be recovered are subject to ongoing development and improvement. Consequently, the SLK-Class will be able to comply with any future increases in the recycling quota within the stipulated time limits

Please note: changes may have been made to the product since this brochure went to press (22.07.2011). The manufacturer reserves the right to make changes to the design, form, colour and specification during the delivery period, provided these changes, while taking into account the interests of the vendor, can be deemed reasonable with respect to the purchaser. Where the vendor or the manufacturer uses symbols or numbers to describe an order or the subject of an order, no rights may be derived solely from these. The illustrations may show accessories and items of optional equipment which are not part of standard specification. Colours may differ slightly from those shown in the brochure, owing to the limitations of the printing process. This brochure is distributed internationally. It provides a general indication of the range of models, features, optional extras and/or colours available in various countries. Some of the models, features, optional extras and/or colours shown may not be available in your country or may only be available in a different specification. Additionally some models, features, optional extras and/or colours may only be available in combination with others. For current and more specific information in relation to the range of models, features, optional extras and/or colours available in your country, and their pricing, you should contact your nearest authorised Mercedes-Benz Passenger Car Dealer. www.mercedes-benz.com