

This Brochure is prepared by Daimler AG and it predominantly reflects the capabilities and performance of vehicles sold in Europe. Some characteristics, capabilities, performance features and optional extras (e.g. towing systems) may not be available or may not apply in Australia or under Australian conditions. The information in this Brochure is therefore indicative, illustrative and provided only for guidance and should not be relied on. To obtain current and accurate information on a vehicle and any options applicable to Australia, contact your local authorised Mercedes-Benz dealer.



Mercedes-Benz



## The SLS AMG Coupé and Roadster

**AMG**



Mercedes-Benz



with the highest levels of rigidity, a front mid-engine with a drive system featuring a  
highest calibre. **SLS AMG Coupé**. You will just seize any opportunity you possibly can  
ive ideas on loan from aircraft construction add some thrilling touches. They show that  
more than confirmed whilst driving – because beneath the auspicious exterior lies sheer  
ng car – only with a cup holder and automatic climate control. The AMG high-performance  
uperb driving dynamics. And a distinct feeling of butterflies – over and over again. Anyone  
in the SLS AMG shifts in less than 100 milliseconds – without any interruption to the  
your destination – or out of sight – faster. The finest hand-sewn nappa leather. Solid metal  
e the handcrafted character of the SLS AMG. Rarely did a super sports car come up with  
oes, too: AMG sports seats with perfect lateral support and high long-distance comfort  
scent of the thrust lever in a jet. “It’s a car”, says the voice of reason. “It’s a jet” reply  
are reminiscent of those in an aircraft’s cockpit, and the passenger cell is like a well-fi

transaxle configuration for optimum weight distribution and a sophisticated high-tech  
n to be out on the road in it. These doors hold the keys to hearts that beat faster when  
at even at a standstill it would be a massive understatement to describe the SLS AMG s  
er motor-racing technology. Exhilarating, powerful, breathtaking. In the SLS AMG Cou  
nance engine ensures impressive traction, the aluminium space frame low weight with  
who'd been hoping to take a break during shift delays had better think again. The AM  
e power delivery. Acceleration like this calls for a rear aerofoil that ensures sufficient c  
etal or optional genuine carbon fibre. Everywhere in the cockpit the driver sees and fe  
th so few reasons to get out. It's not just the engine output that gives the driver the fe  
t, an AMG performance steering wheel and in the centre console the AMG DRIVE UNIT  
y the emotions. **SLS AMG Roadster.** The SLS AMG places its driver low and breathtak  
tting helmet. All in all: a unique driving feel. Impressive on paper, overwhelming on t



## The stuff that dreams are made of: black-and-white chequer

Right from the outset the Mercedes-Benz brand has stood for sporting successes as well as comfort and luxury. Cars bearing the three-pointed star have always proven their performance over and over again – on the road and on the race track. The year is 1900. The first vehicle to go by the name “Mercedes” is delivered. It is the first modern-day car. It has an output of 35 hp. And it is a racing car. In 1952 the 300 SL, the legendary gull-wing model, first saw the light of day – and as the victorious winner it saw the chequered flags at the 24 Hours in Le Mans, the Berne Grand Prix and the Carrera Panamericana – in spectacular fashion. In 1967 the AMG sports car manufactory was founded, and in 1971 it caused a

sensation. At the 24 Hours in Spa, the legendary bright-red 300 SEL 6.8 AMG sped over the finishing line as the champion of its class – and into the history books. Countless victories in various different racing series followed – above all in the DTM. For some years now the engineers at Mercedes-AMG and Mercedes-Benz have been joining forces to develop the super sports car of modern times. They are striving for the maximum possible – with the same passion as their predecessors but using the technology of the future. The SLS AMG sees the black-and-white flag fall. The finishing line has been reached. A new legend is born.



# Can excitement be divided up into chapters? Let's see

## The models presented:

SLS AMG Coupé | AMG alubeam silver | Cover and from page 6 | 5-twin-spoke AMG light-alloy wheels, designo black Exclusive leather, AMG carbon trim

SLS AMG Coupé | AMG Le Mans red | From page 14 | 5-twin-spoke AMG light-alloy wheels, designo black Exclusive leather, AMG carbon trim

SLS AMG Roadster | AMG Sepang brown | Cover and from page 26 | 10-spoke AMG forged wheels, designo beige/black Exclusive leather, AMG Interior Carbon-Fibre package

SLS AMG Roadster | AMG alubeam silver | From page 52 | 10-spoke AMG forged wheels, designo beige/black Exclusive leather, AMG Interior Carbon-Fibre package

---

The illustrations may show accessories and items of optional equipment which are not part of standard specification.





## Fascination

06 SLS AMG Coupé

26 SLS AMG Roadster

## Facts

52 AMG

56 Drive system

62 Chassis & suspension

68 Equipment & appointments

94 Services

96 Facts & figures

A dramatic landscape featuring a stone wall in the foreground, with a car's wing visible in the top right corner. The background shows a vast, hazy landscape under a cloudy sky.

## A cockpit. An engine. Two wings. Is it still a car?

These doors hold the keys to hearts that beat faster when it comes to pure automotive design. Creative ideas from aircraft construction add some thrilling touches. They show that even at a standstill it would be a huge understatement to describe the SLS AMG Coupé simply as a “car”. An impression that is more than confirmed whilst driving – for beneath the auspicious exterior lies sheer motor-racing technology.

SLS AMG / 6.7





SLS



AMG

D SLS 6397

It, too, has ejector seats.  
But they catapult the driver forwards, not upwards

Exhilarating, powerful, breathtaking. In the SLS AMG Coupé you feel as though you're driving a racing car – only with a cup holder and automatic climate control. The AMG high-performance engine ensures impressive traction, the aluminium

space frame low weight with the highest possible rigidity. The result: superb driving dynamics. And a distinct feeling of butterflies – over and again.



## Every paparazzo's nightmare

Anyone who'd been hoping to take a break during shift delays had better think again. The AMG SPEEDSHIFT dual clutch transmission in the SLS AMG shifts in less than 100 milliseconds – without any interruption to the power delivery. Acceleration like this calls for a rear aerofoil that ensures sufficient downforce. Helping you to get to your destination – or out of sight – faster.







You wouldn't mind being given "life"  
in this passenger cell

The finest hand-sewn nappa leather. Solid metal or optional genuine carbon fibre. Everywhere in the cockpit the driver sees and feels materials that underline the handcrafted character of the SLS AMG. Rarely did a super sports car come up with so few reasons to get out.

The image shows the interior of a Mercedes-AMG car. The focus is on the driver's side, featuring black leather seats with white stitching and an AMG logo on the seat. The center console has a gear shifter and handbrake. The steering wheel is also visible, and the overall interior is dark with metallic accents. The text is overlaid on the lower left portion of the image.

## The only thing that distinguishes it from a jet: the undercarriage stays out

It's not just the engine output that gives the driver the feeling of sitting in a jet – the interior does, too: AMG sports seats with superb lateral support and high long-distance comfort, an AMG performance steering wheel and in the centre console the AMG DRIVE UNIT with the E-SELECT selector lever, reminiscent of the thrust lever in a jet.





## Its cruising altitude? 369 mm above the tarmac

“It’s a car”, says the voice of reason. “It’s a jet” reply the emotions. The SLS AMG places its driver low and breathtakingly close to the tarmac. The instruments are reminiscent of those in an aircraft’s cockpit, and the passenger cell is like a well-fitting helmet. All in all: a unique driving feel.



The image shows the rear of a red Mercedes-Benz SLS AMG sports car on a dark asphalt road. The car is positioned on the right side of the frame, with its rear end facing the viewer. The license plate is 'SLS 6363'. The background is a vast, open landscape under a dramatic, cloudy sky with a bright light source breaking through the clouds, creating a hazy, atmospheric effect. The overall mood is one of power and elegance.

## Two wings make it an icon. The third prevents it from taking off

Even as the unique gullwing doors close above you, you can sense that you are about to become part of a legend. That this legend also sets new standards when it comes to performance and driving dynamics becomes clear at just 120 km/h. This is when the rear aerofoil is extended – for optimum rear downforce at high speeds and on swiftly taken bends. Of course it also puts in an appearance at the touch of a button – showing even at a standstill what the SLS AMG is made for.



A red Mercedes-AMG SLS is shown from a front-quarter perspective, driving on a road that stretches into the distance. The car is positioned on the right side of the frame, with its front grille, headlights, and license plate clearly visible. The license plate reads 'SLS 6363'. The background is a vast, dramatic sky filled with large, white, billowing clouds, suggesting a high-altitude or aerial setting. The overall mood is one of speed and luxury.

## The Red Baron for the road

The colour red represents energy, joy and passion. Now that the SLS AMG is on the scene, so do another eight colours. These include exclusive matt paints manufactured using technology that is as innovative as it is sophisticated: designo magno allanite grey and AMG Monza grey magno. And a completely newly developed colour shade that is reminiscent of liquid silver: AMG alubeam silver. The pilot – or the driver – can also choose from eleven carefully coordinated schemes for the interior appointments.







## Like being in free fall. Only horizontally

Impressive on paper, overwhelming on tarmac. Beavering away in the SLS AMG is the world's most powerful standard-specification naturally aspirated V8 engine – a promise that this super sports car is only too happy to keep, as soon as you so much as tap the accelerator.

And it delivers yet more: together with the AMG SPEEDSHIFT dual clutch transmission with its Race Start function the AMG 6.3-litre V8 front mid-engine equals exceptional performance. In other words: only the driver's pulse is faster.





## A spectacle of nature. Unleashed by our engineers

Raging storms prove to man how powerless he is in the face of nature and how such forces know no bounds. But it is also in the nature of mankind to research precisely these limits, to push them and compete against them. The Mercedes-AMG engineers have succeeded in building an engine whose power does not shy away from comparison with that of the strongest forces of nature; if the SLS AMG were

just a few km/h faster, this would correspond to the highest level on the scale used in the USA to classify whirlwinds. The SLS AMG has gone head to head with the standards used to record the most awe-inspiring natural phenomena anywhere in the world – until there are virtually no more limits left to push. High time for the Mercedes-AMG developers to start looking for a new role model.





## Having nothing and no-one above you has always been a privilege

The SLS AMG Roadster unmistakably has the genes of the SLS AMG Coupé, but its character is very much its own. It's a super sports car for which the sky's the limit – and not just when you're driving it with the top down.



## At last we can accurately talk of air travel

The SLS AMG Roadster blends breathtaking performance with superb driving dynamics – and its driver can feel this in no uncertain terms. In this cockpit the dream of flying even comes true on the road.









## Like thunder and lightning. And there's not a cloud in sight

Cause a storm when there's not even the slightest breeze – with this high-performance roadster, equipped with lots of technologies from motorsport. And don't forget to enjoy the odd sprint now and then, so that all this untamed force can be let loose.



## The solar system has a new centre

All eyes are on nothing but the roadster when it's on the road. The extremely flat and broad body and the striking, elongated lines indicate its enormous forwards thrust even at a standstill. An initial impression which is surpassed during the first few metres of the journey.





Let the sunshine in.  
It's been looking forward to this for 4.5 billion years

You are met by the finest materials in the SLS AMG Roadster: solid metal, fine nappa leather – and genuine carbon fibre as an option. You can experience all this in the light of the sun at the touch of a button – with a soft top that opens at record speed, as befitting this vehicle.







## The Entertainment package is fitted as standard. Under the bonnet

The engine sound of the AMG high-performance unit alone is an unparalleled listening experience. Those who can take even more bass can opt for the Bang & Olufsen BeoSound AMG sound system: music to your ears – even during open-top motoring.

A Mercedes-AMG SL convertible is shown from a front-quarter perspective, driving on a wet road during a heavy rainstorm. The car's headlights are on, and the license plate reads 'S LS 6308'. The background is a blurred, golden-hued landscape, possibly a beach or a wide road, with rain streaks visible in the air.

## A few raindrops like these can't dilute the adrenaline

The roadster always ensures an all-time high for the driver when it comes to roadholding and acceleration data – no matter what the weather forecast says. The route is irrelevant here, too – thanks to helpers such as the optional AMG RIDE CONTROL sports suspension with its adaptive damping system. It adapts perfectly to the requirements of both the driver and the road surface.





## A second can accommodate more happiness than you might think

Since its invention the car has been a symbol of freedom. But never before has the feeling of freedom been as intense an experience as it is in this roadster. The clouds fly past above you, the scenery alongside you and the kilometres on the speedometer. How wonderful that you can call up these blissful moments over and again.





S-LS 6308



## Just popping out for a breath of fresh air

The aluminium space frame for a lower weight coupled with high rigidity, a front mid-engine with a drive system featuring a transaxle configuration for optimum weight distribution and a sophisticated high-tech chassis – all this ensures handling of the highest calibre. You will just seize any opportunity you possibly can to be out on the road in it.



## Seldom has a lasting value been so dynamic

Built for tenths of seconds. And for eternity. The design of the SLS AMG Roadster is timeless. The long bonnet and the seats – positioned extremely far back – are particularly succinctly styled. The vehicle's overwhelming performance sees to it that the masterpiece is not merely visual.







## The technical explanation for dilated pupils

Over 5800 individual parts, distributed over a length of precisely 464 centimetres and a width of 194 centimetres, covered with up to 16.1 litres of paint. What do these figures have to do with dilated pupils? Normally the pupil dilates in darkness, so that more light can fall on the retina – this is the only way the eye can take everything in. This is simply the body’s way of reacting to a physical variable. But a dilated pupil can also be an emotional reaction, as scientists discovered in the 1970s: as soon as we are deeply moved and emotionally charged by something,

our brain – or, to be more precise, the limbic system – sends signals to the eye, and the pupil widens. And that’s how come a future driver will have the designers’ work to thank for the first physical reactions the vehicle provokes – even before they have had a chance to experience the acceleration and centrifugal forces. When the gullwing doors then fold out or the soft top opens up, the pupils become even bigger – a sign that the body is saying: “Give me more! I want to see every last detail.”





upholstery and trim. In an accident. Metallic paints. Sound system. Petrol engines. AMG  
ension. Optional extra. Fuel consumption. Interior. In the event of danger. LED daytime  
ESP<sup>®</sup>. Dimensions. Standard equipment. Light. Multimedia systems. Drive system. Gen  
ckage. Transmission. Surround sound system. Wheels. Interior. Safe driving. CO<sub>2</sub> emis  
nd trim. Assistance systems. BlueEFFICIENCY. In an accident. Metallic paints. Petrol e  
s. Top speed. Chassis & suspension. Optional extra. Fuel consumption. Interior. Airbag  
ts and colours. Climate control. Seats. ESP<sup>®</sup>. Dimensions. Standard equipment. Light.  
O<sub>2</sub> emissions. Memory package. Transmission. Surround sound system. Wheels. Interior  
ical data. Interior. Services. Safety. Assistance systems. Upholstery and trim. In an acc  
Safe driving. Light-alloy wheels. Top speed. Optional extra. Chassis & suspension. Fuel  
Engines. AMG. **The facts.** Paintwork. Total displacement. Climate control. Seats. Dimer  
ents. Light-alloy wheels. Memory package. Transmission. Surround sound system. Wh

We're now moving from the emotional to the technical section.  
But you won't notice the difference





## **AMG**

- 52 History
- 54 Philosophy

## **Drive system**

- 56 Vehicle concept
- 58 AMG 6.3-litre V8 front mid-engine
- 60 AMG SPEEDSHIFT DCT 7-speed sports transmission

## **Chassis & suspension**

- 62 AMG sports suspension
- 64 Aluminium spaceframe body
- 66 Gullwing doors

## **Equipment & appointments**

- 68 Safety features
- 70 Light-alloy wheels
- 73 AMG ceramic high-performance compound brakes
- 74 AMG Performance Media
- 76 Electric fabric top
- 80 Paintwork
- 82 Interior equipment and appointments
- 86 Standard equipment
- 88 Optional extras
- 90 Multimedia and navigation systems
- 91 Bang & Olufsen BeoSound AMG sound system
- 92 AMG Performance Studio

## **Services**

- 94 Mercedes-Benz Service

## **Facts & figures**

- 96 Dimensions and technical data





## 42 years of AMG in two minutes. Our customers like life in the fast lane

High speeds are AMG's special passion. So here are the most important facts about the company – in fast-forward mode. AMG was founded in 1967 as a Swabian two-man engineering firm that built racing engines. The breakthrough came a mere four years later with the class victory at the Spa 24 Hours race in 1971. In 1976 the company moved to its current headquarters in Affalterbach near Ludwigsburg. Since 2005 AMG has been a wholly owned subsidiary of Daimler AG;

today it employs nearly a thousand people and as Mercedes-AMG it is the performance brand of Mercedes-Benz Cars. Mercedes-AMG develops exclusive high-performance models including one-offs which are manufactured in accordance with individual customer requirements. The customers' powers of imagination are what drives the company in its relentless aim to be better and better and continue implementing new, exciting projects.



## The Mona Lisa wasn't painted by five masters either

An engine that is created at Mercedes-AMG is the product of many clever people's work. And the work of one clever person who is very good with their hands, to be precise. According to the "one man – one engine" principle, one single Mercedes-AMG technician assembles one single engine from start to finish. They are solely

responsible for all the individual work steps – from installing the crankshaft and the wiring to pouring in the engine oil. They meticulously implement the Mercedes-Benz quality criteria. And confirm this with their signature on the engine badge. Just like any true master signs a great work of art.



Handcrafted  
by

*Robert Feller*

Mercedes-AMG  
Affalterbach, Germany



## We made an exception with this car and paid our engineers to daydream

When do any engineers normally get the chance to live out their automotive fantasies without any restrictions? When they started work the Mercedes-AMG developers sat down with that famous blank sheet of paper yet ended up taking advantage of this unique opportunity in a record time of just 37 months. The result: a revolutionary super sports car whose every detail has been designed with driving dynamics in mind – whether it's a coupé or a roadster. The high-performance AMG engine, just 205 kg when dry, was installed as a front mid-engine – and sits

as low as possible in the vehicle. The drive system with a transaxle configuration helps achieve near-perfect weight distribution between the front and rear axle. And the body was constructed around these key components – as an ultra-light yet extraordinarily rigid structure whose gross weight has been significantly reduced thanks to intelligent optimisation. Pure driving dynamics – better than our engineers could ever have imagined in their wildest dreams.



## Dry sump lubrication. It's our favourite turn of phrase in the entire brochure

The SLS AMG's design engineers were able to position the engine as low as possible behind the front axle by changing over to an unusual type of lubrication technology: this was the only way they could do without the sump that is usually located beneath the engine. In its place an external oil tank and several pumps supply the engine with lubricant – even during high lateral acceleration. We could fill pages and pages writing about the other performance-enhancing measures that were implemented, so here are the most important ones in a nutshell: a newly

developed magnesium intake manifold with precisely matched resonance tube lengths for optimum cylinder flow, the use of exhaust headers, significantly lighter forged pistons plus the bucket tappets for a rigid valve train that improves power and torque output. The rest is written all over the faces of euphoric drivers: 6.3-litre V8, 420 kW, 650 Nm torque, acceleration from 0 to 100 km/h in 3.8 seconds, top speed 317 km/h. Figures can be such fun!

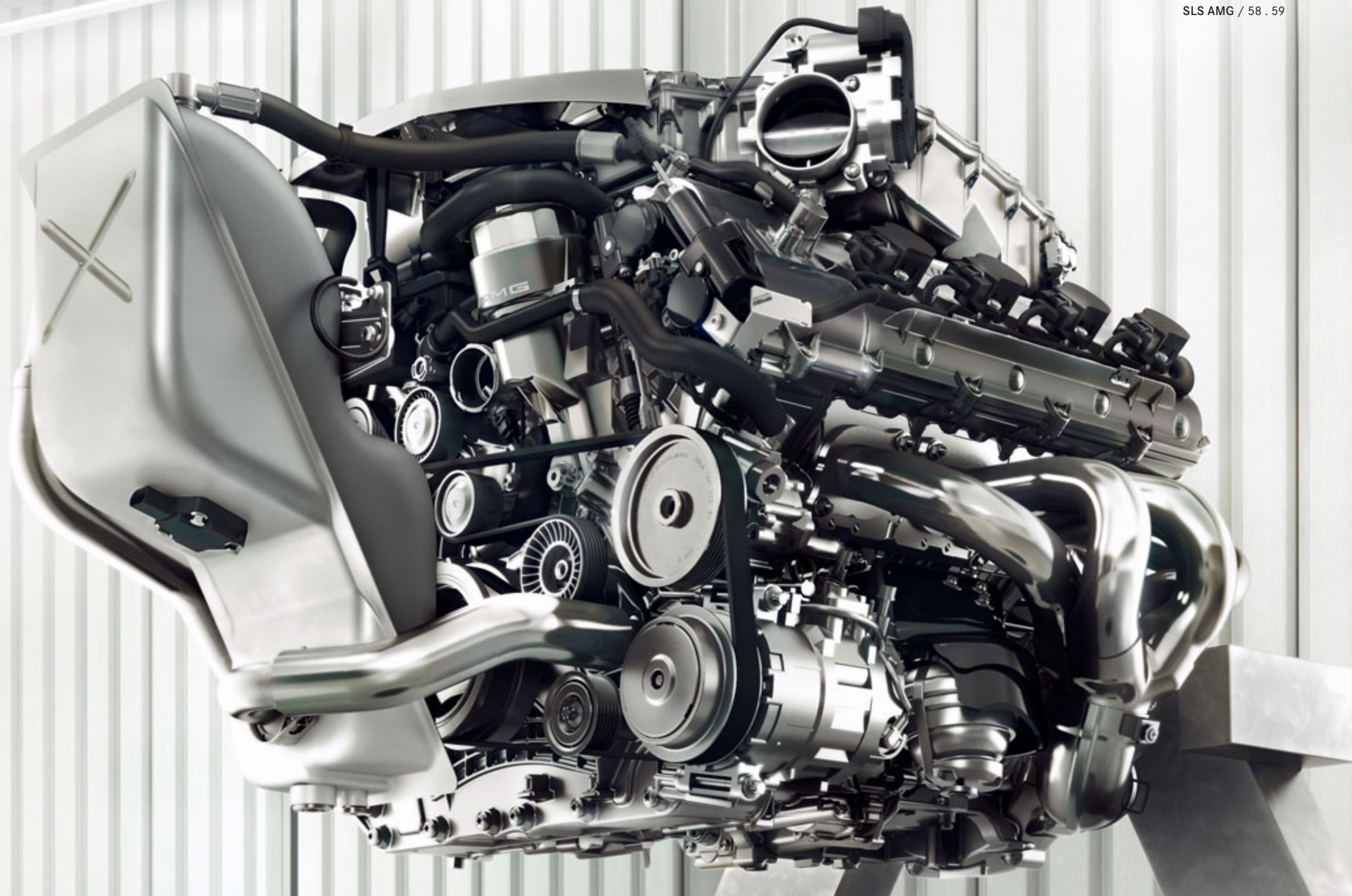

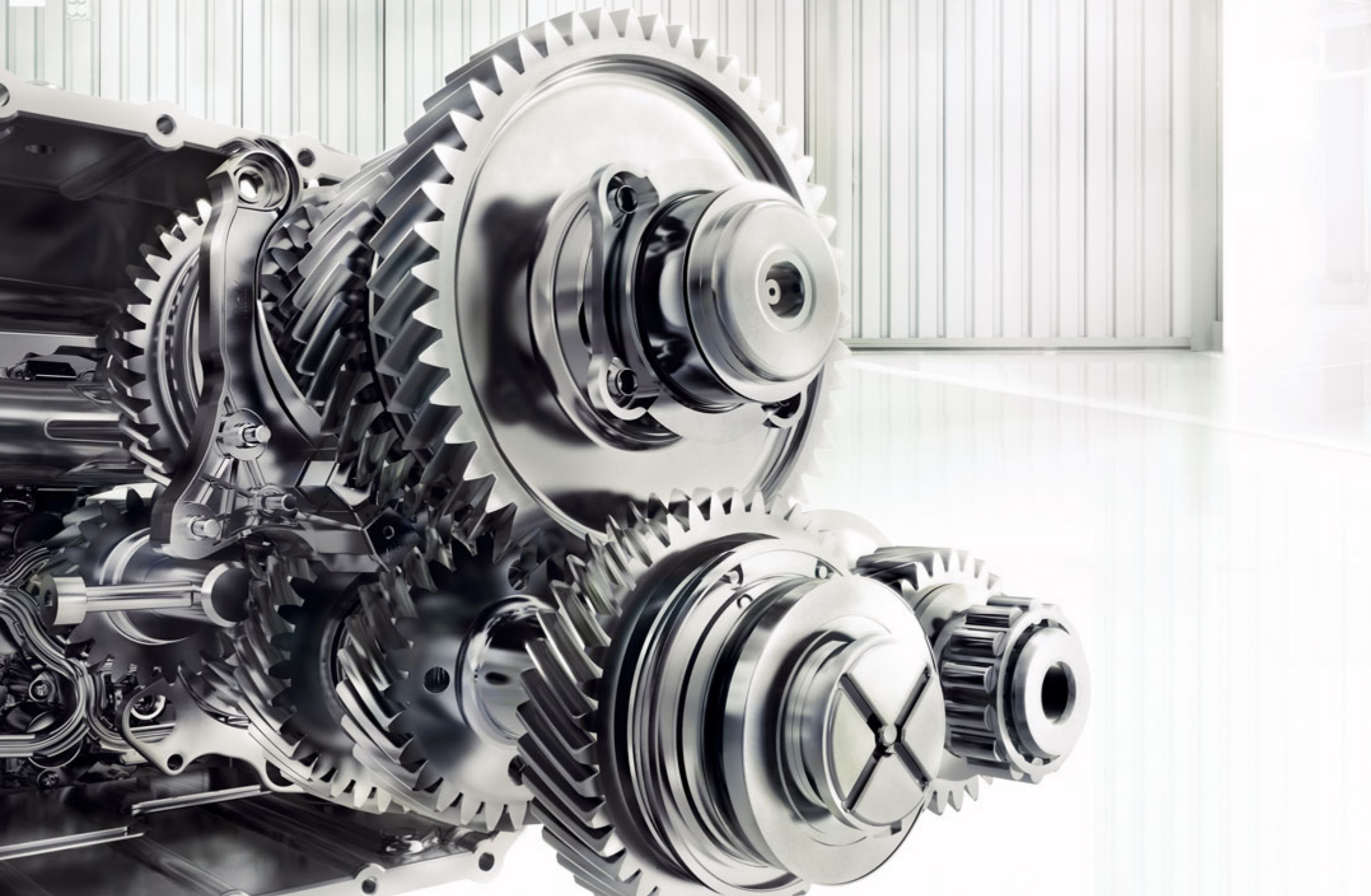



## Cut a fine figure on the race track. In designer sports gear

With this much engine output, every gear is a revelation. The new AMG SPEEDSHIFT DCT 7-speed sports transmission with an integral rear axle differential lock is in control here. The dual clutch transmission's construction principle comes from the world of motorsport: it consists of two automated dividing gears, each with one clutch. When changing gear, one clutch closes whilst the other one opens simultaneously, so that there is no interruption to power delivery during

shifting. Incidentally, all this happens in less than a hundred milliseconds – just as fast as a racing driver. The driver can choose from four transmission modes: “C” (Controlled Efficiency), “S” (Sport), “S+” (Sport plus) and “M” (Manual). The Race Start function facilitates maximum acceleration from standstill. So if you should ever find yourself unable to resist a race track, there's plenty of scope for challenging the laws of physics.



## Only the central reservation boasts better roadholding

Aluminium, steel and motorsport know-how. These are the components that make the SLS AMG's suspension so uncompromising when it comes to driving dynamics. The technical details: dual wishbones with a track rod, and independent wheel and spring location. A long wheelbase ensures straight-line stability and the wide track width more grip on bends. All in all: roadholding you can feel every second of the journey. Plus the rear aerofoil that automatically extends when accelerating from speeds of 120 km/h further improves downforce. And if one perfect suspension system is not enough for you, why not opt for three? The

AMG RIDE CONTROL sports suspension, available as an optional extra, adapts the damping characteristics in line with the driving style and the condition of the road. The driver can select from three suspension modes: Comfort (C), Sport (S) and Sport plus (S+). The coupé offers a further optional extra for all those for whom tenths and hundredths of seconds are what really matter: the AMG performance suspension. It has been fine-tuned for the race track, with tauter springs and dampers for optimised lateral dynamics.



7

6

7



## When we build sports cars we try our best to lose. Weight, of course

Less is not more – it's faster: in order to achieve the lowest weight possible, the designers were consistent in their use of aluminium for the bodyshell of the SLS AMG. The entire aluminium space frame weighs just 241 kg in the case of the coupé and 243 kg in the case of the SLS AMG Roadster. In order to achieve the weight and to render the structure as stable as possible, the engineers optimised the distribution of forces in the structure again and again. Precisely calculated aluminium castings are positioned in places which bear the brunt

of high forces. A mere four percent of the bodyshell is still reinforced with steel – where occupant safety necessitates it. So much stability and safety but so little weight – this could well be a record. And anyone for whom the car still isn't light enough can reduce its weight even further with numerous optional extras: considerably lighter AMG sports bucket seats (available only for the coupé), ceramic brake discs, forged wheels or the extensive use of genuine carbon fibre.



6



## The only door that creates, rather than taking up, room when it opens

It's fantastic that the SLS AMG Coupé is so super sporty. It's even more fantastic that its driver doesn't have to be. Because the gullwing doors make getting in and out really easy: with an entrance height of 45 cm, a distance between the open door and the ground of 1.50 m and an opening angle of 70°. It's hard to believe the gullwing doors extend outwards no more than 36.3 cm when opening – much

less than a normal car door. And it goes without saying that they can be opened fully in any conventional garage. The driver senses at first glance just how special these gullwing doors are. And so that absolutely nothing impairs the look of the perfect lines, the door handles have been fully integrated, only folding out when they are unlocked.



## High performance is our goal when it comes to safety, too

The three-pointed star on the SLS AMG's radiator is a sure sign that the weight-reducing measures aren't at the expense of hallmark Mercedes-Benz safety. On the contrary. The basis of the safety concept is the stable aluminium space frame which is reinforced with steel where occupant safety demands it. Also responsible for the high level of safety enjoyed by the driver and passenger are belt tensioners and belt force limiters. And there are no less than eight airbags in total: two adaptive airbags in the front area and two each in the side, head and knee area. Blind Spot Assist is a new feature available as an optional extra. When it

detects a vehicle in the blind spot, a red warning signal illuminates in the exterior mirror. If the driver still indicates despite this warning, an alarm also sounds. There are also numerous electronic driver assistance systems taking care of active safety. And, last but not least, there are the driver's dilated pupils. Incidentally, the SLS AMG is also streets ahead where safety in Formula 1 is concerned: as the Official F1™ Safety Car – tested and serviced by the AMG Performance Studio's specialists.







6

7

## Yet another reason to bow down. The light-alloy wheels

It's not just the body – the wheels and tyres also blend high tech and design to impressive effect. AMG light-alloy wheels produced using the flow-forming process bring increased driving dynamics and suspension comfort. They are weight-optimised – as are the forged wheels that are also available – and with their striking, puristic design blend harmoniously into the top athlete's super-fit look. They wear

tyres developed exclusively for the SLS AMG – for outstandingly high grip. Their air pressure is constantly monitored and the value for each individual wheel displayed in the cockpit. But first and foremost: the finer the wheels the better they suit the SLS AMG.



**Standard equipment.**  
7-spoke AMG light-alloy wheels, painted titanium grey with a high-sheen finish



**Optional extra.**  
5-twin-spoke AMG light-alloy wheels, painted titanium grey with a high-sheen finish



**Optional extra.**  
10-spoke AMG forged wheels, painted titanium grey with a high-sheen finish



**Optional extra.**  
10-spoke AMG forged wheels, painted matt black, rim flange with a high-sheen finish

## Pity you only ever get a fleeting glance of them as the car speeds by

There are three different wheel designs available for the SLS AMG. 7-spoke AMG light-alloy wheels are fitted as standard. Optional extras include AMG light-alloy wheels with powerful 5-twin-spoke styling or the weight-optimised 10-spoke AMG forged wheels. All three sets of wheels are painted titanium grey with a high-sheen finish. The 10-spoke design is also available painted in matt black, including a

rim flange with a high-sheen finish, which gives it an especially striking look. Every wheel brings its own interpretation of the supersport theme, but what they all have in common is a design that allows you to look through the spokes so you have an excellent view of the large AMG high-performance compound brake system. For this, too, is certainly a sight worth seeing.



Standard equipment.  
AMG high-performance compound brake system



Optional extra.  
AMG high-performance compound brake system with red-painted brake callipers



Optional extra.  
AMG ceramic high-performance compound brake system

## A stopping distance that is shorter than your wildest expectations

The AMG high-performance compound brake system offers outstanding deceleration performance and precise brake control. There is also the option of red-painted brake callipers. The AMG ceramic high-performance compound brake system is available as an option for motorsport-style braking power. Its discs are characterised by their extreme hardness as they are made of carbon-fibre-

reinforced ceramic. This reduces the weight of the brake discs by 40%, improving steering behaviour, whilst also facilitating shorter braking distances, higher fatigue strength and a longer life. At a standstill you can recognise the ceramic brake by the specially painted brake callipers.



AMG

Mercedes-Benz logo Data Race. Setup Apps NONE



GMeter Track 0-100 km

RADIO DISC NAVI TEL

Navigation and media controls including a rotary knob with an 'ON' button and a numeric keypad (0-9).



Optional extra.  
AMG Performance Media, torque, output and accelerator position display



Optional extra.  
AMG Performance Media, internet function



Optional extra.  
AMG Performance Media, race-lap analysis

## We've combined two of the world's fastest systems: www and AMG

Lap and intermediate times, oil temperature, centrifugal forces, accelerator pedal position, output and torque – professional racing drivers receive these data from their pit crew. SLS AMG drivers can get them from the optional AMG Performance Media system. The system keeps the driver updated on important vehicle data and times.

What's more, it stores all these data so that they can be analysed and compared at a later time. In addition, the AMG Performance Media system allows unrestricted high-speed internet access, enabling you to use search engines, for example. Who'd have thought that data processing could be this exhilarating?

A silver Mercedes-Benz SLS AMG Roadster is shown from a rear three-quarter view, parked in a clean, modern garage. The car's top is down. The floor is light-colored with yellow and grey diagonal parking lines. The walls are made of vertical metal slats. The lighting is bright and even.

## Closes faster than the heavens can open

No change in the weather is as fast as the soft top of the SLS AMG Roadster: it opens and closes fully electrically in 11 seconds – even during the journey, up to a speed of 50 km/h. And you need do nothing more than press a button.









Fabric top in black



Fabric top in beige



Fabric top in red

## The sky has many colours – we've added another three

In this car the sky is always pristine – even on those days when it's not blue. The soft top consists of high-quality three-ply fabric and is available in black, beige and red. In its closed state it blends perfectly with the vehicle's lines – a feast for the eyes of all fans of classic roadster design. But the soft top meets the most discerning requirements in more than just visual terms. It features a textile rain

groove integrated into the side edges of the soft top, through which the water can drain away from the vehicle. The heated rear window and the optimum thermal and sound insulation make the roadster much more than just a fair-weather vehicle.

Standard



197

obsidian black



775

iridium silver

designo



044

designo magno allanite grey



048

designo mystic white 2

## Paintwork

Just for a change the SLS AMG makes something weigh heavily on your mind: choosing from a total of nine paint colours. There are two metallic paints as standard: iridium silver and obsidian black. As an optional extra you can choose between two designo paints – the satin-finish paint designo magno allanite

grey and designo mystic white 2 – plus five other exclusive AMG paints, some of which are named after the most famous race tracks in motorsport history – Monza, Le Mans, Imola and Sepang. Even though your decision is not an easy one, it will be the right one.

AMG



047

AMG alubeam silver



054

AMG Monza grey magno



434

AMG Le Mans red



491

AMG Sepang brown



756

AMG Imola grey



## Rarely can a co-pilot have clung on to such exquisite appointments

The driver might not get much of the landscape flying past outside – but the fine interior certainly makes up for this. The AMG sports seats are made of hand-sewn nappa leather and boast contrasting topstitching – as do the dashboard, door panelling and armrests. The roof lining and the A- and C-pillar trim are in anthra-

cite-coloured Alcantara®, the footwell and rear panel are covered with a black velour carpet. So it may well have absolutely nothing to do with driving dynamics if the co-driver comes over all touchy-feely.

designo leather



black

designo Exclusive leather, single-tone



black



espresso brown



sand



classic red

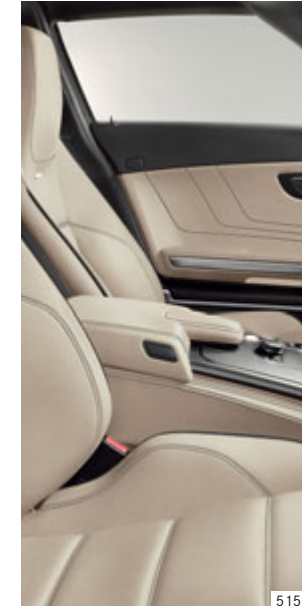

porcelain

## Colours and materials

The AMG sports seats' backrests consist of high-strength magnesium, with good lateral support – even when the going gets sporty – courtesy of deeply contoured side bolsters. That's the inner values taken care of. Craftsmanship and love of detail can be seen and felt on the exterior of the seats, too. This applies to the standard-fit appointments in black nappa leather and the optional extras in equal

measure. The latter are in designo Exclusive leather and come as a single- or two-tone variant or natural leather with a woven leather insert. You might spend much of your time driving against the clock, but you should take all the time you need for this difficult decision.



designo Exclusive leather, two-tone



554

espresso brown/black



555

sand/black



557

classic red/black



565

porcelain/black

Natural/woven leather

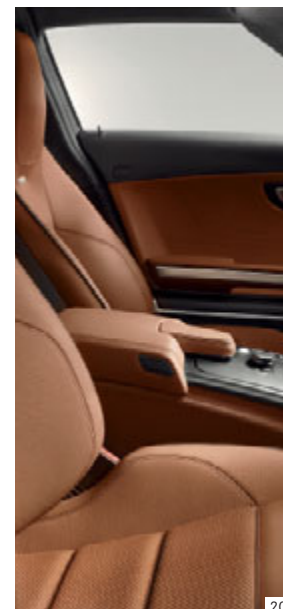

204

designo Exclusive leather in light brown



The AMG DRIVE UNIT with E-SELECT selector lever and KEYLESS-GO start function



AMG instrument cluster with 7-LED upshift indicator



AMG heated sports seats in designo nappa leather



Door sill panels in vehicle colour with nappa leather insert and embossed AMG lettering (illustration depicts coupé)

## Standard equipment | Selection

Standard equipment for the SLS AMG includes a solid-metal centre console incorporating the AMG DRIVE UNIT, the E-SELECT selector lever and the KEYLESS-GO start function. Not to mention the THERMOTRONIC automatic climate control, the PARKTRONIC parking aid, the COMAND APS multimedia

system with LINGUATRONIC, and the AMG instrument cluster with white-backlit round dials, an upshift indicator, silver dials, red needles and 360 km/h scale. Also part of the standard equipment are features such as the heated AMG sports seats upholstered in black hand-sewn nappa leather with contrasting topstitching,



Bi-xenon headlamps with integral LED daytime running lamps



Screw-on solid-metal fuel filler cap



Rear bumper with fully integral tailpipe trims

the AMG performance steering wheel with dynamic 3-spoke styling, silver-coloured aluminium shift paddles and a solid-metal insert, the roof lining and A- and C-pillar trims in anthracite-coloured Alcantara®. Standard features for the exterior include bi-xenon headlamps with integrated LED daytime running

lamps, a screw-on solid-metal fuel filler cap, 7-spoke AMG light-alloy wheels and a rear bumper with integral tailpipe trims.



AMG performance steering wheel in nappa leather/Alcantara®



AMG carbon-fibre trim with genuine carbon-fibre insert for the centre console



AMG carbon-fibre engine compartment cover



AMG Interior Carbon-Fibre package, AMG door sill panel (illustration depicts coupé)

## Optional extras | Selection

Even the utmost in enjoyment can become even more enjoyable. The optional extras offer you a choice of single- or two-tone designo Exclusive leather appointment variants, or you can opt for a natural/woven leather combination. Also available as options are the AMG performance steering wheel with Alcantara®

inserts, AMG carbon-fibre trim – with a genuine carbon-fibre insert for the centre console and the door trim strips – or the AMG Interior Carbon-Fibre package with additional carbon-fibre door sill panels and carbon-fibre seat linings. What's more, the AMG trim is also available painted in high-gloss black.



AMG trim painted in high-gloss black



Car cover



Blind Spot Assist



AMG RIDE CONTROL suspension, Adaptive Damping System with three driving modes

Also available as optional extras: an AMG carbon-fibre engine compartment cover, AMG sports bucket seats (for the coupé only), a Memory package (which can save the specific settings for the driver's and passenger seat, steering column and exterior mirror for several drivers), plus AMG carbon-fibre exterior mirrors.

The Blind Spot Assist is also available as an option to warn the driver if it registers another vehicle in the area of the blind spot. And anyone who just can't get enough sportiness can go for the AMG performance suspension for the coupé – specially developed for use on the race track.



Standard equipment.  
Central control panel for COMAND APS



Standard equipment.  
TFT colour display with 17.8 cm screen diagonal for displaying high-resolution maps



Standard equipment.  
Media Interface

## Multimedia and navigation systems

The COMAND APS multimedia system is fitted as standard on board the SLS AMG. It includes a TFT colour display, six loudspeakers, a DVD drive for audio and video – also available as a 6-disc CD/DVD changer as an option, a Music Register with a 6 GB memory for digital music and a Bluetooth® interface. The colour display also shows pictures from the optional reversing camera.

And so that you can concentrate fully on driving, the COMAND APS multimedia system with LINGUATRONIC can be controlled via spoken instructions. Those who want to quickly transfer their files from an MP3 player or smartphone to the multimedia system will also like the optional Media Interface housed in the glove compartment.



Optional extra.  
Bang & Olufsen BeoSound AMG sound system,  
250-watt subwoofer



Optional extra.  
Bang & Olufsen BeoSound AMG sound system,  
illuminated tweeter lens



Optional extra.  
Bang & Olufsen BeoSound AMG sound system,  
menu display

## Bang & Olufsen BeoSound AMG sound system

Looks like the speed record for concert halls has been broken. A high-end surround sound system developed together with Bang & Olufsen specially for the SLS AMG is available as an optional extra. Its 11 high-performance loudspeakers with a total of 1000 watts create astounding acoustics and the two illuminated tweeter lenses are a feast for the eyes. The driver can choose between the

“Reference” high-end studio sound and an expansive surround sound, and the sound fields can even be precisely directed towards the seats with the aid of the digital sound processor (DSP) – specially tailored to the interior of the coupé or roadster. Everything you need for pristine sound and a perfect listening experience.



## As far as we're concerned there's no possible or impossible. Only minor and major challenges

The AMG Performance Studio was founded in 2006 to make your AMG Mercedes even more individual and even sportier. The thing that really makes our employees' day? When they have to say "I've never come across that before!" if met with a particularly demanding customer requirement, before they set about turning your

idea into reality with zeal. Because our highly motivated specialists regard every request for particular colours or materials, for extravagant appointments or yet more dynamism as a special challenge to which they are only too glad to rise as they fulfil it with passion and meticulous precision.





# Services

**MercedesCard.** The card is your ticket to the Mercedes-Benz experience. Four times a year, we will send you the Mercedes-Benz Magazine, featuring fascinating reports from the world of Mercedes-Benz and articles about our latest vehicles. A MercedesCard also has many other uses too. As a VISA credit card, it is an internationally accepted means of payment. Further benefits are available to provide you with peace of mind, such as insurance packages for your Mercedes and other insurance services for the whole family. Further details can be found at [www.mercedes-benz.com](http://www.mercedes-benz.com)<sup>1</sup>

**Mercedes-Benz Financial Services.** Mercedes-Benz stands for quality, innovation and safety – and the same applies to Mercedes-Benz Financial Services. Our innovative leasing and financing products are tailored to your financial needs and means, making it easy for you to secure the keys to your dream car. Once you are on the road, our insurance products offer you comprehensive protection on every trip. Finally, our service products ensure that your car is always in tip-top condition whilst keeping costs transparent and easily manageable. For a detailed quotation, please contact your Mercedes-Benz dealer, who will be glad to go through the latest financial services and terms and conditions with you.

**Mercedes-Benz mobility.** Your new car comes complete with the promise of feeling safe on the road, but if you should ever need assistance, then Mercedes-Benz Service24h is there to help. Just call the freephone service hotline on 00800 1 777 7777<sup>2</sup>. The newly integrated telematics service, Mercedes-Benz Contact<sup>3</sup>, is even more customer friendly: a touch of a button is all it takes to contact the Mercedes-Benz customer centre. If you wish, the relevant vehicle and position-related data can be transmitted at the same time, thereby allowing the centre to react quickly and provide rapid on-the-spot assistance. Also standard with your new car at no extra charge is the Mercedes-Benz Mobilo<sup>4</sup> mobility package. Whether you have lost your key, had a breakdown which cannot be repaired immediately or suffered damage to the vehicle due to an accident or vandalism, Mobilo is there to help you reach your destination – anywhere in Europe. Whatever your problem, one thing is certain: you will soon be able to resume your journey.

<sup>1</sup> Information about the MercedesCard in Austria and Switzerland can be found on the Mercedes-Benz websites for these countries <sup>2</sup> Alternative: +49 69 95 30 72 77. The only charge incurred is the cost of the mobile phone call to the landline network

**Mercedes-Benz Museum.** Experience 125 years of automotive history against an architecturally impressive backdrop. Over 1500 exhibits on nine levels give you an insight into the unique tradition and powers of innovation of the Mercedes-Benz brand in Stuttgart. See the world's first two automobiles in the shape of the Benz Patent-Motorwagen (motor car) and the Daimler motorised carriage – plus the automotive future of Mercedes-Benz – in an area covering a total of 16,500 square metres. We look forward to your visit – online, too, at [www.mercedes-benz-classic.com/museum](http://www.mercedes-benz-classic.com/museum)

**Test drive.** The unique feeling of driving a Mercedes cannot be put into words. Which is why we'd like to invite you to experience it for yourself. Take a test drive and find out first hand how it feels to drive your dream car. Simply visit [www.mercedes-benz.com](http://www.mercedes-benz.com) to locate your nearest Mercedes-Benz dealer.

**Interactive Owner's Manual.** The website also offers an interactive tour, enabling you to take a closer look at your desired model. Experience key functions in detail, gain an insight into the car's inner workings or look at the benefits of each model at [www.mercedes-benz.de/owners-manual](http://www.mercedes-benz.de/owners-manual)

**Mobile internet.** Now you can access the entire world of Mercedes-Benz from your mobile phone. As well as an overview of all the passenger car models, there are insights into the entire brand world along with a wealth of entertainment offers and direct links to our range of services at [www.mercedes.mobi](http://www.mercedes.mobi)

**Service packages.** Vehicle-specific services allow you to put together an individual package for your Mercedes-Benz: for a small monthly premium the Excellent service package covers all service jobs including maintenance, wear and repairs – for up to five years. Simply present your service card and you will be safe from any financial surprises. And you can rely on the fact that your Mercedes-Benz will remain on top form for a long time to come. With the Advance service package your Mercedes-Benz will stay at its best for longer still: you will be protected against unexpected repair costs even after the manufacturer's warranty or the service package has expired – for up to ten years.

**Repair following an accident.** Should the worst come to the worst, the Mercedes-Benz accident repair service provides you with the best help available for your vehicle, which will retain its valuable safety properties. From work on the paint to bodywork or glass damage – optimally trained specialists will repair your Mercedes-Benz at your Mercedes-Benz service partner, and you will soon be back on the road again. Further information is available from your authorised Mercedes-Benz dealer.

# Dimensions<sup>1</sup> and technical data for the SLS AMG Coupé

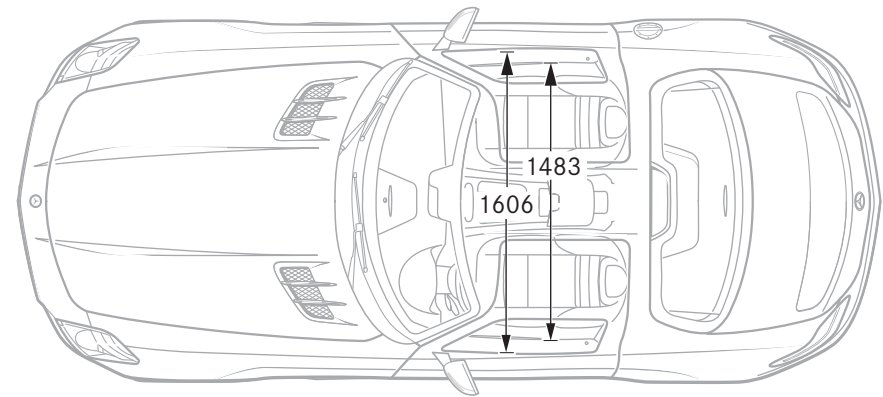
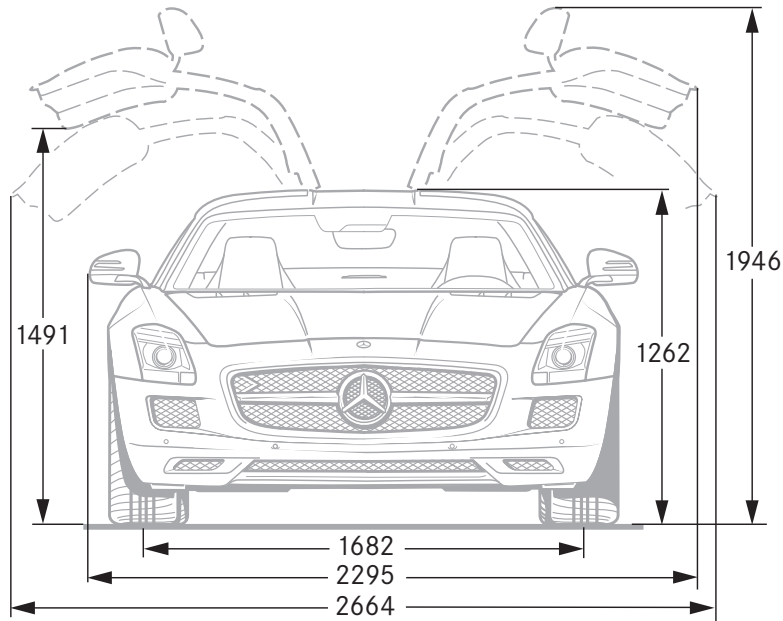

Arrangement/number of cylinders	V8
Total displacement (cc)	6208
Rated output <sup>2</sup> (kW at rpm)	420/6800
Rated torque <sup>2</sup> (Nm at rpm)	650/4750
Acceleration from 0 to 100 km/h (s)	3.8

Top speed (km/h)	317
Fuel	Super Plus
CO <sub>2</sub> emissions <sup>3</sup> (g/km) combined	308
Emission class	Euro 5
Efficiency class	G

<sup>1</sup> All measurements in millimetres. The dimensions shown are mean values and apply to standard-specification, unladen vehicles <sup>2</sup> Figures in accordance with Directive 80/1269/EEC in the currently applicable version <sup>3</sup> The figures shown have been calculated in accordance with the prescribed measuring process (Directive 80/1268/EEC in the currently applicable version). The figures are not based on an individual vehicle model and do not constitute part of the product offer; they are provided solely for purposes of comparison between vehicle models

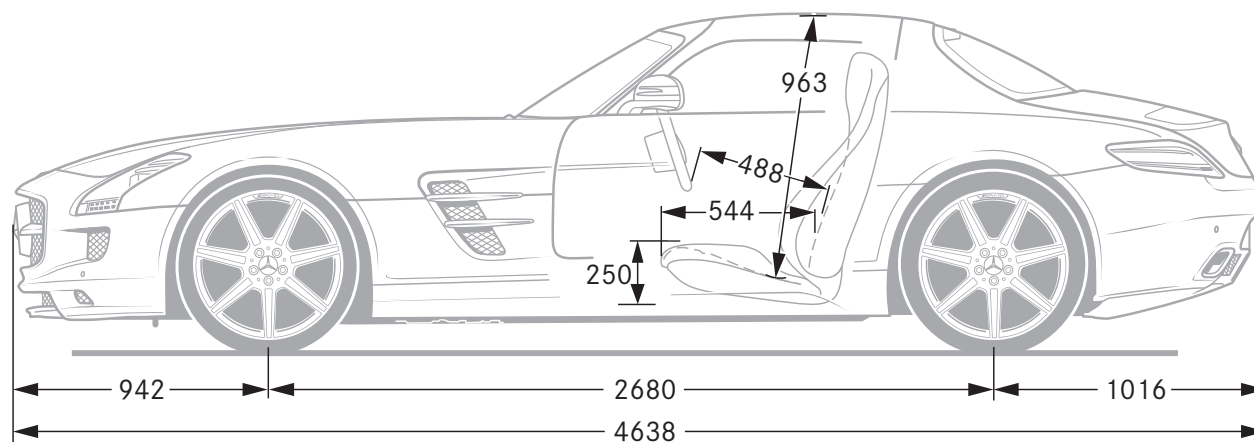
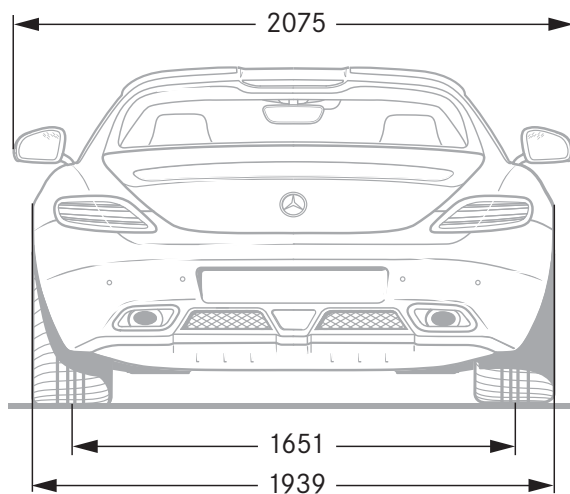

Fuel consumption <sup>3</sup> (l/100 km)			
Urban	19.9		
Extra-urban	9.3		
Combined	13.2		
Tank capacity (l)/of which reserve approx.	85 / 14		
		Front tyre size	265/35 R 19
		Rear tyre size	295/30 R 20
		Boot capacity (l)	176
		Kerb weight <sup>4</sup> (kg)	1620
		Perm. GVW (kg)	1935

<sup>4</sup> Figures according to DIN 70020 (kerb weight, fuel tank 90% full, no occupants) for standard-specification vehicles. Optional extras and accessories will generally increase this figure and reduce the payload capacity accordingly

# Dimensions<sup>1</sup> and technical data for the SLS AMG Roadster

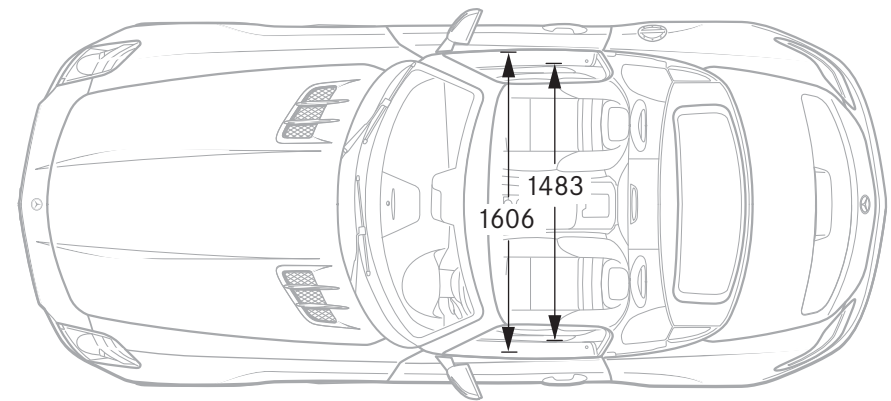
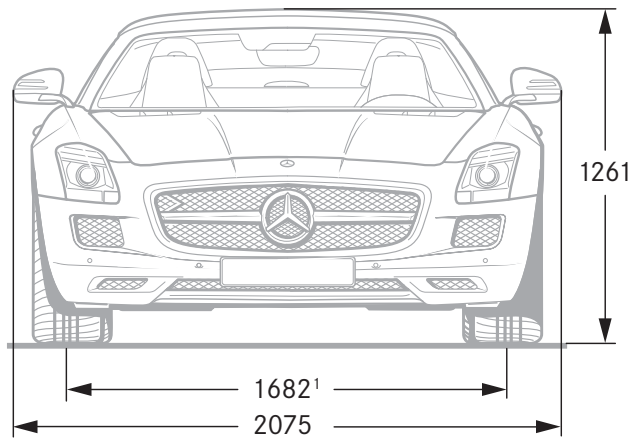

Arrangement/number of cylinders	V8
Total displacement (cc)	6208
Rated output <sup>2</sup> (kW at rpm)	420/6800
Rated torque <sup>2</sup> (Nm at rpm)	650/4750
Acceleration from 0 to 100 km/h (s)	3.8

Top speed (km/h)	317
Fuel	Super Plus
CO <sub>2</sub> emissions <sup>3</sup> (g/km) combined	308
Emission class	Euro 5
Efficiency class	G

<sup>1</sup> All measurements in millimetres. The dimensions shown are mean values and apply to standard-specification, unladen vehicles <sup>2</sup> Figures in accordance with Directive 80/1269/EEC in the currently applicable version <sup>3</sup> The figures shown were obtained in accordance with the prescribed measuring process (Directive 80/1268/EEC in the currently applicable version). The figures are not based on an individual vehicle and are provided solely for purposes of comparison between different vehicle models. They do not constitute part of the product offer

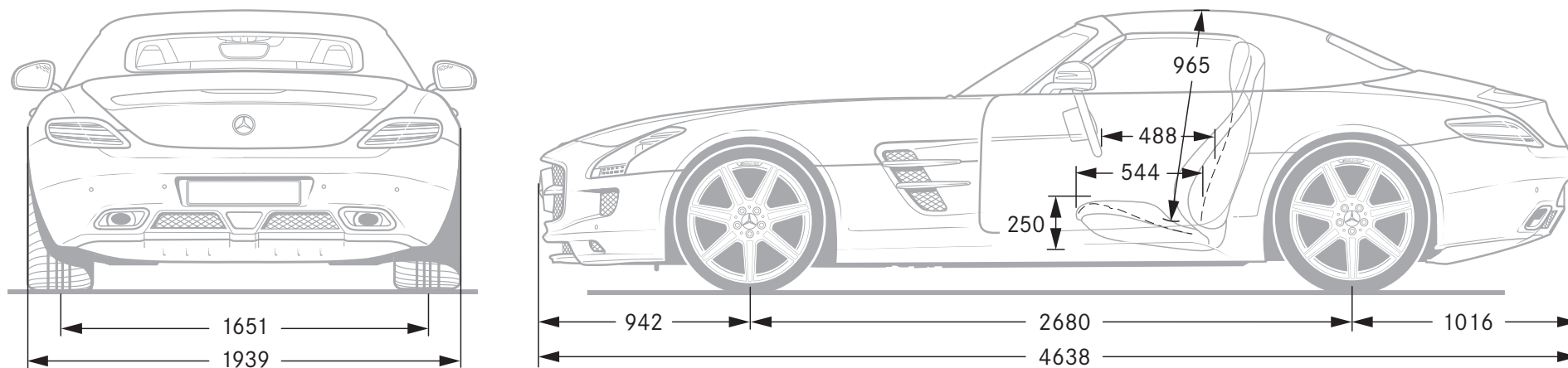

---

**Fuel consumption<sup>3</sup> (l/100 km)**

Urban	19.9
Extra-urban	9.3
Combined	13.2

---

Tank capacity (l)/of which reserve approx.	85 / 14
--	---------

---



---

Front tyre size	265/35 R 19
-----------------	-------------

---

Rear tyre size	295/30 R 20
----------------	-------------

---

Boot capacity (l)	173
-------------------	-----

---

Kerb weight <sup>4</sup> (kg)	1660
-------------------------------	------

---

Perm. GVW (kg)	1960
----------------	------

---

<sup>4</sup> Figures according to DIN 70020 (kerb weight, fuel tank 90% full, no occupants) for standard-specification vehicles. Optional extras and accessories will generally increase this figure and reduce the payload capacity accordingly

**Take-back of end-of-life vehicles.** Coming full circle. At the end of its long life, you can return your SLS AMG to us for environment-friendly disposal in accordance with the EU End-Of-Life Vehicle Directive<sup>1</sup>. But that day lies a long way off.

<sup>1</sup> Applies in accordance with national regulations to vehicles up to 3.5 tonnes gross weight. Mercedes-Benz passenger cars have met the statutory regulations governing the suitability of their design for reuse and recycling for a number of years now. A network of vehicle take-back depots and dismantlers has been established which will process your vehicle in an environment-friendly manner. The ways in which both vehicles and parts can be recovered are subject to ongoing development and improvement. Consequently, the SLS AMG will be able to comply with any future increases in the recycling quota within the stipulated time limits.

**Please note:** changes may have been made to the product since this brochure went to press (24.05.2011). The manufacturer reserves the right to make changes to the design, form, colour and specification during the delivery period, provided these changes, while taking into account the interests of the vendor, can be deemed reasonable with respect to the purchaser. Where the vendor or the manufacturer uses symbols or numbers to describe an order or the subject of an order, no rights may be derived solely from these. The illustrations may show accessories and items of optional equipment which are not part of standard specification. Colours may differ slightly from those shown in the brochure, owing to the limitations of the printing process. This brochure is distributed internationally. It provides a general indication of the range of models, features, optional extras and/or colours available in various countries. Some of the models, features, optional extras and/or colours shown may not be available in your country or may only be available in a different specification. Additionally some models, features, optional extras and/or colours may only be available in combination with others. For current and more specific information in relation to the range of models, features, optional extras and/or colours available in your country, and their pricing, you should contact your nearest authorised Mercedes-Benz Passenger Car Dealer. [www.mercedes-benz.com](http://www.mercedes-benz.com)