

FJ Cruiser



A Legend Returns.



Getting the job done. The story of Toyota Commercial Vehicles.



Getting the job done. That's been our motto for more than half a century. No matter the terrain, no matter the weather, no matter the load, our engineers' pursuit of perfection will ensure we meet our mantra. At Toyota, we know that every job matters and we know that the quality, durability and reliability we promise is crucial.

There through thick and thin.

We've done it tough since day one. Back in 1958, on the slopes of the Snowies, our very first LandCruiser was used as a tool for thousands of Snowy Mountain Hydro Scheme workers. It got them to their worksite, and home again, every day. Their back-breaking work on unforgiving and unpredictable land was shouldered by this unbreakable workhorse. No wonder it's known as the 4WD that built Australia.

Now, more than fifty years on, we're still at work building the nation. Our commercial fleet is still getting the job done everywhere and more Australians rely on us than ever before. From cattle drovers to camel catchers, boaties to brickies, our quality, durability and reliability is expected.

And still there's work to be done.

We boast the toughest, strongest, and smartest work vehicles ever made, because we've been there before. We work to bring you the best vehicles to tackle the toughest terrain on earth, and we'll continue to evolve and strive to make each Toyota better than the last.

FJ Cruiser

A Legend Returns.

Modelled from an uncompromising vision to 'go anywhere, do anything'. Built on the cornerstone of its illustrious 4WD heritage. And destined to become a legend in its own right. FJ Cruiser embodies rugged dependability, durability and grunt, with head-turning design features.



Stylistically, it makes a bold statement. Strikingly modern, the FJ's design also clearly references the past. And while its wide stance and bold colours are anything but shy of attention, it's the unfaltering 4WD capabilities of this groundbreaking vehicle that really set it apart.

Territorial advantage.

Built with purists in mind, and tested on some of the toughest terrains in Australia – from red earth to mud flats, to sheer rock climbs and slippery bitumen – the FJ doesn't balk at any challenge. And little wonder. Its 4WD capabilities, including part-time 4WD, Active Traction Control and push-button

Rear Differential Lock, make it adventure ready. And with a reinforced steel chassis, and 200kW of power, it's tough enough to go almost anywhere.

Never look back.

With FJ Cruiser, a legend has certainly been reborn. And one of Australia's most iconic symbols of 'go anywhere' toughness, has been returned to power. But when you consider its pedigree, going beyond all expectations is practically second nature.





Take on the off-road.

While the FJ Cruiser is stylish enough to be just as at home in town as it is in the outback – it's in the tough terrains it really earns its stripes. A reinforced steel chassis means it's as close to indestructible as you can get. And with a frame that's modelled from our very own Prado, it's not only built to last, it's built to test your limits.

Gripping performance.

When things get slippery, you've still got control – thanks to the FJ's A-TRC system. Ensuring excellent Limited Slip Differential (LSD) capability, A-TRC controls any acceleration slippage by distributing it across all four wheels, so you're surefooted – even in mud, or split surfaces with different levels of grip.

Add to that the stopping power of large front and rear ventilated disc brakes, as well as superb water-crossing capabilities, and you have a vehicle that can take on the adventure of a lifetime, every day.

Take control.

There's also a CRAWL Control¹ function, for the ultimate in off-road driving competence. CRAWL Control maintains a low uniform speed by automatically and independently controlling both engine output and brake input to each wheel, this allows greater concentration for the task of steering, especially on slippery and uneven gradients.

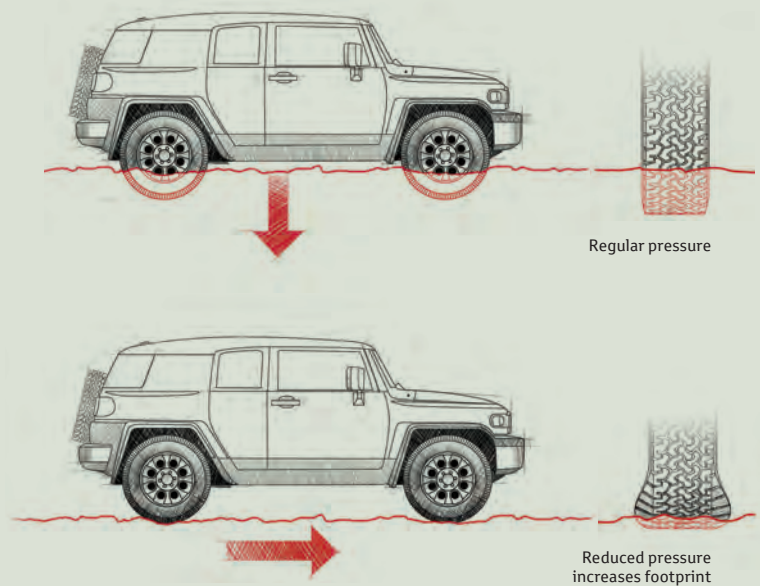

The key to driving in sand is to stay on top of it. Reducing tyre pressure, or airing down, improves "flotation" by creating a wider footprint and distributing weight across a larger area. A good rule of thumb is to reduce the tyres profile by about 25%. And always remember to reinflate the tyres to proper air pressure once you're off the sand.

¹ CRAWL Control is a driver assist technology and should not be used as a substitute for safe driving practices. The area into which the vehicle is to be driven must be visually monitored by the driver.



FJ shown with optional accessories



Your way, or the highway.

We've left the driver assist technologies to one side, and put the control of your vehicle in your hands.

Whenever you venture off the beaten path, switch to the 4WD system with selectable H4-H2 and L4 ranges for maximum control. Once low range 4WD is selected, activate the Rear Differential Lock (at the touch of a button) to disable ABS, Brake Assist, Traction Control and Vehicle Stability Control – for genuine Four-Wheel Driving at its best.

A vehicle built to handle anything you throw at it, with an impressive 224mm running clearance¹ and heavy duty front double wishbone suspension, tuned especially for Australian conditions. FJ has been pushed to the limits – testing over 100,000km to make sure it's built to last. Travelling across some of the most arduous Australian conditions, including blistering heat, rugged red earth and soft sand; jagged rocks and slick roads; bush tracks and coarse tarmac. So you know however hard you push your FJ Cruiser – it's nothing it hasn't experienced before.

FJ Cruiser can go just about anywhere; the 36-degree approach angle¹, 31-degree departure angle¹ and a 29-degree break over angle¹ ensure you're less likely to get caught short on steep climbs and descents. These being the best departure and break-over angles in the Toyota 4WD range.

¹ Some vehicle dimension figures are approximate and may vary due to options and accessory fitment.

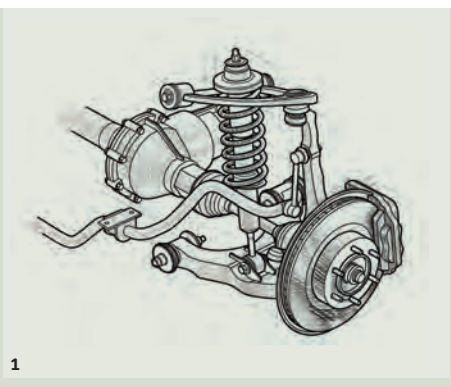

1

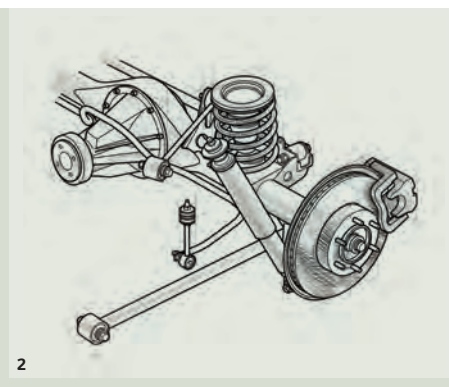

2

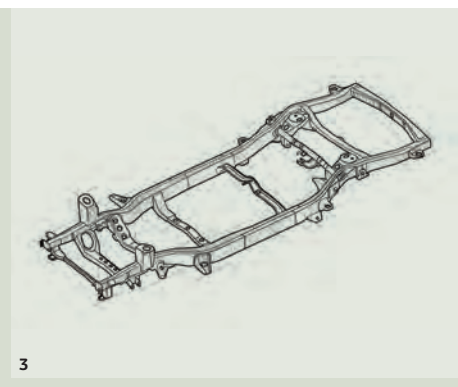

3

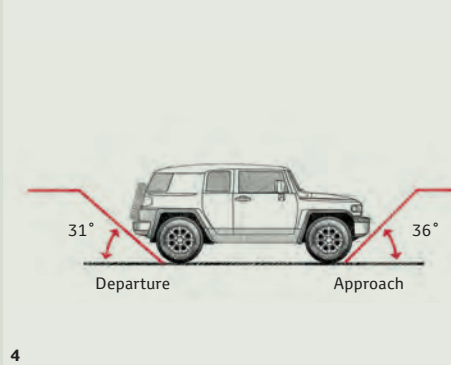

4

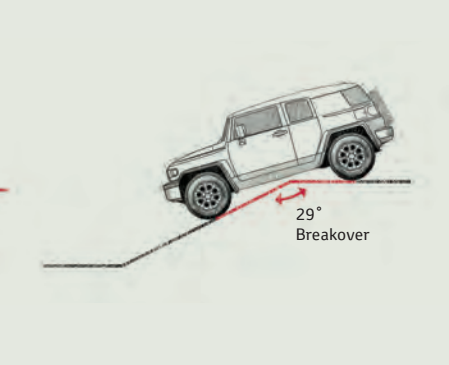

1 Front Suspension
 2 Rear Suspension
 3 Reinforced Steel Chassis
 4 Before taking on steep slopes or crossing over a ridge, be aware of your clearance angles. The greater the approach and departure angles, the steeper the slope you can drive onto or off without scraping your bumpers, while a greater breakover angle helps avoid scrapes on the undercarriage.

Correct angle

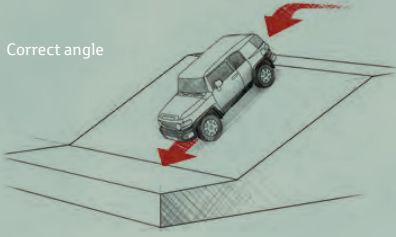

Incorrect angle

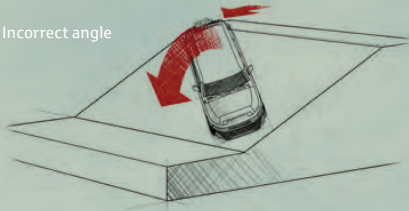

Before tackling a steep hill, inspect it first on foot. With the transfer case in Low, attack the slope at a 90° angle to help avoid rolling over. Ascend in a gear high enough to prevent wheelspin, but low enough to provide power. Descend slowly in 1st gear, using engine braking, not the brakes, to maintain traction. Also, watch your clearance angles at the top and bottom.

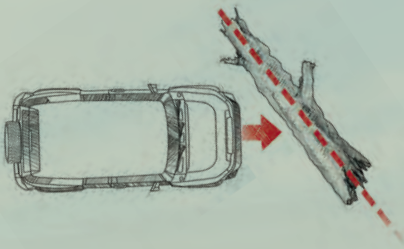

When faced with a large obstacle, like a rock, fallen tree or gully, the best way to take advantage of your vehicle's ground clearance and avoid damaging your undercarriage is to attack it diagonally. If you should happen to make contact, the FJ is armed with standard skid plates.







Quick Facts

- 200kW 4.0L V6 engine with dual VVT-i
- 5 speed automatic transmission
- 72L fuel tank + 87L subtank
- Reverse opening rear access doors
- 17" alloy wheels with chunky 265/70R17 tyres

FJ shown with optional accessories

Go hard, or go home.

Explosive power, and uncompromising grip on road or off – the FJ Cruiser's performance has to be experienced to be believed. One of the most powerful vehicles in its sub-segment, its 4.0-litre V6 petrol engine gives you 200kW of power and 380Nm of torque under your right foot. Its awesome power is delivered by an electronically controlled A750F automatic, gated shift transmission with cooler.

FJ isn't carrying any unnecessary weight – leading its class with a power-to-weight ratio of 102kW per tonne. And it's nimble too, thanks to traction control technology that prevents wheelspin in the toughest of terrain.

And even with a braked towing capacity of 2250kg,¹ its power is delivered responsibly. In fact, the FJ Cruiser offers a combined cycle fuel economy of 11.4L/100km² – which, matched with a 72-litre fuel tank and 87-litre subtank, gives you more than 1390km² per fill-up. And if you stick to the highway, that jumps to more than 1700kms²

Ready for anything... even you.

We've pioneered measures to reduce noise, vibration and harshness, to ensure a quiet, comfortable ride. We've also stiffened the shock absorbers slightly, and custom-tuned the power steering, to give you an authentic ride, and sharp, responsive handling.

¹ Towing capacity subject to regulatory requirements, towbar design, vehicle design and towing equipment limitations. Ask your Dealer for details of Toyota Genuine Towbar capacity and availability.

² Fuel consumption will vary depending on driving conditions/style, vehicle conditions and options/accessories. Source of fuel consumption data: ADR81/02 combined cycle.



A tough nut to crack.

When you're taking on the great outdoors, getting in a few tough scrapes is all part of the fun. But whether you're out in the scrub, or scrambling around town, it's good to know that when things get serious, the FJ Cruiser is packed with safety features to help keep you and your passengers safe.

Out-thinking the unthinkable...

Advanced safety technology has been built into every aspect of the car – with an impressive array of systems designed to help avoid accidents before they happen.

- Vehicle Stability Control (VSC) manages the brake or engine force going to each wheel during cornering, so any understeer or oversteer is quickly and automatically corrected.
- ABS brakes with Electronic Brake-force Distribution (EBD) come standard, ensuring smooth, no-lock braking in any conditions.

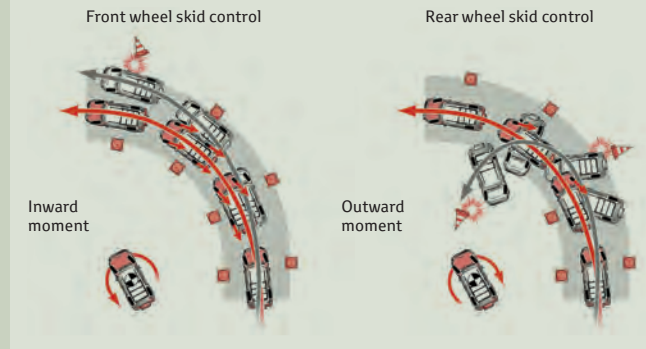

Above: VSC and A-TRC
Below: ABS (Anti-lock Brake System)

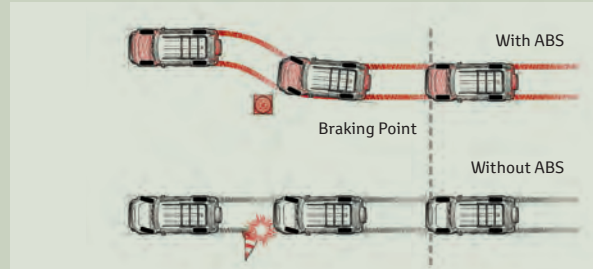

Rear seatbelts



Airbags



Rear disc brake



Front disc brake



FJ shown with optional accessories

- Hydraulic Brake Boosters in both the front and rear brakes provide even stronger braking capacity, and Brake Assist (BA) interprets a quick hard push of the brake pedal as emergency braking and supplements the braking power so that the car slows more rapidly.
- Traction Control (TRC) takes the guesswork out of slippery roads by controlling wheel spin when accelerating.

...And protecting what matters.

Should an accident ever occur, the FJ's passive safety features are quick to activate. With six SRS airbags – driver and front passenger, front-seat side airbags and full-length side curtain-shield airbags – every passenger is protected from impact. Front seats come equipped with active headrests which help reduce whiplash injury from rear collisions, and three point Emergency Locking Retractor (ELR) type seatbelts with pretensioners which lock up and force limiters which relieve the pressure in the event of an accident. Even little ones get big consideration, with three child restraint anchorage points in the rear seats.

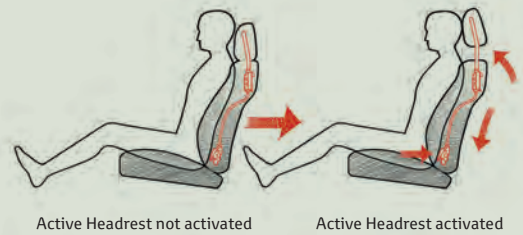

Above: Active Headrest
Below: Pretensioner and Force Limiter





Rear access door design



Glass hatch



Rear cargo space



Cargo room



Water-repellent seat facing



Spare wheel cover and reversing camera



Multi Information Display



Rear-view mirror with integrated 3.3" reversing camera display¹

The flexibility to go anywhere.

Unbelievably versatile, the FJ's flexible seating arrangement means you can adapt the cargo space to match your expedition – packing in anything from a full set of luggage or camping gear, to mountain bikes and sporting gear for the whole team. The reverse opening rear access doors and rear seat assist grips mean back-seat passengers can get in and out with ease, and the rear luggage door makes it easier to load those big items. There's even a glass hatch that's perfect when you need to grab something out of the boot on the fly.

Eyes in the back of its head.

Now even going backwards has been advanced out of sight. The automatic anti-glare rear-view mirror of the FJ Cruiser is fitted with a reversing camera¹ monitor that activates when the vehicle is in reverse. This helps give you the best possible view of what's behind you. And reverse parking sensors¹ make tight spots simple, letting you know just how close you are to obstacles to the rear of the vehicle. While the remote central locking and immobiliser system help ensure your FJ Cruiser will always be right where you left it.

Stay cool.

No matter how hot the going gets, you'll always keep your cool thanks to the easy-to-use air-conditioning system. While privacy glass on the rear side, quarter and back windows ensure your drive is completely your own – because a vehicle that commands this much attention is bound to turn heads.

All types of tough.

For muddier expeditions, triple windscreen wipers will help keep your sights perfectly clear. They provide complete coverage for the front windscreen, while diffusion-type nozzles wash away any dirt you might have picked up on your last off-road adventure. There's also front and rear mud guards to help stop splatters, before they reach your paintwork.

1 Reversing Camera/Park Assist is designed as a driver assist device only and should not be used as a substitute for skilled driving and/or safe parking practices. The area into which the vehicle is to be driven must be visually monitored by the driver.





Ordinary doesn't get a look in.

Take a look inside the FJ Cruiser, and you'll find a serious piece of industrial design. With its durable rubber floor, cavernous space and body coloured highlights in the dash and door trims, it has a style all of its own. The striking horizontal and vertical lining throughout the car not only commands attention, but gives you more room up front for a truly unique driving experience.

And of course, it doesn't get any better than the view from the driver's seat, with a premium steering wheel with audio controls, and a bold Multi Information Display mounted high on the dashboard that provides compass and inclinometer function to assist the off-road driving experience.

A classically styled instrument panel gives you complete command over the vehicle. Featuring A-TRC, Rear differential lock and VSC/Traction Control switches, you can easily set your Cruiser up for whatever challenge you want to throw at it.

Score more.

The FJ Cruiser isn't just built to endure – it's built to explore. New unknown places can sometimes lead you off course but with the FJ Cruiser's Satellite Navigation System^{1,2} helping to keep you on the right track, wrong turns are a thing of the past. If your adventure calls for some road music, the FJ Cruiser's single CD audio system with 6.1" LCD touch screen, Bluetooth™³ as well as the addition of a USB input to plug in compatible iPods®⁴ and MP3 players – makes it easier to pick the perfect tune and the FJ Cruiser speakers make that soundtrack boom. Featuring eight speakers, including a pair of technologically advanced 'Exciter' speakers that use the roof itself to spread sound throughout the cabin – every passenger gets the same intense sound.

The out-there interior.

The FJ Cruiser's seating capabilities ensure that every passenger is fit to tackle even the toughest driving experiences. Manual eight-way adjustment for the driver's seat and active headrests provide versatility for the driver – so they're not only comfortable, but better positioned to conquer any environment. All five seats are padded – with fold-down armrests in the front and removable seat cushions in the rear for increased storage capacity. And each seat is clad with water-repellent fabric facings – so any mud, rain or dirt you encounter doesn't stick around for the next trip.

1 Current navigation mapping database encompasses major capital and primary national road networks, as well as offering some coverage in regional areas.

2 Standard from January 2012 production.

3 The Bluetooth™ word mark is owned by The Bluetooth SIG, Inc. Not all devices will be compatible and functionality will vary depending on the device.

4 iPod® is a trademark of Apple, Inc. Not all devices will be compatible and functionality will vary depending on the device.





Tough stuff.

From extra protection for your paintwork, to roof racks and rock rails, it's easy to customise your FJ Cruiser to your lifestyle. Check out our range of Toyota Genuine Accessories, and select your own personal touch to make your FJ Cruiser stand alone.



Headlamp Cover and Bonnet Protector
(Sold separately)



All Weather Rubber Cargo Mat



Rubber Floor Mats



Alloy Nudge Bar



Towbar, Towball and Trailer Wiring Harness¹
(Sold separately)



Roof Rack System²

IMPORTANT NOTICE: Some Toyota Genuine Accessories are not applicable to all models/grades. Please also consider the mass of your load to ensure you will not exceed the maximum allowable individual axle capacity, Gross Vehicle Mass and/or Gross Combined Mass of the vehicle. Refer to the Accessories brochure (available from your Toyota salesperson) or visit toyota.com.au for details on warranty and toyota.com.au/vehiclepayload for details on vehicle payload, to help determine which Accessories are suitable for your vehicle. Pictured Accessories are sold separately. Accessory colours shown may vary from actual colour due to the printing process.

All Toyota Genuine Accessories purchased and fitted to a Toyota are warranted for the remainder of the New Vehicle Warranty or 12 months, whichever is greater. Toyota Genuine Accessories purchased from an authorised Toyota Dealer over the counter are warranted from the date of purchase for one year. Conditions apply. The Toyota Genuine Accessories Warranty does not limit and may not necessarily exceed your rights under the *Competition and Consumer Act 2010*.



Weathershields
(Sold separately)



Front Vest Seat Covers



Satellite Navigation Audio System³



Rock Rails
(RH/LH sold separately)

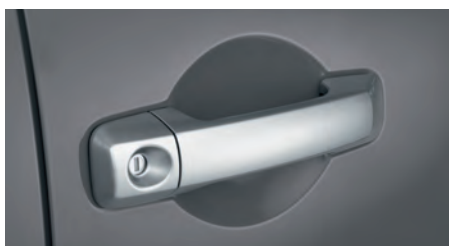

Protective Film
Door Handle Paint Protection

1 Towing capacity subject to regulatory requirements, towbar design, vehicle design and towing equipment limitations. Ask your Dealer for details of Toyota Genuine Towbar capacity and availability.

2 Roof racks sold separately.

3 Current navigation mapping database encompasses major capital and primary national road networks, as well as offering some coverage in regional areas.



FJ shown with optional accessories

Exterior Colours

- A Ebony
- B Sandstorm
- C Military Blue
- D White
- E Orange Clay
- F Cement¹
- G Jungle Green



NOTE: All FJ Cruisers come with White Roof
 1 Paint featured is an optional extra at additional cost



The Toyota Advantage.



Capped price servicing.¹

The FJ Cruiser comes with Toyota Service Advantage. That means you'll pay the same low capped price from one eligible logbook service to the next¹. So you'll enjoy the peace of mind of knowing in advance what your maximum servicing costs will be.

Better still, your Toyota will be serviced by Toyota-trained technicians who know your vehicle inside out and use Toyota Genuine Parts. For the full benefits of Toyota Servicing Advantage consult a Toyota Dealer or visit toyota.com.au/advantage.



We've got your back.

Every new Toyota is built to exceptional standards, which is backed by a 3 year/100,000km² warranty, giving you the peace of mind to feel confident for years to come.



Finance to get you going.

Sometimes you need just a little help to get up and running. Toyota Finance³ can offer you a wide range of vehicle financing. From personal loans to leasing for all kinds of business, we can help.



Even more protection.

Everyone needs vehicle insurance, but take out our Comprehensive Motor Vehicle insurance and you'll get a policy packed with a great range of benefits.

These include:

- Where your Toyota becomes a total loss, is under 3 years old and has less than 100,000km on the clock, we'll replace it with a brand new Toyota vehicle.
- We'll also promise to use genuine new Toyota parts to repair your vehicle if it is less than 5 years old.
- And we'll guarantee the quality of workmanship on all authorised repairs as long as you remain the owner of the vehicle.

Toyota Insurance also offers Finance Gap Insurance, Payment Protection Insurance and Extended Warranty Insurance.⁴



Extend your peace of mind.

Extend your original factory warranty by up to 3 years with the Toyota Extra Care Extended Factory Warranty. Available on most new and used Toyotas,⁵ it will give you extra peace of mind – as will membership to our Roadside Assist service, offering breakdown assistance 24/7. Rest assured should your vehicle be immobilised by a roadside breakdown or accident, help is never more than a phone call away with Toyota Extra Care Roadside Assist.

Discover the full range of Toyota products and services and find your nearest dealer at toyota.com.au

1 Maximum payable for standard scheduled logbook servicing (normal operating conditions) until first of 3 years or 60,000kms (whichever occurs first) (up to the first 6 services). Excludes Government & Rental vehicles. Contact your Toyota Dealer or go to toyota.com.au/advantage for other exclusions, eligibility and full details.

2 New Vehicle Warranty expires 3 years from date of first delivery or 100,000 kms, whichever occurs first. Refer to the warranty conditions. The New Vehicle Warranty does not limit and may not necessarily exceed your rights under the *Competition and Consumer Act 2010*.

3 Toyota Finance is a division of Toyota Finance Australia Limited ABN 48 002 435 181, Australian Credit Licence No 392536.

4 Terms and conditions apply. Before making a decision about any of the insurance products, please refer to the current Product Disclosure Statement (PDS) for the relevant product available from participating dealers, via the Toyota Insurance website at toyotainsurance.com.au or by calling 137 200. Toyota Insurance is a division of Aioi Nissay Dowa Insurance Co., Ltd. ABN 39 096 302 466 AFSL Number 254489 (Andia). Nothing within the Toyota Insurance Extended Warranty products affects any statutory rights you may have under the *Competition and Consumer Act 2010*.

5 The Toyota Extra Care Extended Factory Warranty Agreement is between Toyota Motor Corporation

Australia Limited ABN 009 686 097 (TMCA) and the purchaser of the motor vehicle and is administered by Toyota Financial Services (TFS) a division of Toyota Finance Australia Limited ABN 48 002 435 181 on behalf of TMCA. Terms and conditions apply. Available on most new and used Toyota vehicles up to 8 years old that have travelled less than 120,000 kms. For more information visit toyotaextracare.com.au. Nothing within the Toyota Extra Care Extended Factory Warranty product affects any statutory rights you may have under the *Competition and Consumer Act 2010*.

IMPORTANT NOTICE – PLEASE READ: Toyota Australia has used its best endeavours to ensure this material is accurate at time of printing. However, all information must be confirmed with your Toyota dealer at the time of ordering, as specifications and details will change over time. Colours displayed here are a guide only and may vary from actual colours. To the extent permitted by law, Toyota Australia will not be liable for any damage, loss or expense incurred as a result of reliance on the information and photos contained in this material. Material distributed in Western Australia by or on behalf of Prestige Motors Pty Ltd (for vehicles) and by Eastpoint Pty Ltd (for parts/accessories). Toyota Australia makes no warranties regarding (and will not be liable for) the accuracy of materials distributed in Western Australia. PART NUMBER: FJCRUISER0213. VALID: X4465-1. PRINTED: FEBRUARY 2013. GTO1466.

“We are a group of passionate perfectionists who can't let well enough alone... that's Toyota. That's the spirit. And that's our contribution to the world.”

— Eiji Toyoda

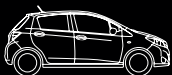

Yaris

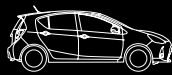

Prius c

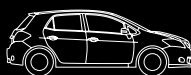

Corolla



86



Rukus



Prius



Prius v

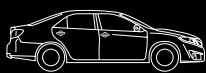

Camry

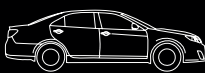

Camry Hybrid

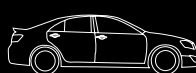

Aurion



Tarago



RAV4



Kluger



FJ Cruiser



Prado



LandCruiser 200 Series



HiLux



LandCruiser 70 Series



HiAce Van

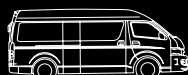

HiAce Commuter Bus

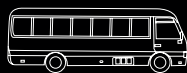

Coaster