

The SLK-Class.



Mercedes-Benz

This Brochure is prepared by Daimler AG and it predominantly reflects the capabilities and performance of vehicles sold in Europe.

Some characteristics, capabilities, performance features and optional extras (e.g. towing systems) may not be available or may not apply in Australia under Australian conditions. The information in this Brochure is therefore indicative, illustrative and provided only for guidance and should not be relied on. To obtain current and accurate information on a vehicle and any options applicable to Australia, contact your local authorised Mercedes-Benz dealer.

The background of the advertisement is a vast, flat, cracked landscape, possibly a salt flat or a dry lake bed, under a cloudy sky. In the distance, there are low mountains or hills. The overall color palette is muted, with earthy tones and soft lighting.

The SLK-Class. Your closest relationship with the road.

One look is all it takes: the forwards thrust is signalled loud and clear. Long bonnet, short overhangs, the visual focus far back. And as you drive, the roadster delivers what its design promises. Dynamism and agility are unparalleled, courtesy of the suspension with its sporty tuning, a body designed to meet discerning requirements and the utmost attention to detail when it comes to the teamwork carried out by the engine and transmission. Powerful engines place a high torque at your disposal. Alongside the good response, impressive acceleration and ability to perform, the car is characterised by a high level of efficiency, whilst the comfort and quality feel are hallmark Mercedes-Benz.

The interior sparkles with high-quality materials, processed with the greatest of care, and sophisticated ergonomics. Thanks to optional extras such as AIRGUIDE, nothing more than a gentle breeze can now get in the way of pleasurable open-top motoring. And if it should rain, the optional panoramic vario-roof with MAGIC SKY CONTROL enhances transparency even after closing time. The SLK is also right out in front where handling safety is concerned: with lots of driving assistance systems and an extensive safety concept which was developed specially for the roadster.

Guide to the vehicles shown here:

3 | Mercedes-Benz SLK 200

palladium silver metallic

5-spoke light-alloy wheels, bengal red nappa leather,
light longitudinal-grain aluminium trim

5 | Mercedes-Benz SLK 250

designo hyacinth red metallic

AMG 5-spoke light-alloy wheels, black leather,
light longitudinal-grain aluminium trim

Vision.

26 | Moving innovation

Drive system and chassis.

28 | Petrol engines

30 | Diesel engine

31 | Transmissions

32 | Chassis and suspension

Safety.

34 | Integral safety concept

Comfort.

38 | Multimedia systems

39 | Assistance systems

40 | Open-air comfort

41 | Roof and space

42 | Climate control and lights

43 | Seats

AMG.

44 | SLK 55 AMG Exterior

46 | SLK 55 AMG Interior

48 | SLK 55 AMG Technical features

49 | AMG Performance Studio

Equipment and appointments.

50 | Upholstery and trim

56 | AMG Line

60 | designo

62 | Standard equipment

64 | Optional extras

66 | Wheels

68 | Genuine Accessories

70 | Services.

Facts and colours.

72 | Dimensions

72 | Paintwork

73 | Technical data



Precision driver meets
precision machine.



Pepper for the salt lake.



A single glance is sufficient: your pulse accelerates from 0 to euphoria in a few seconds. The SLK symbolises roadster genes and sports car evolution, progress with maturity, style and intensity. And the name Mercedes-Benz stands for the fact that it cuts just as fine a figure on the tarmac as it does in the eye of the beholder.



SLK 250

D S LK 1721



A dab of the right foot – and the machine responds within fractions of a second. Like billions of tiny salt crystals bursting beneath the powerful wheels. What follows is performance par excellence. The dynamic suspension responds as if it were at one with the road. The driver's senses come alive. It's a gut feeling. Like falling in love for the first time.





One of the brightest stars.

Even a wonderful day must come to an end at some point. And give way to an excitement-filled night. Even after the SLK has come to a halt, the happiness hormones still race from head to foot. Take a deep breath, get out and take another look at the roadster. After a drive in the SLK, its muscular appearance seems even more logical. Its dynamic silhouette even more appealing. As well as being built for the road, the SLK is designed to thrill.





A view from inside a car looking out at a sunset over a body of water with mountains in the background. The sun is low on the horizon, creating a bright glow and lens flare. The water is dark with white-capped waves. The mountains are silhouetted against the bright sky. The car's interior is visible in the foreground, including the window frame and a portion of the dashboard.

Tight bends, long stretches and ambitious driving manoeuvres – one of the sources of the SLK's requisite effortless superiority are its numerous driving assistance systems. They are in a position to assess attention levels, maintain distance and speed, and prepare braking manoeuvres. And they are mostly active before you even know you need them.



You can see the fire in its eyes.



A high-angle, close-up photograph of the interior of a red Mercedes-AMG GT. The focus is on the black leather steering wheel with the Mercedes-Benz logo in the center and silver accents. Behind the wheel, the instrument cluster features three analog gauges with red needles and a central digital display showing '14.0°C' and '16:20'. To the right, the center console has a large infotainment screen displaying 'SWR2' and various control buttons. The car's body panels are a vibrant red, and the overall lighting is dramatic, highlighting the textures of the leather and the metallic elements.

1.20 cubic metres: all you need
to hone your own driving style.

It's great when you can take the feeling of having arrived with you when you hit the road. The sports steering wheel fits comfortably in your hands. All the functions are intuitive to use, while the seats feel as if they have been designed around you. The art here lies in making something so highly practical so easy on the eyes.



At last a roadster that even releases endorphins when you're refuelling.

Sunshine as far as the eye can see. Thirst is its constant companion. That doesn't impress the SLK very much. Lightweight construction, optimised engine technology measures that pay. With more pleasure per tank and a better conscience with every journey.











A silver convertible is shown from a low-angle, rear-quarter perspective, driving on a wide, light-colored desert road. The car is moving towards the right, and a large plume of dust or sand is kicked up behind it, creating a sense of motion. The background features a range of mountains under a clear, bright sky. The overall scene conveys a sense of freedom and open-air driving.

Perfection from tip to toe.

Feeling the wind blowing through your hair doesn't have to mean frozen ears. The roadster offers optional technical and aerodynamic features to ensure virtually draught-free open-top motoring - and that your hair still looks fabulous for your late-night dinner date.

Under a starlit roof.

Summer night. The stage is set for a premiere. The SLK proudly presents the sky - in the closed vehicle. It's all thanks to the panoramic vario-roof - also available with MAGIC SKY CONTROL as an option.









The ignition is at rest
but the passion burns on.

An encounter comes to an end. At least for the time being. For the SLK follows an extensive safety concept, with a reinforced body befitting a roadster, plus large headbags and crash-responsive head restraints. And something else is certain: you want to get in again and again.

What makes a car a Mercedes?

Deep-rooted traditions: in our case, it is innovative traditions that run deep. We've gone along previously untravelled roads. Setting milestone after milestone. The first car with a crumple zone, the first ABS, the first diesel car. The first car. And whilst it's nice to look back, we'd much rather look forward.

Mercedes me – welcome to a world that revolves entirely around you. We focus on people. No more so than when we developed a new platform for you to keep in close contact with Mercedes-Benz. With services that are tailored to your needs. “connect me” connects the vehicle to your world of experience, to everything that is important to you. “move me” provides new mobility solutions. And “inspire me” gives you an exclusive insight into the future of mobility. Your gateway to a fascinating world: www.mercedes.me



Mercedes-Benz Intelligent Drive – on the road to accident-free driving. We develop intelligent technologies that actively assist the driver and make driving tangibly easier. Valuable assistance systems are already available in your Mercedes-Benz: they help to maintain the distance to the vehicle in front automatically, brake the car when necessary and warn against imminent rear-end collisions or vehicles in the blind spot. The sensors of the driving assistance and safety systems are linked intelligently. Potential hazardous situations are detected earlier than ever and consequently avoided with increasing regularity. Discover the fascinating world of Mercedes-Benz Intelligent Drive at www.mercedes-benz-intelligent-drive.com

BlueEFFICIENCY – our vision of emission-free driving. Sustainability is a big word. And it's a prime consideration in absolutely everything we do. From minimising the environmental impact of our production operations to alternative drive concepts.

The aims are ambitious, as you can see. But what could be better than seeing these aims achieved whilst on a long drive in a Mercedes?

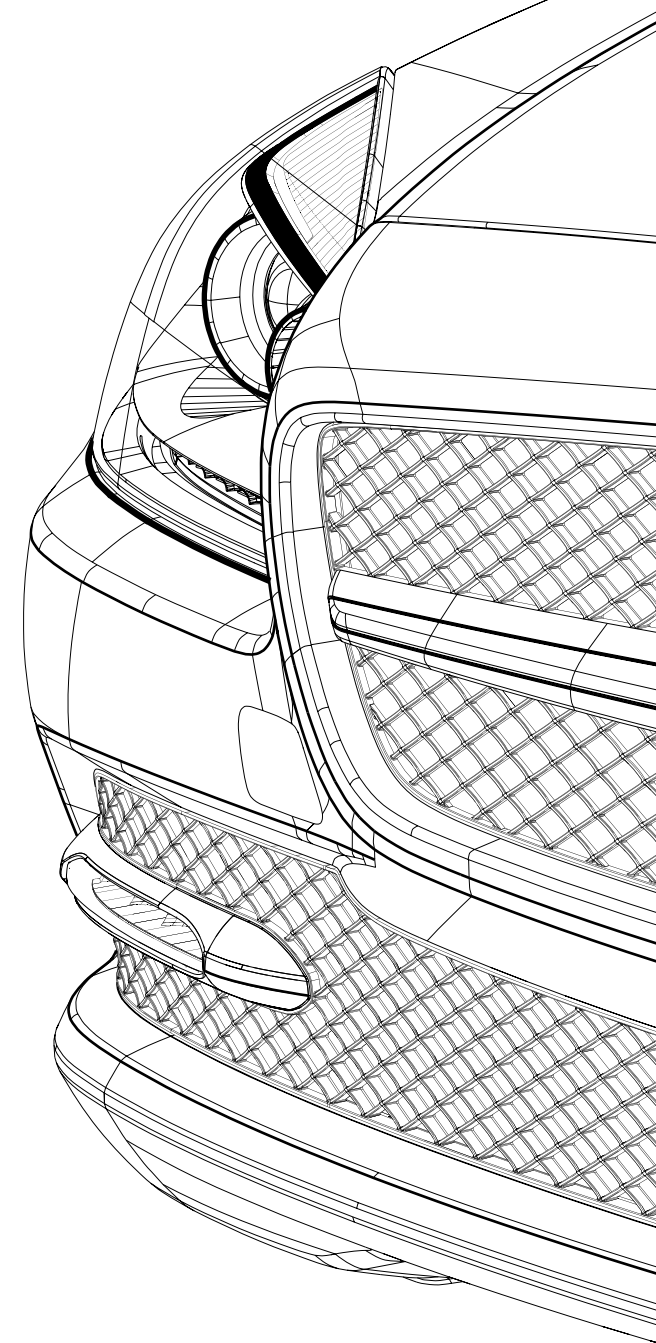

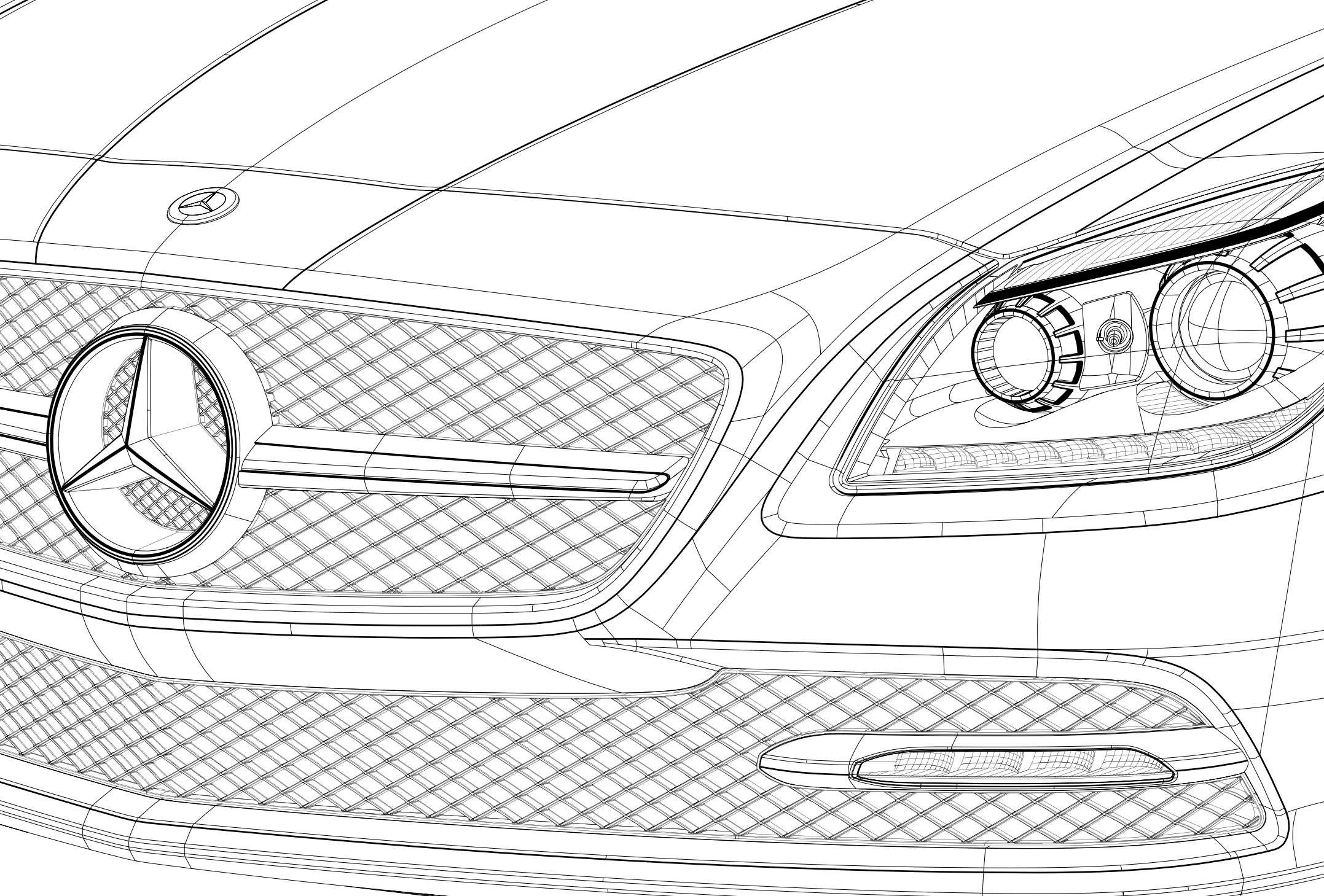

Petrol engines.

Fun at the wheel and environmental awareness are not contradictory concepts here: with powerful engine technologies that also reduce fuel consumption and CO₂ emissions, as proven by the SLK's petrol engines.

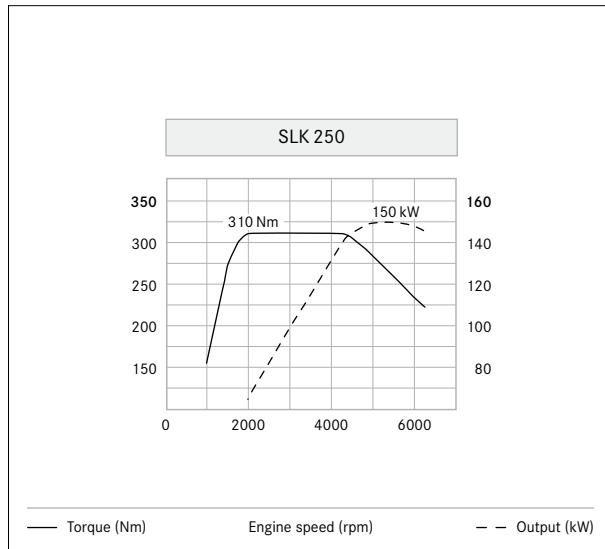

Delivering 150 kW (204 hp) of power, the SLK 250 boasts dynamic performance.

4-cylinder in-line engines. The optimised 4-cylinder 1.8-litre engine with petrol direct injection, two overhead camshafts, variable valve timing and turbocharging delivers outstanding torque and output levels as well as the low consumption and emission figures that we have come to expect. Fuel is used more efficiently by the direct petrol injection system thanks to almost complete combustion, while the variable valve timing allows optimum cylinder charging and thus reduces fuel consumption. These latter points are further aided by the reduced weight and lower internal friction. Two balancer shafts ensure low engine vibration in every engine speed range. Furthermore the sound design gives the car a robust voice that does absolute justice, in acoustic terms, to the vehicle's performance.

The 4-cylinder petrol engine comes with a choice of two power outputs: the SLK 200 offers 135 kW (184 hp) and maximum torque of 270 Nm, while the SLK 250 boasts 150 kW (204 hp) and maximum torque of 310 Nm.

Both models are fitted as standard with the ECO start/stop function, which automatically switches off the engine at traffic lights or in a jam. With the standard-specification ECO display the driver receives information about their own driving style, enabling them to adjust it in order to reduce consumption.

V6 engine. Fuel consumption that is over 20% lower and a fall in CO₂ emissions compared with the previous model – and yet enhanced dynamic performance. All in all, a neat way of summing up the SLK 350. The direct petrol injection system uses spray-guided combustion and high-pressure injection by means of piezo injectors. Maximum output is 225 kW (306 hp), while the peak torque of 370 Nm becomes available at 3500 rpm. Further factors that help to reduce fuel consumption include the standard ECO start/stop function, the air and exhaust system, controlled ancillary assemblies, intelligent alternator management and systematically applied lightweight construction principles. The 6-cylinder unit takes a vigorous approach even low down and impresses with outstanding refinement across the entire engine speed range. The backdrop to this comes courtesy of an impressive soundscape – of the calibre that only a six-cylinder can muster.



The SLK's petrol engines combine comfort and fun at the wheel with sustainability.

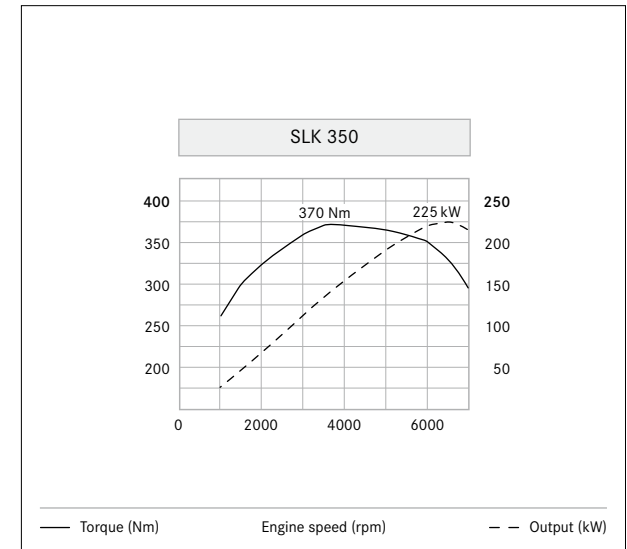

The SLK 350: cutting-edge engine technology with direct injection via piezo injectors.

Diesel engine.

Unusual for a roadster – extraordinary for a diesel: the 4-cylinder in-line engine with an output of 150 kW (204 hp) and a torque of 500 Nm.

4-cylinder in-line engine. The SLK also offers sporty driving enjoyment when fuelled by diesel. Power and speed coupled with exceptionally low fuel consumption and emissions – these are the key attributes of the sophisticated 2.1-litre twin-turbocharged engine. Low fuel consumption and CO₂ emissions make the diesel SLK the most economical roadster in its segment. And all that with the performance of a sports car: acceleration from 0 to 100 km/h takes only 6.5 seconds. Stepping on the gas while already in motion is even more fun – the engine develops its high torque at an engine speed as low as 1600 rpm and, as a result, in-gear acceleration in a class of its own.

This level of performance is made possible by a whole host of intelligent technologies. The fourth-generation common-rail diesel technology boasts increased injection pressure (up to 2000 bar), optimised combustion chambers and high-precision injectors, while optimisation of

the ignition pressure and charging ensures high torque across the entire engine speed range. The necessary refinement comes courtesy of two Lanchester balancer shafts. And optimised alternator management sees to it that the engine's coasting phases are used to great effect. So now it's possible to mention a sports car and a diesel engine in the same breath – without drawing startled glances.

Efficiency is also very much part of the diesel engine's repertoire. As is the case with the two petrol engines, the diesel unit also includes the ECO start/stop function and the ECO display as part of its standard specification. Both help the driver to cut consumption even further.



The diesel unit developing 150 kW (204 hp) offers sporty performance and exceptional refinement with low fuel consumption and low CO₂ emissions.

Transmissions.

Whether it be a manual gearshift or an automatic, an economical or a sporty driving style – the transmissions for the SLK have been optimised in line with the engine with which they are installed. Plus they are intuitive and ergonomic to use.

6-speed manual transmission. The SLK 200, SLK 250 and SLK 250 CDI are paired as standard with a 6-speed manual transmission. It offers impressively short and precise shift travel, while the gear ratios and rear axle ratio are optimally matched to the engine output. A display on the instrument cluster indicates recommended gear changes to further encourage a highly efficient driving style.

7G-TRONIC PLUS. The SLK 350 is teamed up as standard with the optimised 7G-TRONIC PLUS 7-speed automatic transmission – available as an option for the SLK 200, the SLK 250 and the SLK 250 CDI. The 7G-TRONIC PLUS transmission uses the latest generation of torque-converter, which brings with it a more dynamic response, greater durability, low noise levels and reduced fuel consumption. The latter is due also to the standard-specification combination with the ECO start/stop function, which switches off the engine temporarily when standing at

traffic lights or in traffic jams. In addition, the seven forward gears of the 7G-TRONIC PLUS transmission make possible a constant fine-adjustment of the engine speed, short shift times and smooth gearshifting. At the same time driving enjoyment is enhanced: the vehicle accelerates more powerfully and develops greater pulling power. The driver can use a switch in the centre console to pre-select one of the two transmission modes “E” (Economy) and “S” (Sport). In conjunction with the optional steering wheel shift paddles, a third mode is added to these for even faster gearshifting: the “M” (Manual) transmission mode. For dynamic bursts of acceleration also whilst driving in the automatic modes, a manual downshift function allows several gears to be skipped, although the most fuel-efficient gear is always recommended to the driver on the display. The transmission changes back to the most fuel-efficient automatic mode after a set time.



The 7G-TRONIC PLUS: one of over 19 million automatic transmissions produced in a period spanning more than 50 years.

Chassis & suspension.

With its sporty suspension set-up even the standard specification SLK is perfectly prepared for a dynamic driving style – while remaining surprisingly comfortable. With the sports suspension or the driving dynamics package and its selectable suspension and damping set-ups the motoring enjoyment can be enhanced even further.

Sports suspension (option, standard in conjunction with AMG Line and Sports package). A sports suspension with tauter tuning and a body lowered by 10 mm is available as an option. Compared with the standard-specification suspension, here the springs are shorter, the dampers firmer, and anti-roll bars with a larger diameter are installed, which reduces roll movements and increases driving stability.

Dynamic Handling package with Adaptive Damping System ADS (Option). With the optionally available Dynamic Handling package, a touch of the Sport mode button is all it takes to shift the damper setting into sports mode. The electronically regulated damping system adjusts its characteristics continually and steplessly, the damping force being optimally adapted to each indivi-

dual wheel in accordance with the current handling situation and road conditions. This results in a greater handling stability in all speed ranges – as well as significantly increased motoring enjoyment. With the E/S push-button switch the 7G-TRONIC PLUS's gearshifting characteristics can be increased separately: in the S program all the parameters are geared towards best-possible acceleration and swift reaction.

Direct-Steer system (option, standard in conjunction with Dynamic Handling package). The Direct-Steer system comprises two components: firstly the speed-dependent regulation of the power steering control, already familiar from the speed-sensitive steering system. This requires significantly less steering effort when driving slowly, manoeuvring and parking. Secondly there is the rack and

pinion with a variable ratio depending on the steering angle, facilitating a more direct and more spontaneous implementation of the steering movements. This boosts agility and leads to a noticeable reduction in the steering input required in large steering angles, whilst the indirect ratio around the centre position aids straight-line stability.



Integral safety concept.

We are driven by our vision of accident-free driving. With our integral safety concept we are coming closer to achieving this goal – this is a holistic approach which can increase safety in every situation.

As the inventors of the automobile we feel that we have a special responsibility for road safety. That's why we were the first automotive manufacturer to develop an integral safety concept that seamlessly links active and passive safety measures to provide comprehensive protection. The all-encompassing approach is divided into four phases and provides safety solutions for any situation. It includes systems for safe driving, which help prevent danger thanks to their ability to warn and assist the driver in plenty of time. Our unique PRE-SAFE® system comes into play when danger is detected, activating anticipatory measures to protect the car's occupants. If, despite all the preventive measures, a collision remains unavoidable, further technologies can provide protection to suit the circumstances. We've even thought about the time immediately after an accident and developed solutions to prevent a worsening of the situation and facilitate rapid assistance.

A selection of these technologies for the "Safe driving", "In the event of danger", "In an accident" and "After an accident" phases is presented on the pages which follow.

Safe driving: ATTENTION ASSIST (standard). This drowsiness detection system is especially useful on long trips. At speeds of between 80 and 180 km/h, ATTENTION ASSIST can warn the driver as soon as it identifies typical signs of drowsiness or inattention. Several sensors analyse the driver's behaviour and can detect any changes compared with the driver profile individually determined previously.



If ATTENTION ASSIST detects signs of drowsiness, the system recommends a break.

Safe driving: Intelligent Light System (option). This system incorporates five functions: country mode provides enhanced illumination of the offside edge of the road, while motorway mode lights up its full width. Visibility can thus be improved by up to 60 percent. The enhanced fog light function improves visibility in bad weather, while the active light and cornering light functions follow the driver's steering movements and give better lateral illumination over a range of up to 30 metres.



The Intelligent Light System automatically adapts to the prevailing weather, light and driving conditions.

Safe driving: Driving Assistance package (option).

Within the speed range from 0 to 200 km/h, the proximity control system DISTRONIC PLUS can help the driver, at the touch of a button, to maintain the desired distance between the car and the vehicle in front and, if necessary, to initiate braking. Blind Spot Assist helps the driver when turning off or changing lanes. If the system detects another vehicle within the monitored range, a hazard warning triangle lights up in the corresponding exterior

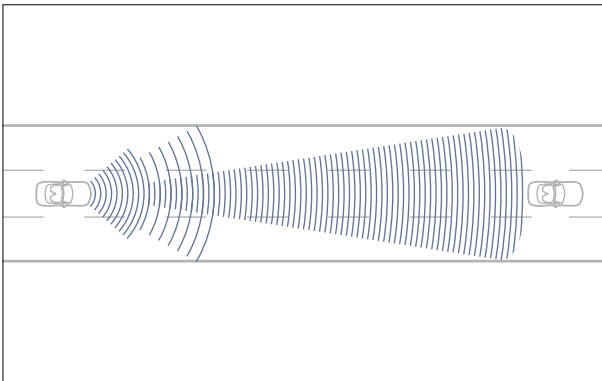

DISTRONIC PLUS supports drivers in automatically keeping their vehicle at a safe distance from the vehicle in front.

mirror. The Lane Keeping Assist feature warns the driver by means of a discreet vibration of the steering wheel as soon as he unintentionally cuts across the lane markings which have been registered by the system, and risks drifting out of lane. The system recognises contrasting colours on the road in front of the vehicle and is thus able to “read” lane markings. In addition, it monitors driving style and the line of the road ahead, analysing any movements that would suggest the vehicle is unintentionally leaving its lane. The system is thus able to differentiate between intentional and unintentional lane changes. The Driving Assistance package is rounded off by the Brake Assist system BAS PLUS and PRE-SAFE® Brake – ensuring a sense of complete safety on every journey. In models from the SLK 350 upwards the high-resolution colour display in the instrument cluster forms part of the standard specification – while in the SLK 200, SLK 250 and SLK 250 CDI it is included as part of the Driving Assistance package.

In the event of danger: PRE-SAFE® Brake and BAS PLUS

(part of the optional Driving Assistance package). PRE-SAFE® Brake provides the driver first with a visual warning, then an audible alert if a risk of collision is detected. During this phase, BAS PLUS calculates the brake pressure that is required to prevent a collision. If the braking force applied by the driver is not sufficient, then the system automatically increases brake pressure in a way that ensures the remaining braking distance is used to the fullest advantage. This means that the driver of the vehicle behind also has a better chance of avoiding a collision. If the driver fails to respond to the signals, PRE-SAFE® Brake intervenes with autonomous partial braking, giving the driver a tangible warning. At the same time, the PRE-SAFE® system triggers other protective measures in preparation for a possible collision. Autonomous emergency braking can then be activated if there is still no reaction from the driver. The result is a significant reduction in impact speed and accident severity.

In the event of danger: PRE-SAFE® system (option). The anticipatory occupant protection system is able to recognise certain critical driving situations in advance and initiate preventive measures. If it recognises that an accident is imminent, the side windows can be closed and the front seat belts tensioned by means of electric motors. Depending on the vehicle specification, the front passenger seat may also move into a position that should prove more favourable in the event of an accident.

In an accident: restraint systems (standard). 3-point seat belts, belt tensioners, belt force limiters and airbags are optimally coordinated with each other at Mercedes-Benz, so as to keep injuries to a minimum wherever possible. The SLK thus includes six airbags as standard, which can help prevent injuries to the driver and passenger in case of a collision: the front airbags, triggered in two stages depending on the impact severity registered, plus sidebags in the seat backrests and headbags in the door supports, which can reduce the loads on the occupants in a side impact or an overturn. If the crash sensors detect an accident, the seat belts are automatically tightened at lightning speed in order to hold the occupants firmly in their seats. The belt force limiter, meanwhile, relaxes the belt during the accident in accordance with the given situation, so as not to place too much strain on the occupant's chest.

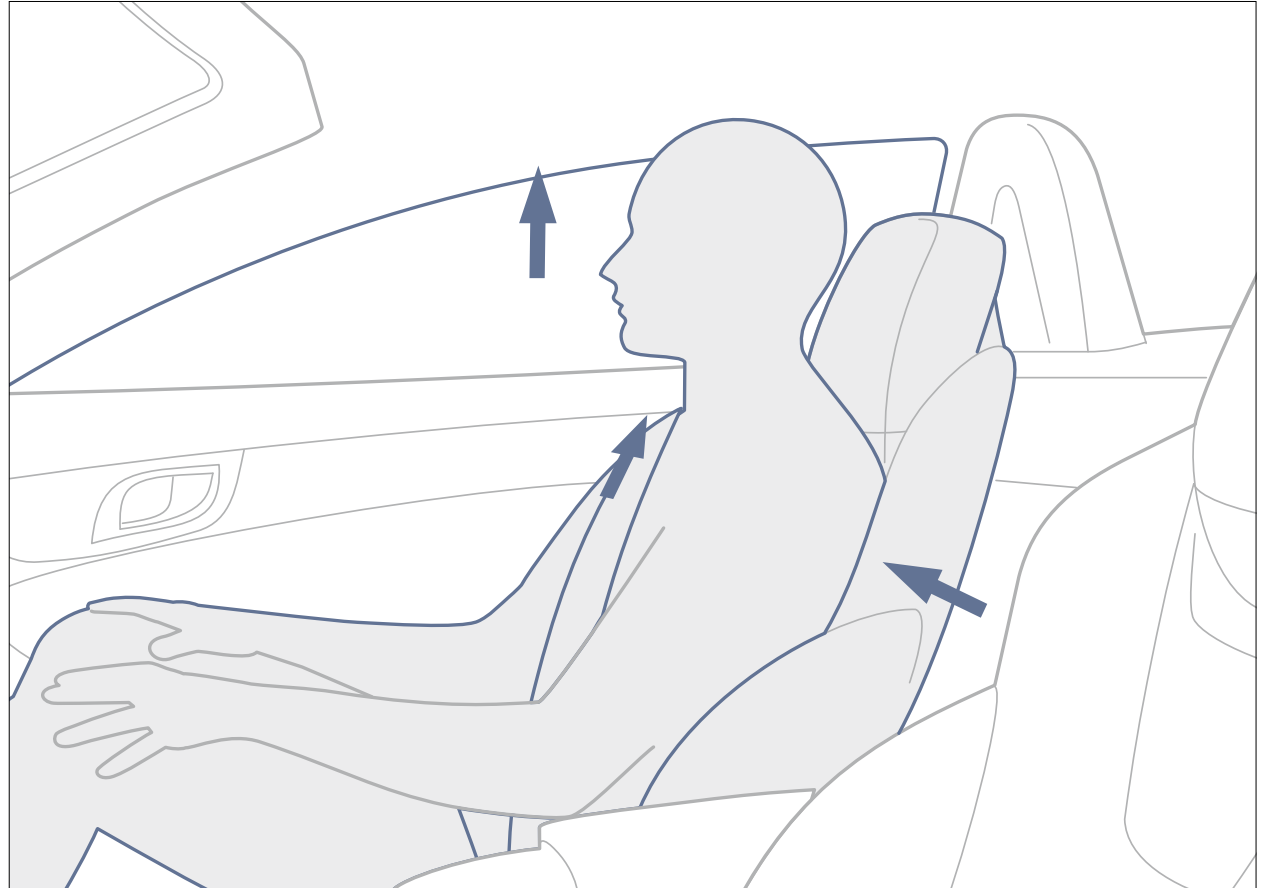

If the PRE-SAFE® system detects that danger is imminent it can, for example, close the side windows, tension the seat belts and move the passenger seat into a more favourable position.

In an accident: NECK-PRO head restraints (standard). The crash-responsive NECK-PRO head restraints can help to improve the protection provided to occupants and play their part in reducing the risk of whiplash injury. In the event of a rear-end collision the head restraints are instantly displaced by around 40 millimetres towards the front and 30 millimetres upwards, thus providing earlier support for the vehicle occupants' heads.

In an accident: Active bonnet (standard). The active bonnet can reduce the risk of injury to pedestrians or

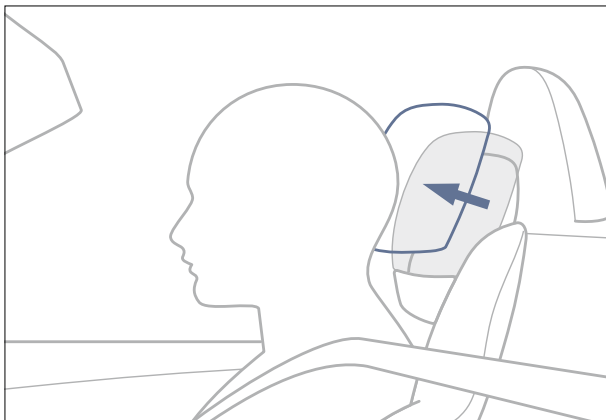

The NECK-PRO head restraints can reduce the risk of whiplash in a rear impact.

cyclists if they are involved in a collision with the bonnet in a speed range between 25 and 55 km/h. To cushion the blow, a pyrotechnical device causes the bonnet to spring up by approx. 8.5 centimetres at the rear.

After an accident: Mercedes-Benz emergency call system¹ (part of COMAND Online). This system is able to send an automatic emergency call using a working mobile phone connected to the vehicle as soon as the restraint system recognises an accident. At the same time it communicates GPS positional data and other

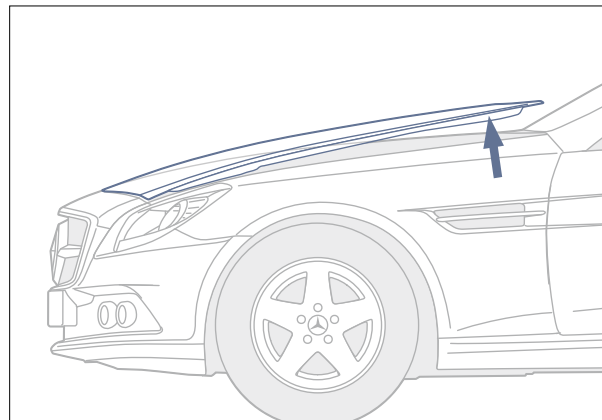

The active bonnet is part of the Mercedes-Benz protection system for more vulnerable road users.

information to the Mercedes-Benz emergency call centre. A voice connection is then established.

Measures after an accident. In order to reduce consequential damage and, where necessary, to support the rescue of the occupants, Mercedes-Benz has developed further measures. These include automatic engine shut-off and activation of the hazard warning lamps and interior emergency illumination. The central locking also unlocks automatically, while a crash joint between the door and wing on each side makes it easier to open the doors after an accident. Mercedes-Benz also provides multilingual Guidelines for Rescue Services, which emergency services worldwide can download from the After-Sales Portal Mercedes-Benz at <https://portal.aftersales.i.daimler.com> or from the Mercedes-Benz website for their country. As you can see, Mercedes-Benz offers well thought-out safety, whatever the situation.

Multimedia systems.

The highest levels of comfort take centre stage. While the optional multimedia system COMAND Online entertains and navigates, all the elements can be easily operated via the Controller, the multifunction steering wheel and the voice-operated control system LINGUATRONIC.

Harman Kardon® Logic 7® surround sound system (option). With 10 loudspeakers and a 10-channel DSP sound amplifier, the sound system has an output of 500 watts, giving you first-class acoustics in both seats. 3D surround sound and speed-sensitive volume control ensure constant listening pleasure. A Dolby Digital 5.1 and DTS listening experience is possible in conjunction with COMAND Online.

COMAND Online (option). The multimedia system boasts a high-resolution 17.8 cm colour display. The system's functions include a radio, speed-sensitive volume control, the Music Register with a 10 GB hard disc and hard-disc navigation – with free European map data updates in the first 3 years. The DVD player can play CDs and MP3 files as well as video and audio DVDs. Access to the internet and various mobile services from Mercedes-Benz is possible via a web-enabled mobile phone. A USB connection, a slot for SD memory cards, a Bluetooth® interface and the optional Media Interface allow connection to external data storage media and a mobile phone. The system can be operated using the central Controller, the buttons on the multifunction steering wheel or by voice control with LINGUATRONIC. In the SLK 350 model and

above, the high-resolution colour display in the instrument cluster comes as standard; for the SLK 200, SLK 250 and SLK 250 CDI it is included within the scope of COMAND Online.

Live Traffic Information¹ (part of COMAND Online). This service allows the reception of up-to-date and precise traffic information in real time for optimised dynamic route guidance and a more accurate estimated time of arrival. The data are transferred via a communications module that

uses an integrated SIM card with data roaming to provide the connection to the internet.

Becker® MAP PILOT (option). The Becker® MAP PILOT takes you conveniently to your destination and has everything you look for in a sophisticated navigation system. Fully integral, it can be operated via the Controller or the Audio 20 CD's display, and in addition can be further individualised by downloading up-to-date map data and additional functions.



The optional COMAND Online system includes a high-resolution 17.8 cm colour display providing a clear overview of all the system functions.



The Becker® MAP PILOT is fully integral and can be operated via the Audio 20 CD.

¹ 3 years of free use, available in 12 countries.

Assistance systems.

There are numerous assistance systems to reduce the driver's workload, both on the open road and when performing difficult manoeuvres.

Speed Limit Assist (option, part of COMAND Online).

A windscreen-mounted camera that permanently scans the car's surroundings is able to recognise speed limit signs and indicate the detected maximum speed to the driver via the display. The driver can therefore check the prevailing speed limit at any time. This added convenience is of particular benefit on routes with variable speed limits or in roadworks.



The information from Speed Limit Assist is shown both in the instrument cluster and in the COMAND Online central display.

PARKTRONIC, incl. Parking Guidance (option).

Parking Guidance can help the driver when parking and also when looking for a parking space: ultrasonic sensors at the side of the front bumper automatically measure the length of parking spaces parallel to the car if it drives past at a speed of 30 km/h or less. If a suitable space has been found and reverse gear is engaged, the Parking Guidance starts. It gives the driver visual and audible directions via the instrument cluster regarding the correct steering angle as well as the turn-in and turn-back points.



Parking Guidance indicates suitable parking spaces to the driver and provides parking directions.

The PARKTRONIC electronic parking aid uses ten sensors to monitor the front and rear of the vehicle during manoeuvring and warns the driver if a potential collision is detected. If the system detects an obstacle, a visual signal appears. As soon as the distance is less than approximately 35 cm, a short warning sound is emitted as well. If the vehicle gets even closer, a continuous signal is heard. In this way PARKTRONIC makes parking easier, even when space is limited. If the vehicle is not straight after the first reversing manoeuvre, the system will also help the driver with the parking manoeuvres still needed.

Open-air comfort.

Some of the SLK's features can make open-top motoring even more fun – at any time of year and in virtually any weather.

AIRSCARF (option). The neck-level heating developed by Mercedes-Benz extends the open-air season. At the touch of a button, air is wrapped around the shoulders and neck of the driver and passenger like a warming scarf. In order to achieve this effect the system draws in cold air, which it then warms and releases back through discreetly positioned vents in the head restraints.

Sun-reflecting leather (standard in conjunction with leather, nappa leather and Exclusive nappa leather, with the exception of designo leather). As an optional extra the SLK's seats are available with a coating which reflects heat. This prevents the seats from heating up in intense sunlight – so bringing extra comfort, particularly when the vehicle is open.

AIRGUIDE (option). The draught-stop system AIRGUIDE minimises draughts and wind noise when driving with the roof down – and thus tangibly enhances comfort. The transparent and swivelling plastic discs on the back of the roll-over bars can be individually adjusted for the driver and passenger. They divert the windflow and prevent the turbulence which usually occurs.



AIRSCARF delivers warm air to ensure perfect open-top motoring pleasure even in cool weather.



The draught-stop system AIRGUIDE minimises draughts in the interior of the open vehicle.

Roof and space.

Comfort standards are redefined in the SLK. On the one hand, the panoramic vario-roof with MAGIC SKY CONTROL creates an impression of space and airiness even in the closed vehicle. On the other, all the roof variants offer plenty of room for luggage even when the car is open.

Vario-roof (standard). The electrohydraulically operated vario-roof makes the SLK a weatherproof car for all seasons. At the touch of a button the vehicle is transformed from a coupé to an open roadster in less than 20 seconds – and vice versa. And even with the roof open you can still make good use of the boot.



The roadster's boot offers plenty of stowage space whether the roof is open or closed.

Panoramic vario-roof (option). A panoramic vario-roof is available for the SLK as an optional extra. It lets a lot of light in, making the interior seem even lighter and roomier. The occupants can thus savour the pleasant atmosphere and that special open-top motoring feel even when the roof is closed.



The panoramic vario-roof offers virtually total overhead visibility when closed, too.

Panoramic vario-roof with MAGIC SKY CONTROL (option). The glass roof on the SLK can change its light and energy transmission capability in seconds, just at the push of a button. In its transparent state it affords a view of the sky, even when the vehicle is closed. When darkened it protects against over-intense sunlight.



MAGIC SKY CONTROL enables adjustment of the optional panoramic vario-roof's transparency.

Climate control and light.

A pleasant interior climate increases motoring pleasure and driver-fitness safety, so in the SLK the temperature can be individually regulated, and the interior stylishly showcased in darkness.

Ambient lighting (option). The concept behind this showcasing of the car in the colour solar red is to lend sporty emphasis to the interior design in darkness, helped by the direct illumination of the centre console and door armrests, and the indirect illumination of the door centre panels. Immediately upon opening the door, the driver is welcomed by the illuminated vehicle. Once the door has been closed, the light is automatically dimmed – there

are five possible brightness levels that can be set. As an option the ambient lighting can include the Interior Light package as an attractive addition.

Air conditioning (standard). It automatically controls the temperature in the vehicle interior. The convenient air recirculation with automatic window closing is part of the specification, as is the residual engine heat utilisation.

A fine-particle activated charcoal filter keeps dust, soot and pollen at bay and reduces odours and pollutants in the air.

THERMOTRONIC (option). The automatic climate control THERMOTRONIC has separate temperature controls for each side of the interior, allowing the driver and passenger to travel in comfort at the temperature of their choice. At the touch of a button the 2-zone system works fully automatically. THERMOTRONIC holds the temperature constant at the desired level and also takes exterior factors such as sunlight, air quality and humidity into account via its sensors. This means that there is always a pleasant atmosphere in the SLK, boosting comfort on the one hand and the driver's concentration on the other, thus enhancing the safety of both occupants.



The optional ambient lighting gives the interior a particularly sporty aura.

Seats.

The sporty seats in the SLK meet the very latest requirements in terms of ergonomic design, comfort and safety.

The SLK's sports seats offer excellent lateral support and tangibly stabilise the bodies of the driver and passenger – even at high speeds on winding roads. They also offer exceptional comfort on longer journeys. With their head restraints integrated in the backrests, the seats are both a safety element and a design feature. They emphasise the high quality of the vehicle design, forming a sporty, stylish focus – particularly when you look into the open vehicle.

In the base version in fabric the upholstery is entirely black. As an option it is possible to have your SLK fitted with seats in embossed leather in black, sahara beige or crystal grey or, alternatively, in nappa leather in black, bengal red or mocha/nut brown. With the AMG Line, the leather is also adorned with red topstitching and the specific vertical piping design in the seat surface.

Memory function (option). The Memory function can be used to save preferred settings for up to three people. The seat and backrest position, steering wheel position and the exterior mirror position on the driver's and passenger side can be stored and called up again at just the touch of a button.



The comfortable seats combine ergonomics with safety and sportiness.

SLK 55 AMG exterior.

At Mercedes-Benz, three letters stand for the ultimate in sporty driving dynamics: AMG. Just to look at, the SLK 55 AMG appears to embody the united qualities of leading-edge technology, exclusivity and dynamism – and it delivers on the promise with every ride. → www.mercedes-amg.com

The SLK 55 AMG – the epitome of a roadster with the heart of a top athlete. Evidence of the power harnessed by its AMG engine is hinted at on the outside by the V8 lettering on the front wings. A small detail that marks the prelude to a wealth of AMG-specific design features.



The sporty tail end is drawn to a powerful conclusion by the AMG-design twin tailpipes and spoiler lip.

The car is encased within the AMG front and rear aprons as well as the side sill panels, all of which exude a distinct feeling of power. This outfit is exclusively rounded off by a lower cross strut, painted in high-gloss black, the simulated side air outlets at the front and the diffuser look at the rear. What's more, the radiator grille louvre painted in



Exceptionally expressive: the 5-spoke AMG light-alloy wheels.

high-gloss black lends the SLK 55 AMG an even more powerful aura. So connoisseurs will be left in no doubt as to the car's AMG genealogy.

Further highlights include the AMG daytime running lamps as well as the darkened headlamps and tail lights. Furthermore ensuring that the SLK 55 AMG always leaves a lasting impression is an exhaust system featuring two chrome-plated, oval twin tailpipes.

The car's appearance is further enhanced by 45.7 cm 5-spoke AMG light-alloy wheels painted titanium grey with a high sheen finish, paired with 235/40 front and 255/35 rear tyres. Optional extras from the AMG Performance Studio can transform the SLK 55 AMG into the AMG Mercedes of your dreams. With AMG you, too, get to choose what high-performance sport looks like.



SLK 55 AMG interior.

Few things can match the dynamism of the exterior. But the interior succeeds in doing so. With high-quality materials to create luxury and, above all, sportiness à la AMG.

Driving enjoyment begins with the way you sit – one reason why a ride in the SLK 55 AMG is so enjoyable. For the AMG sports seats offer optimum support when accelerating or negotiating hairpins at speed. In this case the vehicle is controlled via the AMG Performance



Key data displayed at all times and full control of the car – thanks to the instrument cluster and the AMG performance steering wheel.

steering wheel with its aluminium shift paddles, which delights in passing every steering command it receives on to the Direct-Steer system. Both the vehicle's road speed and its engine speed can be monitored on the AMG instrument cluster, which includes the RACETIMER function, while the optional AMG-specific analogue clock



The optional AMG analogue clock from IWC provides the perfect finishing touch in the sporty and luxurious interior.

in IWC design will remind you of the actual time, so easily forgotten when enjoying the ride in an SLK 55 AMG.

Precise craftsmanship, a desire for perfection and high-quality materials abound throughout the car's interior. The result: whoever takes their seat here is bound to feel ready for whatever adventures lie ahead. Having already been greeted by AMG door sill panels when opening the door.

Fine nappa leather in a choice of three colours is optionally available as an alternative to the standard ARTICO man-made leather/fabric appointments in black.



SLK 55 AMG technical features.

The heart of a sports car is its engine. In the SLK 55 AMG, the AMG 5.5-litre V8 engine beats impressively in tune with the AMG SPEEDSHIFT PLUS 7G-TRONIC automatic transmission: offering an output of 310 kW (421 hp), a torque of 540 Nm and the best fuel consumption figures.

The SLK 55 AMG owes its outstanding driving dynamics to a host of willing helpers. The Direct-Steer system, for instance, makes for precise steering manoeuvres, while ESP® Dynamic Cornering Assist allows controlled cornering at the critical limits. In this case, the inner rear wheel is braked specifically for a brief period, allowing the car to bank into the bend, thus noticeably enhancing both agility and active safety. The AMG sports suspension, equipped with AMG-specific springs, dampers and torsion bar,

also helps to achieve this effect. To tame the engine's incredible power, the SLK 55 AMG is fitted with the AMG high-performance braking system. The front brakes feature 4-piston fixed callipers with internally ventilated and perforated 360 x 36 mm discs for short stopping distances, while the rear brakes have 1-piston floating callipers with 330 x 22 mm discs. Because driving enjoyment is also about stopping at the right moment.

AMG 5.5-litre V8 engine. Its performance figures set the heart racing: 310 kW (421 hp) and a torque of 540 Nm available even at low engine speeds. Its fuel consumption, meanwhile, pays homage to reason – the 5.5-litre V8 unit is the most efficient high-performance engine in its segment. This is made possible by the Controlled Efficiency stop/start function and the AMG Cylinder Management system, which switches off four cylinders when these are not needed. But there is one thing that hasn't decreased in the AMG engine: the sonorous V8 engine sound.

AMG SPEEDSHIFT PLUS 7G-TRONIC automatic transmission with double-declutching function. The AMG transmission sees to it that the engine power is sent to the road as effectively as possible. Gear changes are exceptionally rapid, while traction is practically uninterrupted. The double declutching function makes gear-changing faster still and reduces load changes when cornering, while three drive programs offer all the driving enjoyment you could wish for – Sport, Comfort or Manual.

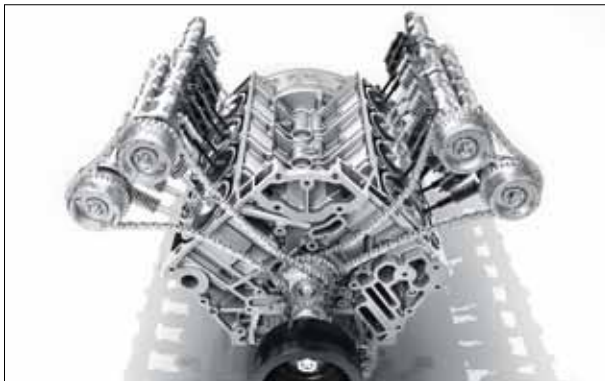

The AMG 5.5-litre V8 engine with AMG Cylinder Management impresses with its high performance and the lowest consumption figures in its segment.



With max. 310 kW (421 hp) and 540 Nm plus the AMG SPEEDSHIFT PLUS 7G-TRONIC, the unit ensures superb propulsive power.

AMG Performance Studio.

Although an SLK 55 AMG is already unique, it can be further individualised in the Performance Studio. Various equipment options can be selected to bring the sporty, expressive appearance and outstanding performance even further to the fore.



The SLK 55 AMG can be further individualised in the AMG Performance Studio.

The AMG Performance Studio is the crowning glory of every AMG Mercedes. Various possibilities for fitting out the SLK 55 AMG make it an even sportier vehicle in terms of both performance and appearance. Take the Handling package, for instance: this comprises compound brake discs at the front, a performance suspension, a rear-axle limited-slip differential for optimal roadholding and the Performance steering wheel with Alcantara® in the grip area.

Equally expressive are the 45.7 cm 10-spoke AMG light-alloy wheels – painted in either titanium grey with a high-sheen finish or matt black with a high-sheen rim flange. Those wishing to drive the car at up to 280 km/h should also opt for the Driver's package (includes accompanied participation in driver training at the AMG Driving Academy).

The AMG Performance Studio in Affalterbach can also meet other customer requests – including the production of one-off models. As an option, you can collect your vehicle yourself in Affalterbach.

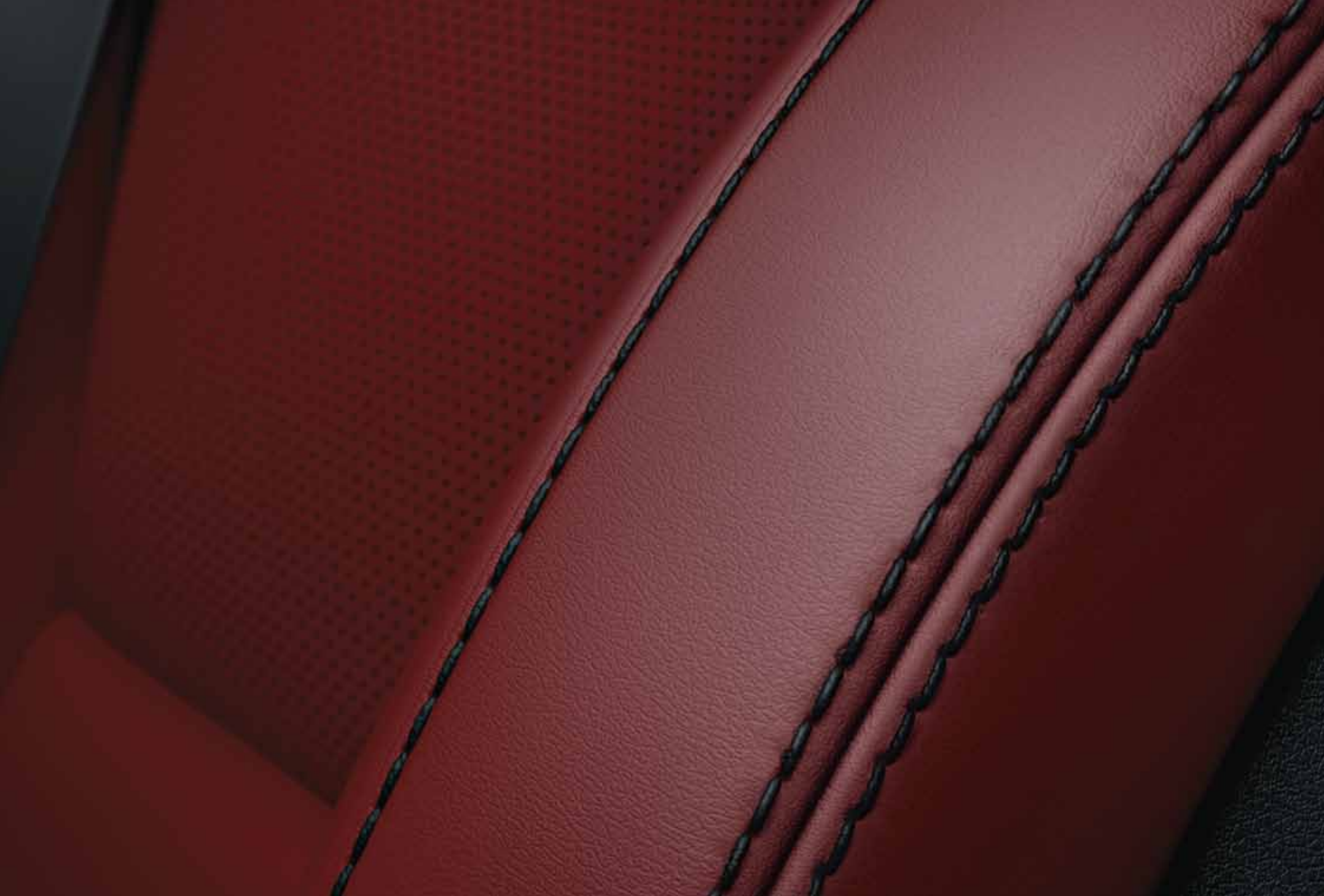

Upholstery and trim.



The black colour scheme sports black seats which are available either in fabric or, as an option, in leather, nappa leather or Exclusive nappa leather. The grey contrasting topstitching adds an eye-catching note. The centre console is in light longitudinal-grain aluminium as standard, the metallic surfaces in fine silver chrome.



001



201

801
501



H76



736



731

Black

- 001 Fabric
- 201 Leather (option)
- 801 Nappa leather (option)
- 501 Exclusive nappa leather (option)

Trim

- H76 Light longitudinal-grain aluminium
 - 736 High-gloss black ash wood (option)
 - 731 High-gloss brown burr walnut wood (option)
-



The sahara beige colour scheme sports sahara beige seats which are available in embossed leather. Black contrasting topstitching adds an eye-catching note. The centre console is in light longitudinal-grain aluminium as standard, the metallic surfaces are in fine silver chrome.



205



H76



736



731

Sahara beige (option)

205 Leather

Trim

H76 Light longitudinal-grain aluminium

736 High-gloss black ash wood (option)

731 High-gloss brown burr walnut wood (option)



The crystal grey colour scheme sports crystal grey seats which are available in embossed leather. Black contrasting topstitching adds an eye-catching note. The centre console is in light longitudinal-grain aluminium as standard, the metallic surfaces are in fine silver chrome.



208



H76



736



731

Crystal grey (option)

208 Leather

Trim

H76 Light longitudinal-grain aluminium

736 High-gloss black ash wood (option)

731 High-gloss brown burr walnut wood (option)



The bengal red colour scheme sports bengal red seats which are available in nappa leather or Exclusive nappa leather. Black contrasting topstitching adds an eye-catching note. The centre console is in light longitudinal-grain aluminium as standard, the metallic surfaces are in fine silver chrome.



807
507



H76



736



731

Bengal red (option)

807 Nappa leather

507 Exclusive nappa leather

Trim

H76 Light longitudinal-grain aluminium

736 High-gloss black ash wood (option)

731 High-gloss brown burr walnut wood (option)



The nut brown colour scheme sports two-tone seats which are available in nappa leather or Exclusive nappa leather. The seat surfaces are in nut brown, the side bolsters in mocha brown. Saffron-coloured contrasting topstitching adds an eye-catching note. The centre console is in light longitudinal-grain aluminium as standard, the metallic surfaces are in fine silver chrome.



854

554



H76



736



731

Nut brown (option)

854 Nappa leather

554 Exclusive nappa leather

Trim

H76 Light longitudinal-grain aluminium

736 High-gloss black ash wood (option)

731 High-gloss brown burr walnut wood (option)

AMG Line.

The SLK's sporty look is given the perfect finishing touch with the optional AMG Line.

The optionally available AMG Line lends the SLK a dynamic look. This starts on the exterior, with the dynamic AMG front apron with LED daytime running lamps and the headlamps with dark edging, plus the powerful side sill panels,



The distinctive rear apron – part of the AMG Line.

and continues round to the striking rear apron and the dark-tinted tail lights. High-shine AMG light-alloy wheels with 225/40 R 18 front and 245/35 R 18 rear tyres complete the look. The sports suspension (including



AMG 5-spoke light-alloy wheels with a high-shine finish.

lowering by 10 mm) tangibly enhances the lateral dynamics. For the 4-cylinder in-line models, the larger brakes with perforated discs and “Mercedes-Benz” lettering on the callipers ensure even more effective deceleration. For the SLK 200 and SLK 250, a sportier engine sound provides the AMG Line's crowning glory.



AMG Line.

Exclusivity meets sportiness in the SLK with the AMG Line.

The AMG Line's interior concept also impresses with its sporty details. The instrument cluster with its "Chequered Flag" design adds to the dynamic feel, as does the steering wheel, which is a comfortable fit in your hands,

with shift paddles in conjunction with 7G-TRONIC PLUS, and perforated leather and red topstitching. The red topstitching also adorns the seats with their specific longitudinal piping, the armrests in the doors and centre

console as well as the shift lever gaiter, adding characteristic touches, as do the red seat belts. In addition to all this, AMG floor mats are part of the package's exclusive specification.



The perforated multifunction sports steering wheel with red topstitching.



The instrument cluster with its "Chequered Flag" design.



Floor mats with "AMG" lettering.





designo.

The exclusive designo paintwork, leather appointments and trim stand for individuality. → www.mercedes-benz.com/designo

Maximum individuality for the SLK comes courtesy of designo. The carefully selected materials are processed with unerring craftsmanship and precision to create an unmistakable masterpiece. The single- or two-tone designo leather appointments with the characteristic design for the seats and the door centre panels are available in a selection of 11 exclusive colour shades. Coordinating designo trim, high-gloss black piano lacquer or sporty AMG carbon fibre offer a wealth of individualisation options.

The designo range for the interior is rounded off by the exclusive designo windscreen frame in DINAMICA microfibre in anthracite, the designo steering wheel in two-tone leather and red or silver-coloured seat belts. The designo selection also includes five unique paintwork variants, two of which are matt finishes.



Sporty AMG carbon-fibre trim.

Standard equipment | Selection.



ATTENTION ASSIST.



High-res display in instrument cluster (standard on SLK 350 and above).¹



Clear-lens headlamps and daytime running lamps.



Air conditioning.

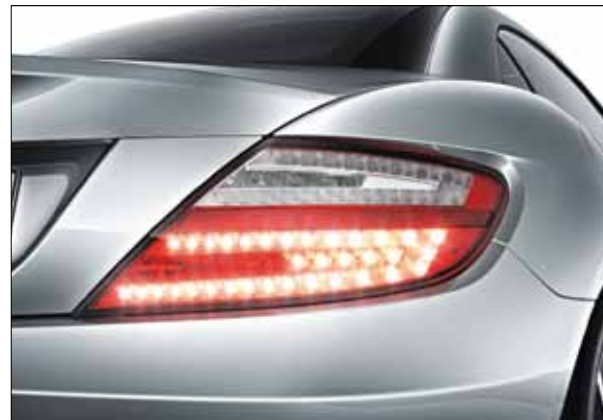

LED tail lights.



Vario-roof.

¹ As optional extra included within scope of COMAND Online or Driving Assistance package.



Audio 20 CD.



Ergonomic sports seats.



Multifunction sports steering wheel with a flattened bottom section.



USB interface in the centre console.



Door sill panel in stainless steel.



Roof control unit and Controller.

Optional extras | Selection.



Panoramic vario-roof with MAGIC SKY CONTROL.



Becker® MAP PILOT for Audio 20 CD.



Intelligent Light System with LED daytime running lamps.



Ambient lighting.



Exclusive nappa leather package.



Harman Kardon® Logic 7® surround sound system.



AIRGUIDE and roll-over bars with anodised aluminium insert.



AIRSCARF neck-level heating.



COMAND Online multimedia system.



Electric seat adjustment with Memory function.



KEYLESS-GO.



Sports package.

Wheels.



10-spoke light-alloy wheels with 205/55 R 16 tyres (standard for SLK 200, Code 39R).



9-spoke light-alloy wheels with 205/55 R 16¹ tyres; 205/55 R 16 at front and 225/50 R 16 at rear (standard for SLK 250 CDI, Code R49).



5-spoke light-alloy wheels with 225/45 R 17 front and 245/40 R 17 rear tyres (standard for SLK 250, Code 37R).



10-spoke light-alloy wheels, painted palladium silver, high-shine, with 225/45 R 17 front and 245/40 R 17 rear tyres (option, Code R93).



5-spoke light-alloy wheels with 205/55 R 16 front and 225/50 R 16 rear tyres (Code R19).



10-spoke light-alloy wheels with 225/45 R 17 front and 245/40 R 17 rear tyres (standard for SLK 350, Code R35).



Multi-spoke light-alloy wheels with 225/45 R 17 front and 245/40 R 17 rear tyres (option, Code R81).



5-twin-spoke light-alloy wheels with 225/40 R 18 front and 255/35 R 18 rear tyres, exclusively for Sports package (option, Code R70).

¹ Option at no extra charge for SLK 200 and SLK 250, Code R12. ² Supplied without tyres.



5-twin-spoke light-alloy wheels, painted palladium silver, high-sheen, with 225/40 R 18 front and 245/35 R 18 rear tyres (option, Code 22R).



5-spoke AMG light-alloy wheels, high-sheen, with 225/40 R 18 front and 245/35 R 18 rear tyres (AMG Line, Code 782).



10-spoke AMG light-alloy wheels, painted titanium grey, high-sheen, with 235/40 R 18 front and 255/35 R 18 rear tyres (option, Code 796).



5-spoke AMG light-alloy wheels², painted black, high-sheen, with 225/40 R 18 front and 245/35 R 18 rear tyres.



5-spoke light-alloy wheel with 225/40 R 18 front and 245/35 R 18 rear tyres (option, Code R32). Also available in tremolite grey (option, Code R36).



5-spoke AMG light-alloy wheels, painted titanium grey, high-sheen, 235/40 R 18 front and 255/35 R 18 rear tyres (standard for SLK 55 AMG, Code 790).



10-spoke AMG light-alloy wheels, painted matt black, high-sheen rim flange, with 235/40 R 18 front and 255/35 R 18 rear tyres (option, Code 760).



6-spoke light-alloy wheels², painted titanium silver, with 205/55 R 16 tyres (genuine accessories).



Genuine Accessories.

The Mercedes-Benz Genuine Accessories range offers everything you need to make the SLK even sportier: a whole host of accessory products optimally tailored to the vehicle. → www.mercedes-benz-accessories.com

With the Mercedes-Benz Genuine Accessories range the character of your vehicle can be highlighted even more: with the distinctive Mercedes-Benz Sport Equipment rear spoiler or the chromed fin attachments for the bonnet, for instance.

In addition to visual enhancements, there is also a range of practical accessories with for individualising your SLK. These include, for example, a shallow boot tub with a slightly raised edge, which fits the load area perfectly and also has a ribbed structure to prevent the load from slipping.

The Genuine Accessories range offers you a selection of high-quality, practical products.



Fin attachments for the bonnet, chromed.

To find out more, please see our accessories brochure or consult your authorised Mercedes-Benz dealer, who will be pleased to advise you.



Boot tub, shallow.



More than simply a star. A whole universe.

The range of **services from Mercedes-Benz**. Every Mercedes brings with it as a standard feature a reassuring feeling of safety on the road. But if you ever do need help, we're here for you around the clock. You can reach us from anywhere in Europe on the toll-free number 00800 1 777 7777¹ (or alternatively direct through Mercedes-Benz Contact²).

Ensuring that you can keep moving in the event of a technical breakdown, accident, vandalism or even misfuelling, the **Mercedes-Benz mobility package Mobilo³** is included as part of the standard specification. It covers the cost of local assistance, for example for towing your car away or for a replacement vehicle – and will do so in more than 40 countries across Europe for up to 30 years³. Furthermore, for the first four years following initial registration of the vehicle, Mobilo offers special mobility services in the case of workshop visits involving warranty or goodwill situations.

Avoid unexpected workshop costs⁴: a **Mercedes-Benz ServiceContract** covers unforeseeable repairs, maintenance or wear parts, depending on the specific contract. Your local Mercedes-Benz dealer will be pleased to provide information about available service contracts and terms and conditions.

Mercedes-Benz Financial Services. Drive a Mercedes-Benz and remain flexible when it comes to payment: our attractive leasing and finance products make this possible – matched to your requirements and needs. We will also be happy to offer you a range of detailed insurance proposals. Just speak to your Mercedes-Benz dealer, who will be happy to provide information about our current range of financial services, terms and conditions.

¹ Alternatively: +49 69 95 30 72 77. Calls to a landline are chargeable. ² Calls from a mobile phone to a landline are chargeable. ³ When it expires, (four years after initial registration) Mobilo can be extended to up to 30 years from one service to the next by your authorised Mercedes-Benz service partner. ⁴ Mercedes-Benz ServiceContract terms and conditions apply.

Enjoy the digital experience of Mercedes-Benz –

wherever you happen to be. Thanks to a range of offers optimised for smartphones and tablet computers, you can immerse yourself in the world of Mercedes-Benz even while on the move.

Insights into the full product range, a varied programme of entertainment and direct contact to a wide variety of services await you. Take an interactive tour with the **Interactive Owner's Manual**, for example, to get to know your dream car better. Experience the various functions in detail, take a close-up look at what's going on inside or explore the benefits of the particular model on your national Mercedes-Benz website.

With the **"Mercedes-Benz Guides"** app you can also explore the highlights of the various vehicles off-line. The app is available free of charge from the Apple® iTunes® Store (iOS) or the Google Play Store (Android).

Incidentally, our TV and magazine media are also available to watch and read digitally. Explore the whole brand world for yourself at www.mercedes-benz.com. Just click to take a look.

The **fascination of Mercedes-Benz**. A car whose name brings a gleam to the eyes of people all over the world, one that has featured in many a movie and been sung about in international hits, is surely far more than just a car. How did it come to this?

Discover just what has been moving the world for more than 125 years and take a fascinating journey through time as well as through the history of the automobile, in the **Mercedes-Benz Museum**. More than 1500 exhibits over a display area of 16,500 square metres demonstrate the unique heritage and innovative power of the inventor of the automobile, among them one-off models such as the oldest Mercedes still in existence, built in 1902, or the legendary "Gullwing" cars. Welcome to a place of innovation: www.mercedes-benz-classic.com/museum

What would the history of Mercedes-Benz be like without **motorsport**? What would motorsport be without Mercedes-Benz? The first vehicle ever to win an automobile race was powered by a Daimler engine. The first Mercedes was a racing car. The Silver Arrows – a true legend. Out of this glorious past has grown an exciting present: the MERCEDES AMG PETRONAS Formula 1 team and the DTM Mercedes AMG C-Coupés fight it out weekend after weekend for points and victory.



Dimensions.

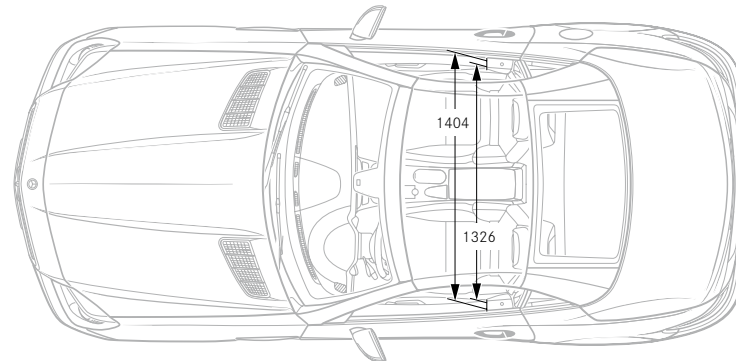
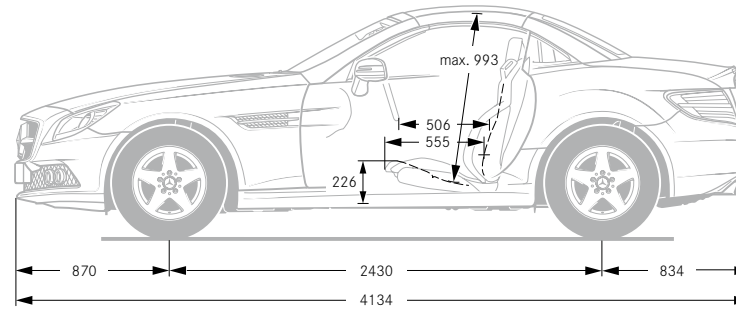
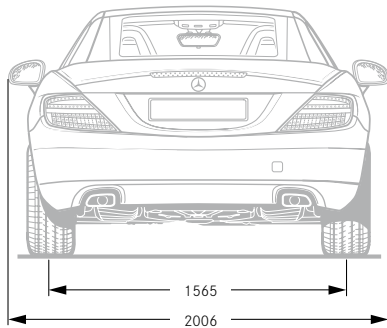
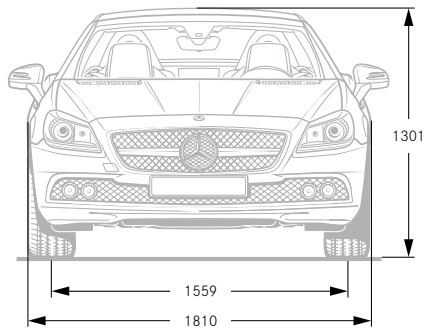

Paintwork.

The paint system developed by Mercedes-Benz includes one of the best clear coats on the automotive market and is a key factor behind the car's excellent value retention. Its secret is the exceptionally thick molecular structure, which makes the metallic or non-metallic clear coat more resistant and produces a longer lasting and visibly more intensive shine.

Non-metallic paints (standard)

- 040 black
 - 149 polar white
 - 590 fire opal
-

Metallic paints (option)

- 197 obsidian black
 - 755 tenorite grey
 - 775 iridium silver
 - 792 palladium silver
 - 890 cavansite blue
 - 963 indium grey
 - 988 diamond silver
-

designo paint finishes (option)

- 799 designo diamond white bright
 - 996 designo hyacinth red metallic
-

Details of further individual designo paint finishes available from your authorised Mercedes-Benz dealer.

Technical data.

| Petrol engines | SLK 200 | SLK 250 | SLK 350 | SLK 55 AMG |
|--|-------------------|-------------------|----------------------|------------------------|
| No. of cylinders/arrangement | 4/in-line | 4/in-line | 6/V | 8/V |
| Total displacement in cc ³ | 1796 | 1796 | 3498 | 5461 |
| Rated output ¹ in kW (hp) at rpm | 135 (184)/5250 | 150 (204)/5500 | 225 (306)/6500 | 310 (421)/6800 |
| Rated torque ¹ in Nm at rpm | 270/1800-4600 | 310/2000-4300 | 370/3500-5250 | 540/4500 |
| Acceleration from 0 to 100 km/h in s | 7.3 [7.0] | 6.5 [6.6] | - [5.6] | - [4.6] |
| Top speed, approx. in km/h | 240 [237] | 244 [243] | - [250] ⁵ | - [250] ^{5,6} |
| Fuel consumption ² in l/100 km | | | | |
| Urban | 9.3-8.9 [8.6-8.3] | 9.8-9.5 [8.7-8.4] | - [9.9] | - [12.0] |
| Extra-urban | 5.3-5.0 [5.3-4.9] | 5.8-5.3 [5.4-5.0] | - [5.5] | - [6.2] |
| Combined | 6.8-6.4 [6.5-6.1] | 7.3-6.9 [6.6-6.2] | - [7.1] | - [8.4] |
| CO ₂ emissions ² in g/km, combined | 158-149 [151-142] | 169-160 [153-144] | - [167] | - [195] |
| Efficiency class | C [C] | D [C] | - [D] | - [E] |
| Emission class ³ | Euro 5 | Euro 5 | Euro 5 | Euro 6 |
| Tank capacity in l/incl. approx. reserve | 60/8.0 | 60/8.0 | 60/8.0 | 70/9.0 |
| Boot capacity in l | | | | |
| With the roof closed | 335 | 335 | 335 | 335 |
| With the roof open | 225 | 225 | 225 | 225 |
| Turning circle diameter in m | 10.52 | 10.52 | 10.52 | 10.53 |
| Kerb weight ⁴ in kg | 1435 [1470] | 1475 [1500] | - [1540] | - [1610] |
| Perm. GVW in kg | 1750 [1785] | 1790 [1815] | - [1855] | - [1910] |

Figures in square brackets refer to engines with an automatic transmission.

¹ Details in accordance with the currently valid version of Directive 80/1269/EEC. ² The stated values were determined according to the prescribed measuring method (currently valid version of Regulation [EC] 715/2007). The figures are not based on an individual vehicle and do not constitute part of the product offer; they are provided solely for the purposes of comparison between different vehicle models. ³ Figures only valid within the European Union. ⁴ Figures in accordance with Directive 92/21/EC, version 95/48/EC (kerb weight with fuel tank 90% full, driver, 68 kg, and luggage, 7 kg) for standard-specification vehicles. Optional extras and accessories will generally increase this figure and reduce the payload capacity accordingly. ⁵ Electronically limited. ⁶ 280 km/h with AMG Driver's package. Further technical data can be found at www.mercedes-benz.com

| Diesel engine | SLK 250 CDI |
|--|--------------------|
| No. of cylinders/arrangement | 4/in-line |
| Total displacement in cc ³ | 2143 |
| Rated output ¹ in kW (hp) at rpm | 150 (204)/3800 |
| Rated torque ¹ in Nm at rpm | 500/1600-1800 |
| Acceleration from 0 to 100 km/h in s | 6.5 [6.7] |
| Top speed, approx. in km/h | 244 [243] |
| Fuel consumption ² in l/100 km | |
| Urban | 6.4-6.2 [6.2-6.1] |
| Extra-urban | 4.1-4.0 [4.3-4.1] |
| Combined | 5.0-4.8 [5.0-4.9] |
| CO ₂ emissions ² in g/km, combined | 129-124 [132-128] |
| Efficiency class | A [A] |
| Emission class ³ | Euro 5 |
| Tank capacity in l/incl. approx. reserve | 60/8.0 |
| Boot capacity in l | |
| With the roof closed | 335 |
| With the roof open | 225 |
| Turning circle diameter in m | 10.52 |
| Kerb weight ⁴ in kg | 1570 [1590] |
| Perm. GVW in kg | 1885 [1905] |

Non-metallic paints

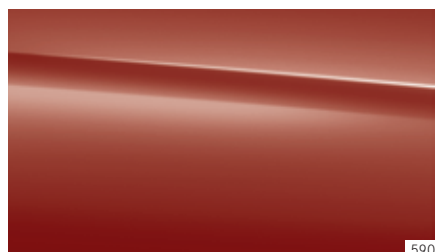
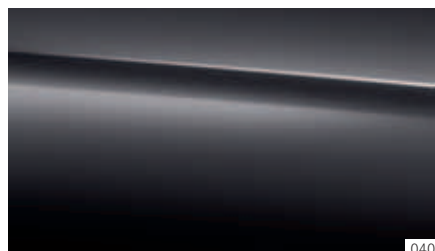

Metallic paints

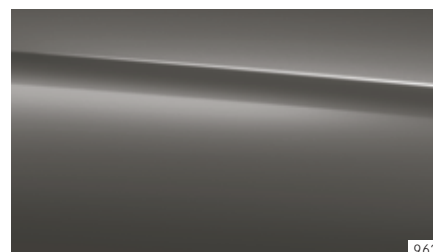
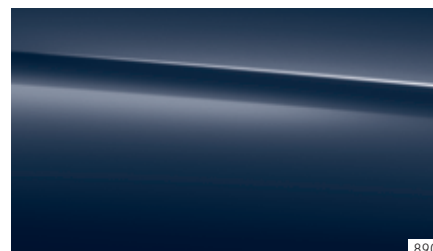
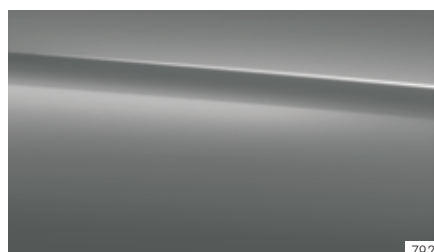
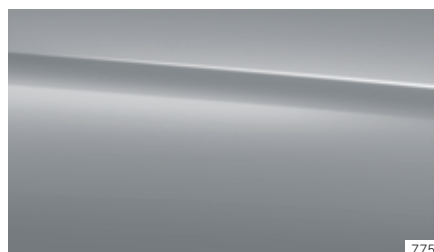
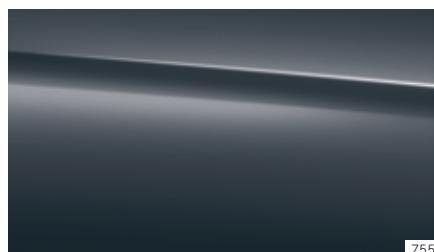
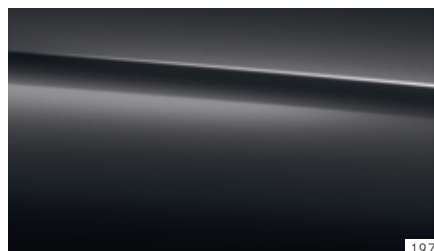

designo paints

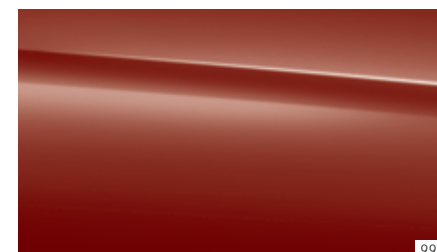

Take-back of end-of-life vehicles. At the end of its long life, you can return your SLK-Class to us for environment-friendly disposal in accordance with the European Union (EU) End-Of-Life Vehicle Directive. But that day lies a long way off.

A network of vehicle take-back depots and dismantlers has been established to make it as easy as possible for you to return your vehicle. You can leave it at any of these points free of charge and, by doing so, make an important contribution to completing the recycling process and conserving resources.

For further information about the recycling and disposal of end-of-life vehicles and take-back conditions, please visit your national Mercedes-Benz website.

Please note: changes may have been made to the product since this brochure went to press (27.01.2014). The manufacturer reserves the right during the delivery period to make changes to the design, form, colour or specification, provided these changes, while taking into account the interests of the vendor, can be deemed reasonable with respect to the purchaser. Where the vendor or the manufacturer uses symbols or numbers to describe an order or the subject of an order, no rights may be derived solely from these. The illustrations may include accessories and optional extras which do not form part of the standard specification. Actual colours may differ slightly from those shown owing to the limitations of the printing process. This brochure is distributed internationally. It provides a general indication of the range of models, features, optional extras, colours and/or services available in various countries. Some of the models, features, optional extras, colours and/or services shown may not be available in your country or may only be available in a different specification. Additionally some models, features, optional extras, colours and/or services may only be available in combination with others. For current and more specific information in relation to the range of models, features, optional extras, colours and/or services available in your country, and their pricing, you should contact your nearest authorised Mercedes-Benz Passenger Car Dealer.

www.mercedes-benz.com