



Mercedes-AMG GT.

**AMG**  
DRIVING PERFORMANCE



Mercedes-Benz



This Brochure is prepared by Daimler AG and it predominantly reflects the capabilities and performance of vehicles sold in Europe.

Some characteristics, capabilities, performance features and optional extras (e.g. towing systems) may not be available or may not apply in Australia under Australian conditions. The information in this Brochure is therefore indicative, illustrative and provided only for guidance and should not be relied on. To obtain current and accurate information on a vehicle and any options applicable to Australia, contact your local authorised Mercedes-Benz dealer.



AMG

AMG  
R 133A  
1000 x 1000  
1000 x 1000  
1000 x 1000





D S GT 190

Here it is – the statement from Affalterbach: long bonnet, cockpit positioned far back, wide and powerful rear end. These are the proportions of a sports car from Mercedes-AMG. Its instinct is to rush forward. The new Mercedes-AMG GT.

# HANDCRAFTED BY RACERS.

## High performers:

**Mercedes-AMG GT S**, AMG solarbeam, AMG cross-spoke forged wheels, Exclusive nappa leather/DINAMICA microfibre in black with yellow contrasting topstitching, AMG glass fibre trim in matt silver: page 1 ff.

**Mercedes-AMG GT S**, iridium silver, AMG 10-spoke light-alloy wheels, Exclusive nappa leather in red pepper/black, AMG matt carbon-fibre trim: page 19 ff.

18 | Light technology

22 | AMG DYNAMIC SELECT

24 | AMG DYNAMIC PLUS package

26 | Chassis and suspension

30 | 4.0-litre V8 biturbo engine

32 | Transaxle configuration

36 | Aluminium spaceframe

38 | Brake systems

42 | Equipment and appointments

52 | Wheels

54 | Standard equipment and optional extras

57 | Paintwork, upholstery and trim

# GT

There's only one car that can outstrip the new Mercedes-AMG GT:  
the new Mercedes-AMG GT S.







S





# GRIP

There's an endless variety to bends and winding roads. All designed for the ultimate hands-on driving experience. Sometimes inviting, with fresh asphalt over a gentle hilltop. Sometimes blind, rough, sloping gently down through a dip on the inside of the curve. Tilting outwards, leading through tight radii covered with foliage. Braking point. Turn-in point. Highest point. Shift point. Crying out to be tamed. At last, their call is heard.





You climb aboard and press the button. It stirs, at first with a gentle, deep breathing sound. As soon as you step on the accelerator, the two exhaust flaps of the two-mode AMG Performance exhaust system and every ounce of horsepower compose a quite unique sound. Roaring when the V8 on board the Mercedes-AMG GT unleashes its full power. Effortlessly superior when it is coasting along.

ROAR

A yellow sports car is shown from the rear three-quarter view, parked on a wet, reflective surface. The car's rear wheel, multi-spoke alloy rim, and rear fender are visible. The background features a vast, flat desert landscape with sparse, dry vegetation and distant, hazy mountains under a clear blue sky. The wet pavement creates a clear reflection of the car's rear wheel and the surrounding environment.

## Here to thrill you.

Full of intent, even when stationary. The prominent wheel arches exude power. The pronounced waistline running along the entire side wall merges into muscular shoulders. Its supreme might is concentrated in the dynamic rear end, waiting to pounce.













**WE  
DREAMT OF  
A TRUE  
DRIVING  
MACHINE.  
IT COULD  
ONLY LOOK  
LIKE THIS.**



**A BLUR**

**RESISTANCE**

**IN**

**THE**

**AIR.**





In each of the narrow LED tail lights, 18 white, centrally positioned sequentially flashing prisms of the indicator showcase the aspirations of the Mercedes-AMG GT. Fascinatingly attractive, with a characteristic night design. By integrating and visually emphasizing the turning direction in the signalling pattern of the tail lights, we have enhanced the lights' visibility and, in turn, improved the car's safety.



A close-up, low-angle shot of a car's front left headlight. The headlight is illuminated, showing a bright white light from the main projector and a glowing LED strip along the top edge. The car's body is a light color, possibly silver or white, and the background is dark, suggesting a night setting. A yellow curb is visible on the left side of the frame.

The LED High Performance headlamps exude luminous power, safety and efficiency. The LED projection technology in the low beam and the LED reflection technology in the high beam provide for optimum illumination of the road. A distinctive touch: the LED optical fibre above the low beam combines daytime running lamps and indicators.





# 3.3

## kg/hp

Its power-to-weight ratio. Vast potential to be applied to the road. In other words: traction counts. On the Mercedes-AMG GT a mechanical rear axle differential lock performs this task. The electronic differential lock on the Mercedes-AMG GT S is even more finely tuned and faster-acting. It raises the vehicle's physical limits to a new level. With its variable locking effect it is able to adapt perfectly to different driving conditions and road surface friction levels. For even greater traction, higher cornering speeds and unique driving performance.





\* Fast is not enough. The dual clutch transmission shifts gear more quickly: up to 60% faster in the sporty modes than in C mode.

The Mercedes-AMG DRIVE UNIT: your direct connection to the road. Three pre-set and one individually adjustable transmission mode can be selected via the Mercedes-AMG DYNAMIC SELECT Controller. C, S, S+ and I\* - each with its own character. The sportier the mode, the more agile the responsiveness, the shorter the shift times and the more dynamic the tuning for the Mercedes-AMG GT. Exclusive to the Mercedes-AMG GT S: RACE transmission mode. High performance to racing standard.







## AMG DYNAMIC PLUS package.

Even greater driving dynamics. This is the aim of the AMG DYNAMIC PLUS package, which is available exclusively for the Mercedes-AMG GT S. In addition to dynamic engine and transmission mounts, it offers the even firmer AMG RIDE CONTROL sports suspension, increased negative camber at the front axle, specifically tuned steering and an engine application that redefines dynamics in the RACE transmission mode and in manual mode M. Racing flair in the cockpit: the AMG Performance steering wheel in DINAMICA microfibre and the instrument cluster with yellow highlights also form part of the package.



# FULL CON

The AMG RIDE CONTROL sports suspension with adaptive damping – a standard feature on the Mercedes-AMG GT S – combines pronounced performance with the ultimate in refined ride comfort. In conjunction with the double wishbone concept it enables race track performance with excellent lateral dynamics and driving stability at high speeds. It adapts the damper characteristics of each individual wheel to the style of driving and the condition of the road.



# TACT





**THE IDEA**

**HAS ALWAYS BEEN TO BUILD AN**

**EIGHT-**

**CYLINDER**

**ENGINE LIKE NONE BEFORE IT.**



# 209\*



\*Dry weight of the AMG 4.0-litre V8 biturbo engine in kg.

Light. Compact. Powerful. The dry weight of the new AMG V8 engine stands at only 209 kg. The aluminium crankcase is sand-cast and produced in closed-deck design. This offers maximum strength combined with low weight. The two turbochargers are installed in the so-called “hot inside V”. This enables an even more compact design, an optimised airflow and perfect inflow conditions for the turbochargers. The overall result is optimum engine response and improved emissions. To ensure the highest possible thermal diffusivity and conductivity, the cylinder head alloy incorporates zircon. And for maximum durability and friction-optimised running, the cylinder walls are lined with the NANOSLIDE® technology developed by Daimler.

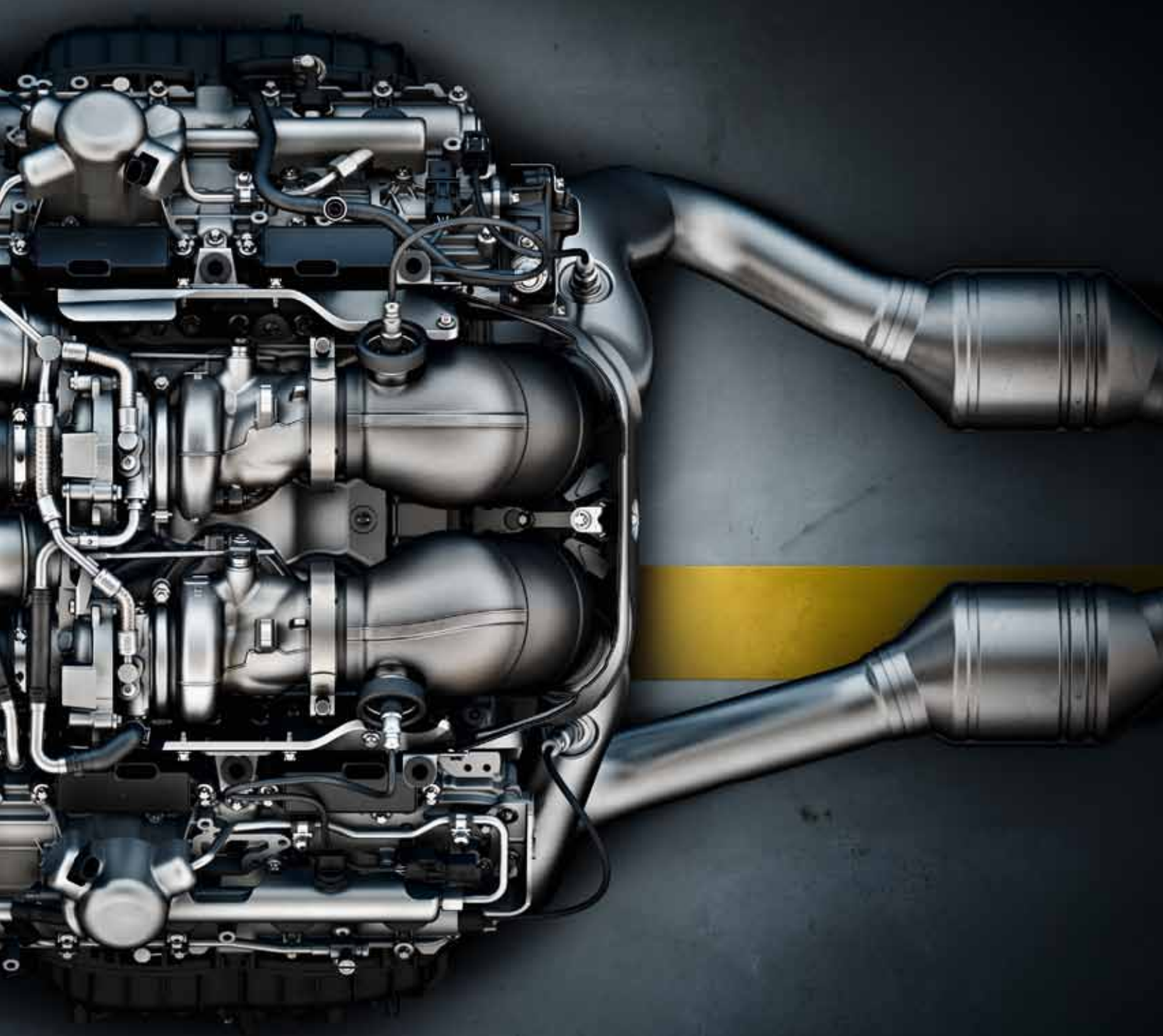

**MERCEDES-AMG GT**

The AMG 4.0-litre V8 biturbo engine delivers 340 kW (462 hp) and maximum torque of 600 Nm.

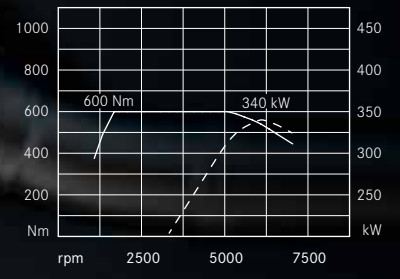

**MERCEDES-AMG GT S**

375 kW (510 hp) and maximum torque of 650 Nm. The AMG 4.0-litre V8 biturbo in the Mercedes-AMG GT S.

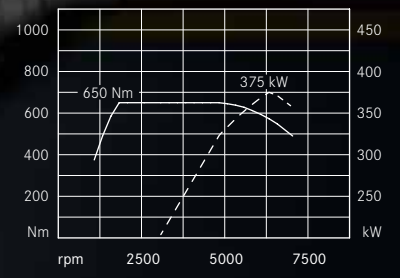

Speed in rpm  
 — Torque in Nm  
 - - Output in kW



## Primed for performance.

A sports car's excellent performance is based on optimum distribution of its weight. The aim is to attain the lowest possible centre of gravity. This is achieved with the front mid-engine which is fitted low in the aluminium spaceframe. The engine employs dry sump lubrication. Lubrication takes place via a suction pump, a pressure pump and an

external oil tank. This ensures an ideal supply of oil even at high lateral acceleration. Another aim is perfect balance. To this end, the dual clutch transmission sits on the rear axle.

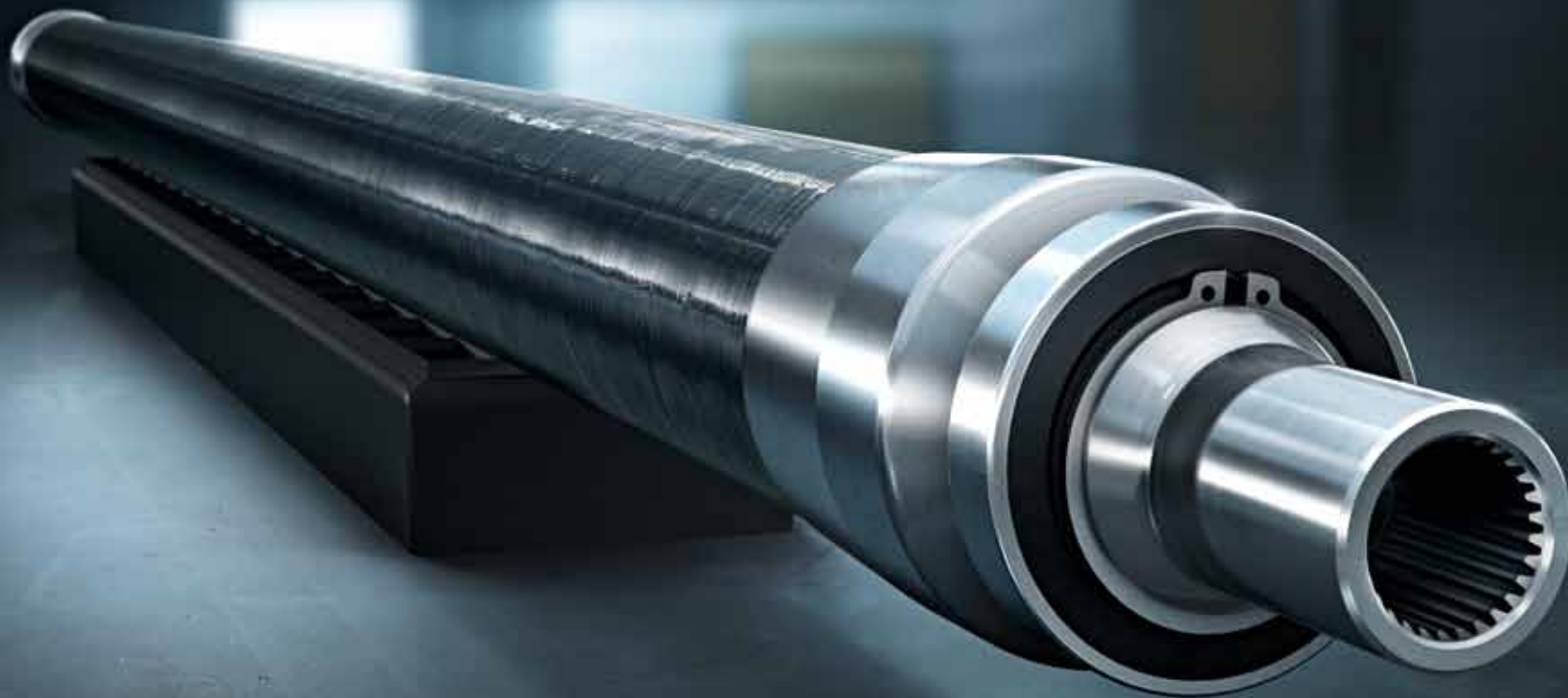

By means of a transaxle configuration we connect the front mid-engine to the dual clutch transmission positioned at the rear to form a fixed unit. The two components are connected via the a torque tube for resistance to bending and torque and support each other. An extremely light and torsion-resistant drive shaft made of carbon rotates inside, transferring

the output of the 4.0-litre V8 biturbo engine to the AMG SPEEDSHIFT DCT 7-speed sports transmission. The transmission duly converts the power into acceleration. In incredibly fast and breath-taking style.



# 47%

That is our formula for success when it comes to sports cars. Taking the balance of the new Mercedes-AMG GT as a basis, our engineers have relocated the weight a crucial step towards the rear.



# /53\*

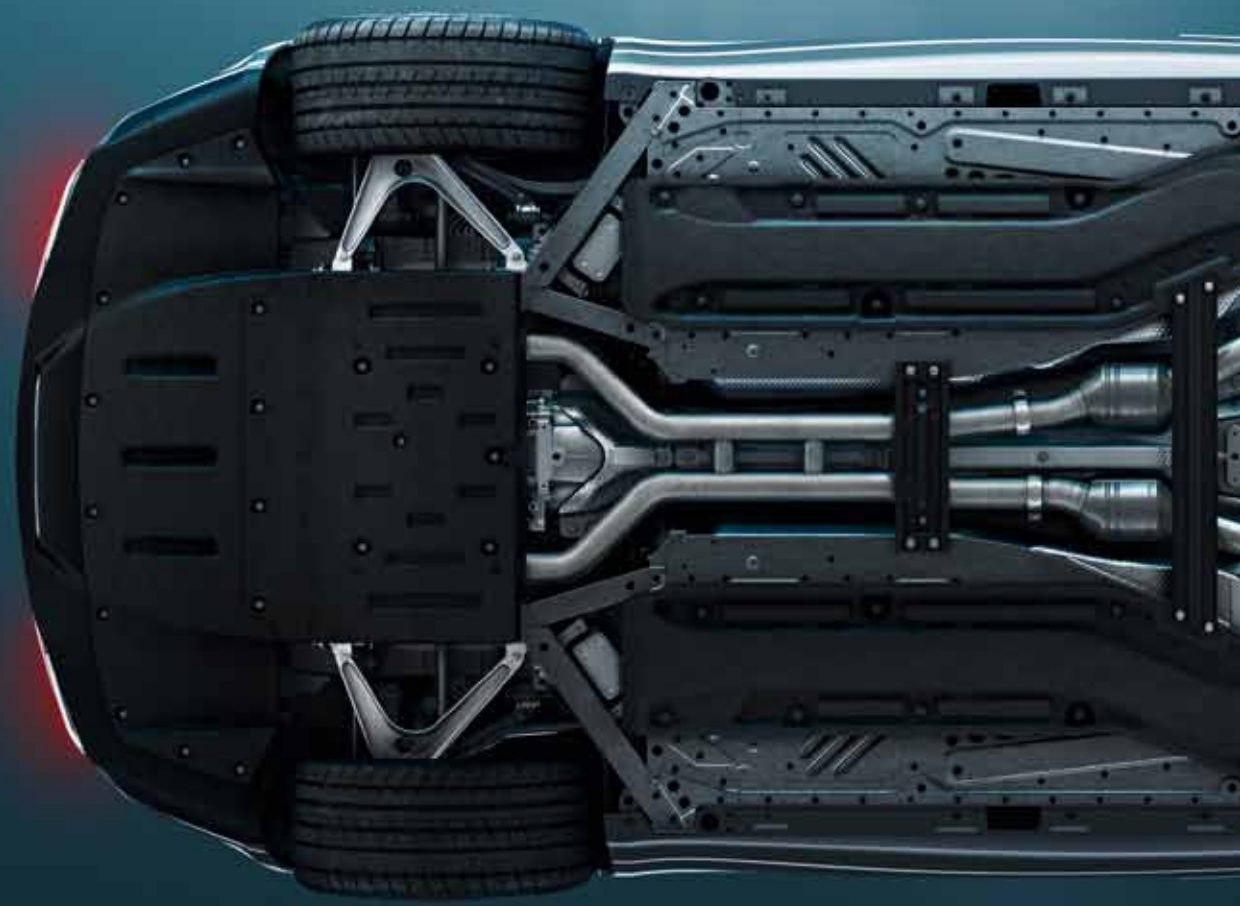

\* Lighter at the front than at the rear.

With a weight distribution of 47 to 53 percent between front and rear axle and the vehicle's lower centre of gravity, the new Mercedes-AMG GT offers unique handling and impressive agility.





## Raceframe.

Aluminium. Magnesium. Steel. These are the ingredients for the body-in-white of the new Mercedes-AMG GT. The spaceframe consists largely of aluminium and weighs only 231 kg. An innovative architecture which is light, robust and extremely rigid in one. This provides the essential basis for the best possible lateral and longitudinal dynamics and maximum steering precision. The extremely light front module made of magnesium

reduces the mass inertia ahead of the front axle and optimises the sports car's agility. The boot lid is made of high-strength steel. If we had produced it in aluminium, it would have been heavier in order to ensure the necessary rigidity. That's what we understand by intelligent lightweight design.

Brake power.



AMG high-performance composite brake system as standard for the Mercedes-AMG GT, diameter front and rear 360 mm, internally ventilated and perforated. Shortest braking distances, precise pressure point and high fade resistance.



AMG high-performance composite brake system with red brake callipers, exclusive to the Mercedes-AMG GT S. Diameter front 390 mm, rear 360 mm, internally ventilated and perforated. Designed for higher performance and enhanced braking force.



AMG ceramic high-performance composite brake system\*, diameter front 402 mm, rear 360 mm, internally ventilated and perforated. 40% lighter than conventional composite disc brakes. Maximum service life, excellent deceleration values and precision brake control even under extreme loads.



\* Optional item for Mercedes-AMG GT and Mercedes-AMG GT S.



**TRUE CRAFTSMANSHIP IS  
FOUNDED ON EXPERIENCE.  
DEDICATION. AND  
A HEALTHY  
DOSE OF  
CRAZI-  
NESS.**

A close-up, macro photograph of dark blue leather with gold stitching. The stitching is a double-stitch pattern, creating a series of parallel lines that curve across the frame. The leather has a fine, pebbled texture. The lighting is dramatic, highlighting the texture and the metallic sheen of the thread.

When we build a sports car, we go the whole mile. And no half measures in the cockpit, either. On the contrary – the design of the interior in the new Mercedes-AMG GT follows our 'Driving Performance' philosophy.

Every material we opt for and every colour and form we give it imparts the exclusive feeling of driving an AMG.





The image shows the interior of a Mercedes-AMG car. The dashboard is black with a prominent 'AMG' logo on the left. Below the logo are two circular air vents. The center console is black with a carbon fiber texture and features four circular buttons labeled '10', 'OFF', 'P', and 'TC'. The seats are red leather with black stitching. The door panel is black with a speaker and a handle. The overall aesthetic is sporty and luxurious.

## AMG. Up close.

The cockpit. This car has the AMG DNA. The dynamic centre console rises gently up to the dashboard with the four striking air vents. Radically sporty. The rev counter registers every surge into a new power dimension with consummate precision. The AMG Performance seats offer perfect lateral support in every bend. Hands on the AMG Performance steering wheel, speeding the car along via the shift paddles – this is the true feel of the road. Tailor-made for feel-good vibes with extremely high-class workmanship, finest leather and carbon fibre. Hand-crafted character.



# Tailor-made. Down to the finest decibel.

High-performance on the audio front, too. The Burmester® high-end-surround sound system has been developed especially for the architecture of the new Mercedes-AMG GT. The specialists from Burmester® and the engineers from Mercedes-AMG worked closely together to achieve a perfect sound. The special requirements pertaining to integration of the components, the materials and the sports car's acoustic attributes were examined closely. By way of example: specific sealing measures transformed the aluminium spaceframe into a perfect resonance chamber for the 165 mm high-end woofers in the footwells. The fully active Burmester® high-end surround sound system comprises 11 loudspeakers and a high-end amplifier with an output of 1000 W – for a unique audio experience and an impressive depth of sound.

*Burmester*  
HIGH END





# (S)PACEMAKER

The contenders: sportiness and space. The winner: the new Mercedes-AMG GT. Despite its sporty proportions, enough space remains for everyday needs. To be precise: 350 litres of boot capacity. The large boot lid facilitates loading the vehicle. And the strut in aluminium, or optionally in carbon fibre, matt carbon fibre or matt silver glass fibre, prevents objects from sliding around. Racing flair can be perfectly practical, too.





## AMG Exterior Carbon-Fibre package.

The stuff that racing dreams are made of: carbon fibre. The front splitter, the fins in the wing, the exterior mirror housings and the one-piece diffuser in the rear bumper are all made of carbon fibre. The louvre in the diamond grille comes in high-gloss black. Pure dynamism that emphasizes the forward thrust of the new Mercedes-AMG GT.





## AMG Exterior Silver Chrome package.

The cool, deep transparent look of the silver chrome coating highlights selected elements, such as the front splitter, the fins in the wings and the trim strip in the diffuser to best advantage. The diamond grille with pins in chrome and the aluminium roofline trim strip in silver above the side windows round off the exclusive appearance.





## AMG Exterior Night package.

A statement. Expressive and sporty with features in high-gloss black. From the front splitter through the louvre in the black diamond grill, the fins in the wings and the exterior mirror housings to the trim strip in the diffuser on the rear apron. Two black tailpipes add a powerful finishing touch. The triangular side windows and the rear window feature heat-insulating dark-tinted glass.

## Pit stop.

Whichever set you go for, the AMG light-alloy wheels and the AMG forged wheels offer grip, agility and driving dynamics. Lightweights that make their mark on the road.

**662** | 10-spoke AMG light-alloy wheels, painted in vanadium silver, with 255/35 R 19 front and 295/35 R 19 rear tyres.

**793** | 5-twin-spoke AMG light-alloy wheels, painted in vanadium silver, with 255/35 R 19 front and 295/35 R 19 rear tyres.

**699** | 10-spoke AMG light-alloy wheels, painted in titanium grey, with 265/35 R 19 front and 295/30 R 20 rear tyres.

**657** | 10-spoke AMG light-alloy wheels, painted in titanium grey with a high-sheen finish, with 265/35 R 19 front and 295/30 R 20 rear tyres.





765



658



663



659

**765** | 5-spoke AMG light-alloy wheels, painted in titanium grey with a high-shine finish, with 265/35 R 19 front and 295/30 R 20 rear tyres.

**663** | 5-spoke AMG light-alloy wheels, painted in matt black grey and with a high-shine rim flange, with 265/35 R 19 front and 295/30 R 20 rear tyres.

**658** | AMG cross-spoke forged wheels, painted in titanium grey and polished, including fully integrated wheel bolt cover, with 265/35 R 19 front and 295/30 R 20 rear tyres.

**659** | AMG cross-spoke forged wheels, painted in matt black with high-shine rim flange, including fully integrated wheel bolt cover, with 265/35 R 19 front and 295/30 R 20 rear tyres.



1



2



3



4



5



6

# Standard equipment.

## Selection.

- 1 AMG sports seats with ARTICO man-made leather/fabric upholstery in black.
- 2 LED High Performance headlamps. Innovative LED technology for optimum illumination and reduced energy consumption.
- 3 Dashboard in ARTICO man-made leather with sporty contrasting topstitching.
- 4 The right climate at all times. With two climate zones and three climate styles, THERMOTRONIC automatic climate control ensures an individual atmosphere in the cockpit. The temperature can be controlled separately for driver and front passenger.
- 5 Instant joy at the push of a button. Just press the button for the KEYLESS-GO starting function to experience high performance.
- 6 COLLISION PREVENTION ASSIST PLUS gives the driver a visual warning if the distance to the vehicle in front is too short. An audible warning sounds when a danger of collision is identified. The system is also able to support the driver's braking action, or to reduce the speed by means of autonomous braking intervention, should the driver fail to respond to the warning.

# Optional equipment.

## Selection.

1 The sky's the limit. The large panoramic roof spans the entire roof area to conjure up a light and airy atmosphere. The all-glass look lends the vehicle an even lighter appearance.

2 Blind Spot Assist forms part of the Lane Tracking package. When a vehicle is detected in the blind spot, a red triangle lights up in the exterior mirror. If the driver overlooks this warning and operates the direction indicators, an audible warning is additionally sounded.

3 Fast on the road, fast on the net. With the COMAND Online multimedia system the driver has everything in sight – from navigation to internet. Information is shown on a 21.3 cm high-resolution colour display.

4 Top-class on the audio front, too. The Burmester® surround sound system – only available in conjunction with COMAND Online – offers unrivalled sound quality with ten high-performance speakers, a 10-channel DSP amplifier with a total output of 640 W and precisely coordinated electronic and acoustic elements.

5 On track. The AMG door sill panels in carbon fibre conjure up a race-track atmosphere as soon as the doors are opened.

6 Bring on the bends. The AMG sports seats with upholstery in silver pearl/black nappa leather not only look very sporty, they offer ideal lateral support, too.





## Enough said.

	MERCEDES-AMG GT	MERCEDES-AMG GT S		MERCEDES-AMG GT	MERCEDES-AMG GT S
Arrangement/number of cylinders	V8	V8	Fuel consumption <sup>3</sup> in l/100 km, urban/extra-urban/combined	12.2/7.6/9.3	12.5-12.2/7.9-7.8/9.6-9.4
Total displacement in cc	3982	3982	CO <sub>2</sub> emissions <sup>2</sup> in g/km, combined	216	224-219
Rated output <sup>1</sup> in kW (hp) at rpm	340 (462)/6000	375 (510)/6250	Emission class <sup>4</sup> /efficiency class <sup>5</sup>	Euro 6/G	Euro 6/G
Rated torque <sup>1</sup> in Nm at rpm	600/1600-5000	650/1750-4750	Tank capacity in l/incl. approx. reserve	65/10.0	65/10.0
Acceleration from 0 to 100 km/h (s)	4.0	3.8	Luggage compartment capacity in l <sup>6</sup>	285-350	285-350
Top speed in km/h	304 <sup>2</sup>	310 <sup>2</sup>	Turning circle diameter in m	11.50	11.50
Tyre size – front, rear	255/35 ZR 19, 295/35 ZR 19	265/35 ZR 19, 295/30 ZR 20	Kerb weight in kg	1540 <sup>7</sup> /1615 <sup>8</sup>	1570 <sup>7</sup> /1645 <sup>8</sup>
Fuel	Super Plus petrol	Super Plus petrol			

<sup>1</sup> Figures for rated output and rated torque in accordance with Directive 80/1269/EEC in the currently applicable version. <sup>2</sup> Electronically governed. <sup>3</sup> The figures shown were obtained in accordance with the prescribed measuring process (Directive [EC] 715/2007 in the currently applicable version). Note according to Directive 1999/94/EC in the currently applicable version: The information does not refer to a specific vehicle and is not part of the offer, but is exclusively for purposes of comparison between the various vehicle models. <sup>4</sup> Valid only within the European Union.

<sup>5</sup> Determined on the basis of the measured CO<sub>2</sub> emissions with due consideration of the mass of the vehicle. <sup>6</sup> Information according to Directive 70/156/EEC in the version 2000/40/EC. <sup>7</sup> Information according to Directive 92/21/EC in the version 95/48/EC (mass in running order, fuel tank 90% full, without driver and luggage) for standard-specification vehicles. Optional extras and accessories will generally increase this figure and reduce the payload capacity accordingly. <sup>8</sup> Figures according to Directive 92/21/EC, version 95/48/EC (kerb weight with fuel tank 90% full, driver, 68 kg, and luggage, 7 kg) for standard-specification vehicles. Optional extras and accessories will generally increase this figure and reduce the payload capacity accordingly. [www.mercedes-benz.com](http://www.mercedes-benz.com)



# Time to drive it.

Climb aboard and experience the new Mercedes-AMG GT on a test drive. Your Mercedes-Benz dealer will be happy to advise you.

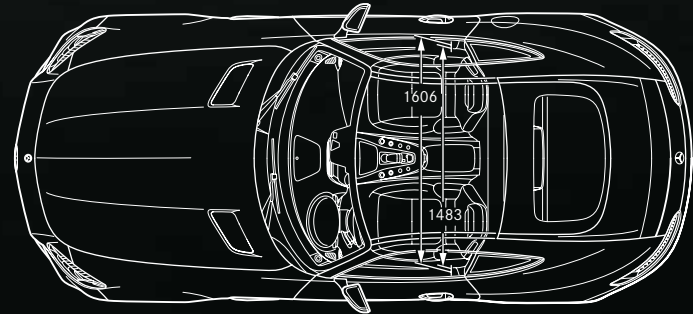
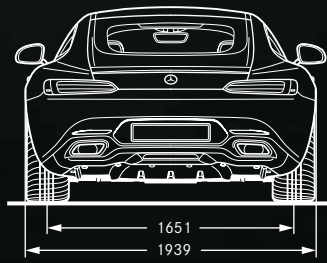
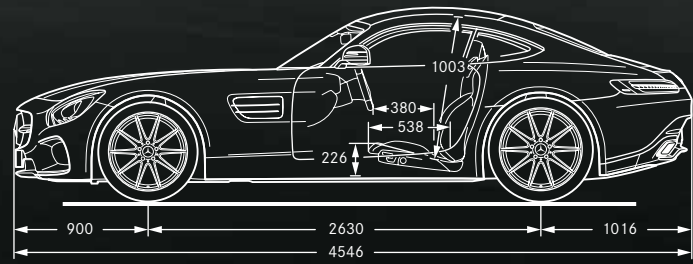
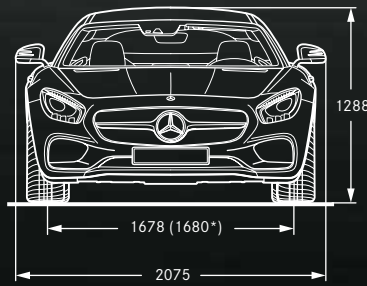

\* Figures apply to the Mercedes-AMG GT S.

All dimensions in millimetres. The dimensions shown are mean values and apply to standard-specification, unladen vehicles.

NON-METALLIC PAINTS —

040 black

590 fire opal

183 magnetite black

775 iridium silver

896 brilliant blue

992 selenite grey

278 AMG solarbeam

799 designo diamond white bright

996 designo hyacinth red metallic

297 designo selenite grey magno

982 designo iridium silver magno

METALLIC PAINTS

SPECIAL PAINTS



731 ARTICO/fabric in black  
(standard for Mercedes-AMG GT)

641 ARTICO/DINAMICA in black  
(standard for Mercedes-AMG GT S)

801 Nappa leather in black  
501 Exclusive nappa leather in black

804 Nappa leather in marron  
504 Exclusive nappa leather in marron

555 Exclusive nappa leather in white/black

857 Nappa leather in red pepper/black  
557 Exclusive nappa leather in red pepper/black

858 Nappa leather in silver pearl/black  
558 Exclusive nappa leather in silver pearl/black

601 Exclusive nappa leather/DINAMICA  
in black with yellow contrasting topstitching

621 Exclusive nappa leather/DINAMICA  
in black with grey contrasting topstitching

631 Exclusive nappa leather/DINAMICA  
in black with red contrasting topstitching

564 Exclusive nappa STYLE  
leather in saddle brown with diamond pattern

H70 AMG Interior Silver Chrome package  
(standard)

H80 AMG Interior Black Diamond package

H73 AMG carbon fibre

H77 AMG carbon fibre, matt

H84 AMG glass fibre, matt silver

**Take-back of end-of-life vehicles.** We will be glad to take back your Mercedes-AMG GT for proper recycling and disposal as specified by the end-of-life vehicle directive of the European Union (EU) – even though that day is a long way away.

A network of vehicle take-back depots and dismantlers has been established to make it as easy as possible for you to return your vehicle. You can leave it at any of these points free of charge and, by so doing, make an important contribution to completing the recycling process and conserving resources.

For further information about the recycling and disposal of end-of-life vehicles and take-back conditions, please visit your national Mercedes-Benz website.

**Please note:** changes may have been made to the product since going to press (12.12.2014). The manufacturer reserves the right during the delivery period to make changes to the design, form, colour or specification, provided these changes, while taking into account the interests of the vendor, can be deemed reasonable with respect to the purchaser. Where the vendor or the manufacturer uses symbols or numbers to describe an order or the subject of an order, no rights may be derived solely from these. The illustrations may include accessories and optional extras which do not form part of the standard specification. Actual colours may differ slightly from those shown, owing to the limitations of the printing process. This brochure is distributed internationally. Information given regarding statutory regulations, legal requirements and taxation and the consequences thereof applies to the Federal Republic of Germany only and is correct at the time of going to press. For current and more specific information in relation to the range of models, features, optional extras, colours and/or services available in your country, and their pricing, you should contact your nearest authorised Mercedes-Benz Passenger Car Dealer.

[www.mercedes-benz.com](http://www.mercedes-benz.com)