

# The CLA Coupé and Shooting Brake



Mercedes-Benz



This Brochure is prepared by Daimler AG and it predominantly reflects the capabilities and performance of vehicles sold in Europe. Some characteristics, capabilities performance features and optional extras (e.g. towing systems) may not be available or may not apply in Australia or under Australian conditions. The information in this brochure is therefore indicative, illustrative and provided only for guidance and should not be relied on. To obtain current and accurate information on a vehicle and any options applicable to Australia, contact your local authorised Mercedes-Benz dealer.



# Rock. Star.

Spotlight on. The excitement is building. It's nearly time for the CLA Coupé and CLA Shooting Brake to make their big entrance. The latest trendy neighbourhoods are turned into a stage – quiet side streets become the backstage area. Get ready for an exclusive “meet & greet” with the most thrilling vehicles in their class.

**ROCKS IN EVERY FORMAT.**



Explore the CLA Coupé and the CLA Shooting Brake on your iPad®. The Mercedes-Benz brochure app, with a host of additional content, is available free of charge from the iTunes Store®.

## The band:

### 4 | Mercedes-Benz CLA 250 Coupé polar silver

AMG Line, multi-spoke light-alloy wheels, AMG Exclusive package, black RED CUT leather upholstery, light longitudinal-grain aluminium trim

### 14 | Mercedes-Benz CLA 200 d 4MATIC Shooting Brake cavansite blue

Urban equipment line, 5-twin-spoke light-alloy wheels, Exclusive package, nut brown leather upholstery, dark honeycomb-grain aluminium trim

### 64 | Mercedes-AMG CLA 45 4MATIC Shooting Brake cavansite blue

AMG Night package, AMG cross-spoke light-alloy wheels, ARTICO man-made leather/DINAMICA microfibre upholstery, AMG Performance seats, black AMG DINAMICA microfibre trim

### 70 | Mercedes-AMG CLA 45 4MATIC Coupé polar white

AMG Night package, AMG cross-spoke light-alloy wheels, ARTICO man-made leather/DINAMICA microfibre upholstery, AMG Performance seats, black AMG DINAMICA microfibre trim

## The instruments:

26 | Mercedes-Benz Intelligent Drive

28 | Mercedes me

32 | Services

36 | Engines

38 | 7G-DCT dual-clutch transmission

39 | 4MATIC all-wheel drive

40 | Mercedes me connect

41 | Multimedia systems

42 | Panoramic sliding sunroof

43 | Ambient lighting

46 | Standard equipment

48 | Optional extras

50 | Equipment and packages

57 | Genuine Accessories

58 | CLA 250 Sport and CLA 250 Sport 4MATIC

60 | Wheels

62 | Mercedes-AMG models

82 | Technical data, dimensions, upholstery, trim and paintwork





The rock star generation: few have more followers. Hardly surprising, because the sporty styling has been even further honed. There are now even more opportunities for networking. The performance on the road is virtuoso – courtesy of engines that as powerful as they are efficient, DYNAMIC SELECT (availability dependent on model) and an optionally available suspension with adaptive damping adjustment.

# Bad boy

in good shape.

A selfie with the CLA Coupé is in particularly high demand. The bumper with its front apron and lower trim element in silver, black or chrome, plus the diamond radiator grille, just have to be in the picture too. 45.7 cm (18-inch) light-alloy wheels in a wide range of designs get even more Likes.









The CLA Coupé wouldn't dream of fleeing from the paparazzi. Indeed, why should it? Its avant-garde design ensures that it sets standards. No one can miss that taut coupé silhouette and the muscular rear end with its integrated tailpipe trims and optional LED tail lights. But the CLA makes sure that others share the limelight: with its optionally available LED High Performance headlamps.



# Love & pace.

What a spectacular show! Use DYNAMIC SELECT (availability dependent on model) to set the drive program to “Sport” and make sure your seat belt is securely fastened. Ahead of you lies not just a journey from A to B. Follow your own rhythm alone through the curves. The stiffer tuning of the suspension with adaptive damping adjustment, available as an option, allows a significantly more agile style of driving.







The image shows the front interior of a car. The seats are upholstered in dark leather with a perforated pattern on the backrests and seat cushions. Red stitching is visible along the edges of the leather. The center console is partially visible in the foreground, featuring a gear shifter and handbrake. The background shows a window with a blue, perforated mesh screen.

The coupé with the special glamour factor: enjoy an interior that has been refined with elegant chrome trim, along with the seat covers of the optional Urban line and the optional Exclusive package. The 20.3 cm (8-inch) media display available for the multimedia systems rounds off this perfectly composed appearance with a narrow chrome-look frame.







More  
heartbeats  
per minute.

# Access

all areas.

The CLA Shooting Brake is always the focus of attention, even off the big stage. Courtesy of its standard-specification diamond radiator grille, its bumper with trim strip and its distinctively styled front apron, all in conjunction with the vehicle colour cavansite blue. You're really keen to take a look behind the scenes? HANDS-FREE ACCESS is an optional extra that enables fully automatic opening and closing of the tailgate on the CLA Shooting Brake. In conjunction with the optional KEYLESS-GO Convenience package, all it takes is a kicking motion underneath the rear bumper.









Don't drive.

Perform.



The performance of the CLA is sure to earn standing ovations all the way along the racing line. Even Mother Nature joins in with the applause, thanks to the eco-friendlier BlueEFFICIENCY Edition model.





Get as close as possible to the CLA. With the optionally available Smartphone Integration package, including Apple CarPlay™ and Android Auto, you can link directly to your vehicle. Explore selected apps from your smartphone, your music library and so much more, in the CLA. Welcome to the VIP area.





# Security

service.

Innovative assistance systems ensure your safety at all times. The optionally available Distance Pilot DISTRONIC, for example, automatically maintains a safe distance from the vehicle ahead. ATTENTION ASSIST is able to detect typical signs of fatigue and to warn the driver of an impending microsleep. The reassuring side of the CLA also becomes evident when manoeuvring into or out of a parking space: the dynamic guide lines of the optional reversing camera provide valuable help.







Sexiest cars  
alive.



## Mercedes-Benz Intelligent Drive – pointing the way to accident-free and autonomous driving.

Mercedes-Benz is the first automotive manufacturer worldwide to have developed an integral safety concept, with the aim of safe driving, responding in an appropriate manner to hazards, avoiding accidents and mitigating the consequences of accidents. For the occupants of a Mercedes and for all other road users, too.

Mercedes-Benz Intelligent Drive forms part of this integral safety concept. It makes your Mercedes one of the most intelligent automobiles in the world – an “intelligent partner”. The Mercedes-Benz Intelligent Drive assistance systems are able to recognise hazards, provide timely warnings and even intervene autonomously when necessary – by performing braking manoeuvres, for example. In this way, accidents can be prevented or the severity of accidents can be significantly reduced. In order to protect passengers as necessary in case of danger, additional protective features such as PRE-SAFE® are activated as anticipatory measures. These features vary according to the model concerned.

Many Mercedes-Benz vehicles already offer the option of a Driving Assistance package. The key functions of this package include partially automated driving on motorways, on country roads and in built-up areas. The Driving Assistance package also lends support when changing lane on multi-lane roads, for example during overtaking. This relieves the driver’s workload, as in normal driving they no longer need to brake or accelerate. The driver also receives substantial support with steering – even in bends.

Never before have safety, comfort and measures to reduce the strain on the driver been combined so effectively. This intelligent and pioneering interplay of sensors and safety and assistance systems represents a milestone on the road to autonomous and accident-free driving. And a fascinating new experience into the bargain.



↘ FIND OUT MORE

For the full information on Mercedes-Benz Intelligent Drive,  
please go to [www.mercedes-benz-intelligent-drive.com](http://www.mercedes-benz-intelligent-drive.com)

Mercedes  me

Our world in your hands.

[www.mercedes.me](http://www.mercedes.me) – it's all about you. Discover a world of fascinating services, products and innovations that will simplify and enrich your life. Coming straight to you in digital form. And turning our world into your world.







## Life can be so fascinating when you're fully connected.

All our connectivity and mobility services plus a host of other fascinating features – all in one place and exclusively for you. That's Mercedes me. Register free of charge today and make the world of Mercedes-Benz your very own at your convenience – on your PC or laptop or in mobile mode via tablet, smartphone or smartwatch. And because your life is forever changing, our services are also continually evolving. Join us now at: [www.mercedes.me/welcome](http://www.mercedes.me/welcome)

Looking for individual inspiration in real life, too? The Mercedes me Stores are a fascinating phenomenon worldwide – in Beijing, Moscow and Hamburg, for example.



**Mercedes me connect** connects you with your vehicle – and your vehicle with the whole world. A comprehensive range of convenient connectivity services relating to all areas of your vehicle supports you, ensuring greater safety, closer contact and an even more fascinating driving experience. It's reassuring to stay connected all the time while you're on the move. Mercedes me connect includes Standard Services, which are able to provide you with automatic support in the event of a breakdown or an accident, as well as Remote Online Services – the option enabling vehicle settings to be carried out by smartphone – and lots more besides.

**Mercedes me inspire** offers special brand experiences and an opportunity to engage in an inspiring dialogue. We aim to share our ideas with you and we would like to know your ideas and wishes. So that we can always offer you the best solutions. A community is available to this end, and you will also find a growing range of offerings and experiences which go beyond the traditional vehicle-related topics – from areas such as events, travel and lifestyle.

**Mercedes me move** offers access to intelligent mobility solutions: car2go is the pioneer and global market leader in free-floating car sharing, the moovel mobility app pools the offerings from various mobility providers to find the ideal route from A to B. With the mytaxi app you can order a taxi, track its approach live and pay for your journey in a convenient manner. Mercedes-Benz Rent offers vehicles to suit all occasions for short- or long-term rental from an authorised Mercedes-Benz dealer near you. Blacklane enables you to book a chauffeur-driven limousine, FlixBus offers inexpensive, comfortable and environment-friendly trips on long-distance coaches.

**Mercedes me assist** makes easy work of organising maintenance for your vehicle, providing a convenient online means of locating a Mercedes-Benz dealer in your neighbourhood and arranging a service appointment. The digital service report keeps you up to date on performed service work. The report can be made available to you online just one day after a service. In addition to the current service report, you can also view your vehicle's complete service history and service intervals, and you can print this information out if you so wish.

**Mercedes me finance** offers you various routes to your vehicle of choice. Mercedes-Benz Bank/Mercedes-Benz Financial Services finds the ideal leasing, financing and insurance solution together with you – tailored to your needs. Our leasing products enable you to drive the latest models at all times while enjoying maximum flexibility, as you pay not for acquisition of the vehicle, but only for its use. You also benefit from attractive monthly instalments. Our financing arrangements enable you to pay for your new Mercedes-Benz in a way that suits your personal budget. You can tailor your monthly instalments to your needs by deciding on an appropriate down-payment and term for your contract. Our individual insurance solutions offer reliable protection for your budget and your vehicle on attractive terms. Your existing financial contracts can be managed conveniently online.<sup>1</sup>

<sup>1</sup> Depending on market availability.

## Our service: the perfect fit for your Mercedes.

Beyond the car itself, you also acquire something priceless – an exclusive partnership with Mercedes-Benz. For you, this means safety, independence and motoring free of any worries. In other words: the reassuring feeling of driving a Mercedes.

**The best for your Mercedes.** No-one knows your Mercedes better than our experienced specialists at the Mercedes-Benz workshops. The comprehensive range of services and the high standard of quality ensure that your vehicle is in top condition. We use proven Mercedes-Benz GenuineParts and special tools to this end.

**The best for you.** Motoring free of any worries right from the word go: with the tailor-made Mercedes-Benz Service Contracts. These offer you the benefits of a reliable basis for long-term planning, permanent control over costs, fixed monthly rates and cost transparency. Plus ideal protection from additional workshop costs.

**The best for your mobility.** The Mercedes-Benz Mobilo<sup>1</sup> mobility solution provides for motoring free of any worries throughout Europe – covering breakdowns, accidents, minor mishaps and vandalism. The benefits offered by Mobilo include on-the-spot assistance, a replacement vehicle, towing and overnight hotel accommodation, for example. Mobilo comes free of charge for the first two years after initial registration and can subsequently be renewed each time the vehicle is serviced by an authorised service partner, for a period of up to 30 years in all. Whenever you need assistance, you can reach us free of charge throughout Europe on 00800 1 777 7777<sup>2</sup>.

### ↘ FIND OUT MORE

For the full information on Mercedes-Benz Service Contracts, go to [www.mercedes-benz.com](http://www.mercedes-benz.com) – or ask your authorised Mercedes-Benz dealer to draw up an individual offer for you.

<sup>1</sup> Our general terms and conditions apply. The period of validity is extended after each service carried out by an authorised Mercedes-Benz service partner until the due date for the next service – up to a maximum of 30 years after initial registration. <sup>2</sup> Roaming charges may apply when calling from abroad.



## What would motorsport be without Mercedes-Benz?

The first vehicle to ever win an automobile race was powered by a Daimler engine. The first Mercedes was a racing car. The Silver Arrows – a true legend. Mercedes-Benz has a long tradition of involvement with the world of sport. Motorsport shapes the brand and every vehicle bearing the Mercedes star to this day. Discover the brand's unique history first-hand: at the Mercedes-Benz Museum in Stuttgart.

### ↘ FIND OUT MORE

Discover just what has been moving the world for over 130 years and take a journey through time as well as through the history of the automobile at the Mercedes-Benz Museum. More than 1500 exhibits await you on 16,500 m<sup>2</sup> of floorspace, including unique gems such as the oldest surviving Mercedes from 1902 or the legendary gull-wing models. Welcome to a place of innovation:

[www.mercedes-benz.com/museum](http://www.mercedes-benz.com/museum)

[www.facebook.com/mercedesbenzmuseum](https://www.facebook.com/mercedesbenzmuseum)

[www.instagram.com/mercedesbenzmuseum](https://www.instagram.com/mercedesbenzmuseum)

[www.twitter.com/mb\\_museum](https://www.twitter.com/mb_museum)

[www.google.com/+mercedesbenzmuseum](https://www.google.com/+mercedesbenzmuseum)

[www.youtube.com/mercedesbenzmuseum](https://www.youtube.com/mercedesbenzmuseum)



## What would Mercedes-Benz be without motorsport?

3 June 1934 marked the beginning of the Silver Arrows legend in the International Eifel Race at the Nürburgring. Today this legend is more alive than ever: in 2016 the Silver Arrows works team Mercedes-AMG Petronas Motorsport won the Formula 1 constructors' and drivers' titles for the third year in a row, making history by winning 19 of the 21 Grand Prix races. In a spectacular finale in the desert city of Abu Dhabi, Nico Rosberg secured his first world championship title in his Mercedes-Benz F1 W07 Hybrid. The value of these successes extends way beyond the race track: every mile raced advances development in fields such as lightweight materials and hybrid technology for series production.

### ↘ FIND OUT MORE

Fascinating Formula 1 goes multimedia:  
[www.facebook.com/MercedesAMGF1](https://www.facebook.com/MercedesAMGF1)  
[www.twitter.com/MercedesAMGF1](https://www.twitter.com/MercedesAMGF1)  
[www.youtube.com/MercedesAMGF1](https://www.youtube.com/MercedesAMGF1)  
[www.google.com/+MercedesAMGF1](https://www.google.com/+MercedesAMGF1)  
[www.instagram.com/MercedesAMGF1](https://www.instagram.com/MercedesAMGF1)  
[www.MercedesAMGF1.com](http://www.MercedesAMGF1.com)  
[www.mercedes-benz.com/motorsport](http://www.mercedes-benz.com/motorsport)









### CLA 200 d

Maximum torque on its own is not enough for happiness. Only when it sets in as early as in the CLA does it lead to a superbly assured ride, courtesy of the low revs.

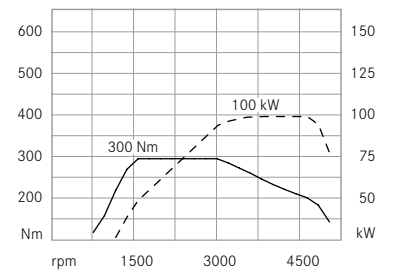

Engine speed (rpm)

Torque (Nm)

Output (kW)

















































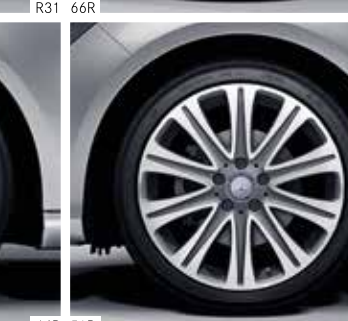
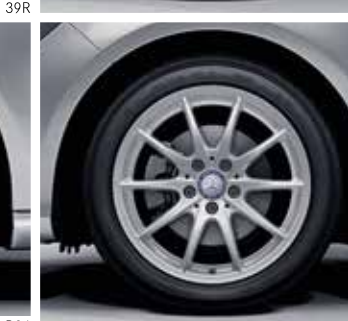





05R



612



646



796



637



780



638



678



791



760



756



693



787



99R

# Progress. Accelerated. The Mercedes-AMG CLA 45 4MATIC Shooting Brake and Coupé.

Mercedes-AMG is more than just a manufacturer of performance vehicles – AMG is a promise: the promise always to go a step further. To expect a lot and to give everything. That's how we create exceptional motor cars for exceptional people.

Built to impress. The city. The people. The asphalt.  
The Mercedes-AMG CLA 45 Shooting Brake and the  
Mercedes-AMG CLA 45 Coupé.

Welcome to the world of AMG.

 **AMG**  
DRIVING PERFORMANCE







# The shape. Perfect.

The facelift underscores the dynamic look of the Mercedes-AMG CLA 45 Shooting Brake significantly further. The distinctive front end is dominated by the AMG radiator grille with twin louvres in silver chrome and the characteristic AMG front apron in A-wing design. The front splitter insert in matt titanium grey, together with high-gloss black flics, improve the flow of cooling air. The 19-inch cross-spoke light-alloy wheels impress from the side. The aerodynamically optimised tail end rounds off the expressive overall impression. As even the very first glance makes clear: in a compact racer from AMG you will always be leading the pack.

# SHOOTING BRAKE





## Something very special. Further refined.

Anyone settling into the AMG performance seats with their stronger contouring and integrated head restraints is met with high-quality materials and sporty elegance. The seat cushion and backrest offer even better lateral support and help to define the unique sporty look of the interior. The standard AMG E-SELECT lever and the optionally available AMG Performance steering wheel with silver-coloured aluminium shift paddles further round-off the dynamic-looking interior. All that's left to do: fasten your seat belt and full power ahead.



# The drive system. Perfected.

When it comes to setting standards, too, you'll always find AMG in the fast lane. The best example for this is the 2.0-litre unit in the Mercedes-AMG CLA 45. With an output of 280 kW (381 hp), this engine's efficiency is as compelling as its performance. The NEDC consumption is just 6.9 l/100 km. A technical masterpiece, then, produced by hand according to the "One Man - One Engine" principle. In other words: true passion for racing, that you can feel all the time. Or hear - in the unmistakable sound signature of the AMG sports exhaust system.









COUPÉ

# The driving dynamics. Intensified.

What is the next step for driving dynamics? The AMG DYNAMIC PLUS package in the Mercedes-AMG CLA 45 Coupé. It includes the manually controlled AMG front axle locking differential. For optimum traction in all driving situations. Also part of the package are the AMG performance steering wheel, the AMG RIDE CONTROL sports suspension with adaptive damping adjustment plus the RACE drive program. The name delivers on the promise: RACE is configured for the ultimate in dynamic handling and is the ideal choice for chasing after record times. On the race track. Not on the way to the baker's.



## The urge. Driven on.

The rear end of the Mercedes-AMG CLA 45 Coupé has been discernibly refined, in a reflection of the motto “More power, less lift”. The AMG spoiler lip is responsible for a crucial improvement in the car’s aerodynamic performance. The AMG diffuser-look rear apron with four vertical fins furthermore optimises the air flow. The overall progressive character of the vehicle is also emphasised by the chrome-plated twin tailpipe finishers of the AMG sports exhaust system and the “TURBO 4MATIC” lettering on its flanks. Pure dynamism, in fact. Which pretty much sums up the Mercedes-AMG CLA 45 Coupé.





# The handling. Refined.

Perfect handling calls for optimum operability. The AMG DRIVE UNIT takes care of that. It is the central command centre for the AMG SPEEDSHIFT DCT 7-speed sports transmission and the DYNAMIC SELECT drive programs, which you can change just by turning the rotary switch. The AMG high-performance braking system delivers excellent deceleration and precise metering. The AMG Aerodynamics package, comprising a larger front splitter plus additional flics on the front apron, increases the downforce. So that you can allow the AMG light-alloy wheels unbridled freedom.



# The fun of driving. Enhanced.

The development of the 3-stage Electronic Stability Program (ESP®) saw the contradiction between safety and driving enjoyment eliminated. The ESP® button allows the driver to choose between three control strategies: “ESP® ON” for a high level of safety, “ESP® SPORT HANDLING MODE” for a sportier driving style and “ESP® OFF” for driving on dedicated racetracks. In addition, the AMG RIDE CONTROL sports suspension helps to deliver the engine output better to the asphalt. Whatever happens: you can depend on your vehicle’s performance.







# The technology. Revolutionised.

What do AMG drivers and AMG engineers have in common? They are petrol heads. As proved by the world's most powerful series-production 4-cylinder turbocharged engine, delivering 280 kW (381 hp). With an output per litre of 141 kW/l (191 hp/l) it out-performs even most super sports cars. A twin-scroll turbo-charger ensures fast response and maximum agility. With up to 475 Nm of torque at your disposal to achieve this.

Meanwhile, the AMG Performance 4MATIC all-wheel drive system ensures that the potential is optimally distributed to all four wheels. The optional AMG DYNAMIC PLUS package with a manually controlled front axle limited-slip differential even manages to increase the traction. With the result that, ultimately, you may reach the limits of what is physically possible, but not of your driving enjoyment.









Passion grows when it is shared: the AMG Private Lounge is our community centred on the world of AMG. AMG customers can come here for a chance to attend top-class events and use our online platform to chat about the latest developments from Affalterbach. Doing so allows them to benefit from special offers and from the direct link to AMG's headquarters: [www.mercedes-amg.com/privatelounge/welcome](http://www.mercedes-amg.com/privatelounge/welcome)



The AMG Driving Academy stands for an incomparable team spirit: experience performance with like-minded individuals and improve your driving skills at racetrack and lifestyle events held at the most breathtaking locations around the world. Become part of the "World's Fastest Family": [www.mercedes-amg.com/driving-academy](http://www.mercedes-amg.com/driving-academy)

Still want more? Mercedes-AMG Motorsport offers the ideal platform for professional motorsport in the form of its Customer Racing Program – and with the Mercedes-AMG GT3, a racing car that has been specifically designed for the very purpose. A fully integrated service environment allows you to participate in motorsport at the highest level: [www.mercedes-amg.com/customerracing](http://www.mercedes-amg.com/customerracing)

The AMG Performance Studio creates cars that are perfectly tailored to your wishes and desires. No limits are placed on the creativity of our experts, who demonstrate their unparalleled craftsmanship in areas as varied as special technical components, extravagant paint finishes and the most exclusive interior appointments imaginable, to produce one-off masterpieces.

Enter the world of AMG. Experience true driving performance.

**We don't just build cars.  
We make dreams come true.**





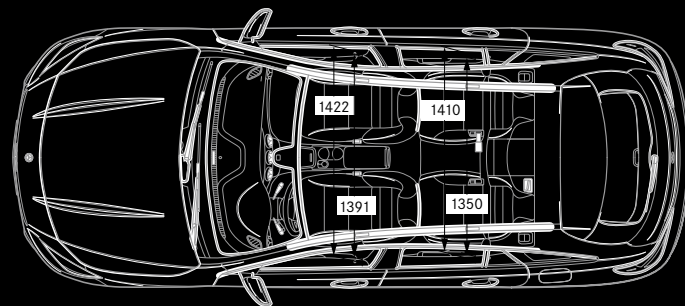
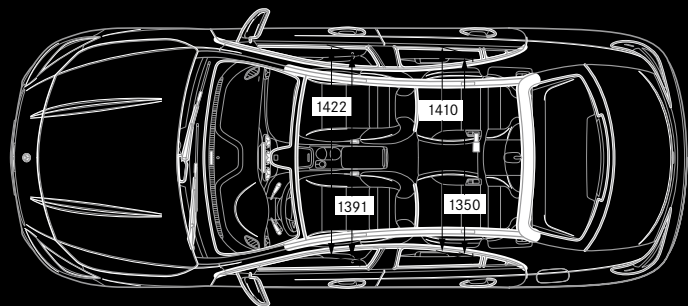
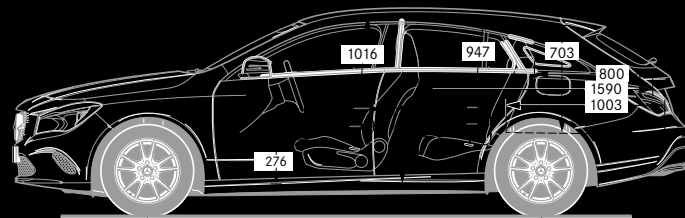
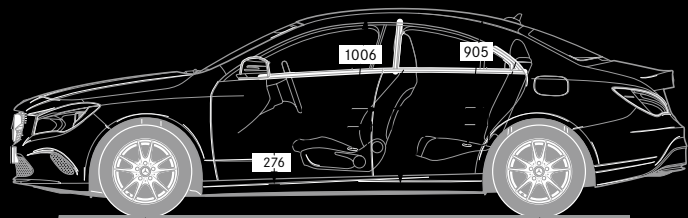
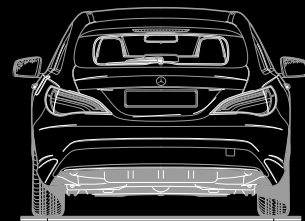
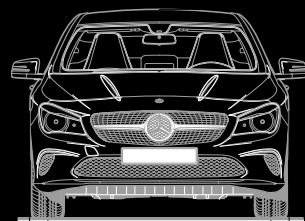
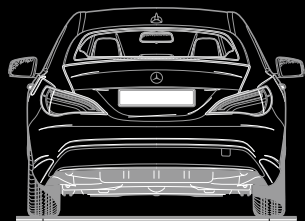
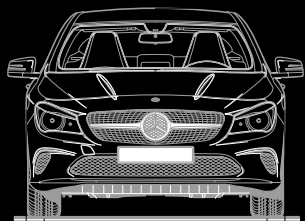



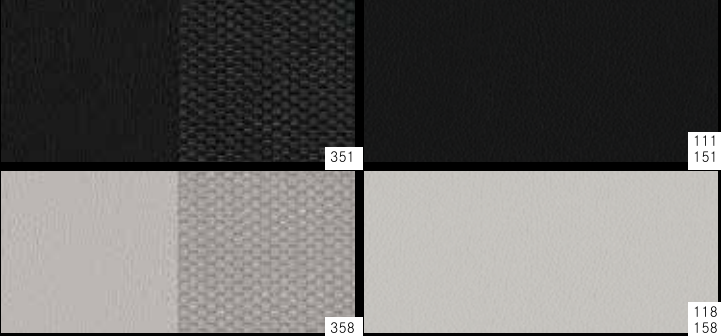

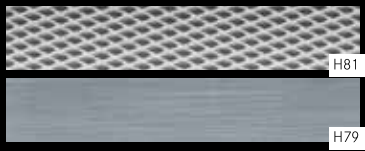
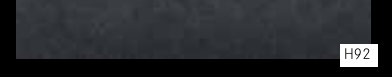
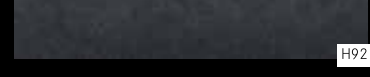
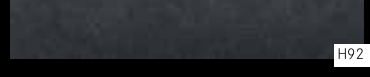
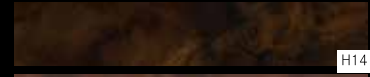
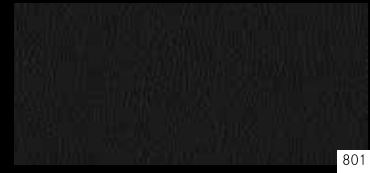



149



191



890

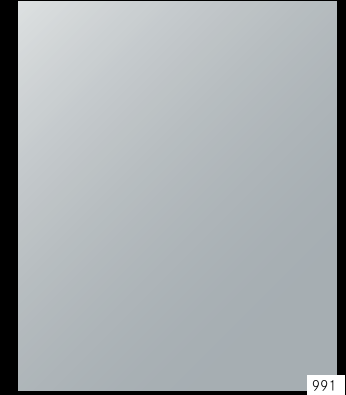

991



589



761



990



696



787



**Mercedes-Benz is one of the founding partners of the “Laureus Sport for Good Foundation”.**

Since the foundation was established in 2000, Mercedes-Benz has been supporting and promoting the aims and values of this worldwide non-profit-making programme: to use social sports projects to improve the lives of children and young people who are disadvantaged or suffering from illness. Laureus has become a fundamental element of Mercedes-Benz’s social responsibility. Every new Mercedes is an ambassador embodying these values. In buying a Mercedes you are supporting the “Laureus Sport for Good Foundation”.

**Please note:** changes may have been made to the product since going to press (04.07.2017). The manufacturer reserves the right during the delivery period to make changes to the design, form, colour or specification, provided these changes, while taking into account the interests of the vendor, can be deemed reasonable with respect to the purchaser. Where the vendor or the manufacturer uses symbols or numbers to describe an order or the subject of an order, no rights may be derived solely from these. The illustrations may include accessories and optional extras which do not form part of the standard specification. Actual colours may differ slightly from those shown owing to the limitations of the printing process. This brochure is distributed internationally. Information given regarding statutory regulations, legal requirements and taxation and the consequences thereof applies to the Federal Republic of Germany only and is correct at the time of going to print. For current and more specific information in relation to the range of models, features, optional extras, colours and/or services available in your country, and their pricing, you should contact your nearest authorised Mercedes-Benz Passenger Car Dealer.

[www.mercedes-benz.com](http://www.mercedes-benz.com)

Daimler AG, Mercedesstr. 137, 70327 Stuttgart, [dialog@daimler.com](mailto:dialog@daimler.com), 6701 · 1705 · 02-02/1217

**Take-back of end-of-life vehicles.** In due course you can return your CLA to us for environment-friendly disposal in accordance with the European Union (EU) End-Of-Life Vehicle Directive. But that day lies a long way off.

A network of vehicle take-back depots and dismantlers is available to make returning your vehicle as easy as possible for you. You are welcome to return your vehicle to one of these establishments free of charge. In so doing, you will be making a valuable contribution towards closing the recycling loop and preserving resources.

For further information about the recycling and disposal of end-of-life vehicles and take-back conditions, please visit your national Mercedes-Benz website.