

The C-Class Sedan



Mercedes-Benz





Never stop improving.

It is not about being better than others. It is about getting better than you are. That is what counts. In sport as well as on the road. The C-Class is known for its perfect proportions, its comfort, its quality and its drive: to exceed itself every day, on every journey, over and over again.



On top form,
when it matters.





The sense of forward momentum in the new C-Class Sedan is plain to see: the modified front end simply exudes dynamism and contemporary appeal. Depending on the precise specification, it features redesigned bumpers, gleaming chrome trim and stunning new LED headlamps.



23.0°C

16:50

0 km/h

470 km

1/2

Sportlich

Klassisch

Progressiv

e-Force

0

100

16:50

Bedien

NAVI



When it all feels perfect,
there can only be one objective:
to make it even better.

Perfect training conditions await you in the new C-Class Sedan: the new steering wheel with Touch Control buttons along with, depending on the precise specification, fully digital instruments and larger displays including a new-generation multi-media system, are state-of-the-art features that make operating the car a highly individual affair.

Sportiness,
redefined and refined.





The sensual purity of the design of the new C-Class Sedan is enough to cast the casual observer into transports of delight. In the case of our designers, it simply motivates them to optimise it further. A new lighting concept, new aprons, new colours and new materials add up to an even greater sense of the C-Class's hallmark dynamism and contemporary appeal.

It puts the most pressure
on itself. Electric.



Switch from a sedan to a sports car at the mere touch of a button. You can tune the optional DYNAMIC BODY CONTROL adjustable suspension yourself, to anywhere between decidedly comfortable and sportingly firm. The perfect complement to this is a new petrol engine with EQ Boost, already poised in the starting blocks. An electric starter-generator produces additional torque, among other things: the so-called “boost effect”.



Experience a level of comfort that means more: that relaxes and calms, yet also activates and stimulates. Very conveniently, at the touch of a button: thanks to the option of ENERGIZING Comfort Control. A highlight in the interior of the new C-Class.



Mercedes-Benz Intelligent Drive.

Be it during the rush hour, on long night-time journeys or on unfamiliar routes. Your new Mercedes-Benz C-Class Sedan provides tangible relief in stressful situations. It's all down to a concept that makes every journey in a Mercedes-Benz such a safe and exceptional experience: Mercedes-Benz Intelligent Drive. Because the time you spend behind the wheel is your time. Time for relaxation. Time to replenish your energy. So that, first and foremost, you reach your destination safely, but are also always relaxed when you get there.



ENERGISING COMFORT AND EXEMPLARY SAFETY

Driving Assistance Plus package: a new generation of stereo cameras and radar sensors enables a high level of driving assistance. Helpful for maintaining speed or distance as well as for automated braking or keeping in lane.

Particularly innovative: **PRE-SAFE® Sound** can generate a noise from the loudspeakers that triggers a protective reflex. The auditory system briefly disconnects, thus protecting itself from the loud noises of the crash.

The **360-degree camera** shows the surroundings of the vehicle in full on the multimedia system display.

Various safety systems and features included in Mercedes-Benz vehicles are driver assistance aids only and the driver at all times remains solely responsible for maintaining proper control of the vehicle, ensuring safety and monitoring the driving environment and complying with all applicable road rules.



Digital cockpit.

Smartphone Integration connects the mobile phone with the media system via Apple CarPlay™ or Android Auto™, thus providing convenient access to the most important applications of your smartphone. It also allows quick and easy use of apps from third-party service providers such as Spotify®.



YOUR GATEWAY TO THE DIGITAL WORLD OF MERCEDES-BENZ

The **fully digital instrument display** with the display styles “Classic”, “Progressive” and “Sporty” enables you to decide which information is important to you and how you wish to see it displayed. The 31.2 cm (12.3-inch) display delivers a pin-sharp image which is very easy to read in all light conditions.

The **high-resolution media display** in a 16:9 format with 10.25-inch screen diagonal adds a particularly high-quality touch to the interior of your vehicle. Thanks to the higher resolution of 1920 x 720 pixels you can enjoy brilliant image quality with crisp presentation of all infotainment content.

Wireless charging system for mobile devices: driving time becomes charging time – with just a simple hand movement your smartphone can be fixed in place in the centre console where it is charged wirelessly. Irrespective of the model and brand, all smartphones supporting the Qi standard are charged wirelessly.

Wireless charging feature only compatible with devices that support the Qi standard . Check the compatibility of your device and vehicle in Australia at www.mercedes-benz.com with your device manufacturer.



Head-up display.

The head-up display transforms the windscreen into a digital cockpit. As such, you always have key information in view and at the same time are able to maintain your full attention on the road ahead. For a focused and sporty driving experience.

Burmester® surround sound system.

Surround sound and superb tone in all seats: the Burmester® surround sound system offers music lovers an amazing listening experience. The overall sound pattern can be individually set to suit your own personal preference and the type of music being played – allowing you to enjoy exceptional quality at almost concert-hall level.



Ambient lighting.

Set the mood in the interior to suit your personal preference or current frame of mind. With a total of 64 colours to play with, the ambient lighting system offers almost unlimited opportunities to set the lighting mood, with the right colour to suit any situation.



Panoramic sliding roof.

Whether open or closed: with the panoramic sliding sunroof you can experience an amazing sense of freedom and enjoy a light and airy atmosphere in the interior. Seen from the outside, too, the generously proportioned sliding sunroof has a unique effect, giving the exterior an air of lightness and exclusivity.

Standard equipment and appointments.

The exterior of the car in its standard guise is already stunning from any angle. The focus lies on the harmonious interplay of the various design elements – resulting in a stylish overall impression with a hint of sportiness. If you opt for the standard-specification interior you are investing in timeless appeal. Flowing lines, sombre elegance and gentle contrasts add up to a puristic overall impression, offering a new interpretation of modern luxury. The partially power-adjustable standard seats offer excellent seating comfort – even on long journeys.



The AVANTGARDE equipment line.

With the AVANTGARDE exterior you can emphasise the individuality of your vehicle – and demonstrate the appeal of contemporary sportiness. The outcome of the interplay between the various design elements is an extraordinarily expressive vehicle. The lowered suspension offers the ideal balance between dynamism, comfort and safety. The AVANTGARDE interior allows you to show what matters to you: stylish sportiness, characterful individuality and top-class quality. With the Interior Lighting package, the merits of the interior can be seen even more clearly.



The EXCLUSIVE equipment line.

Use the EXCLUSIVE exterior to emphasise the elegance of your vehicle – and demonstrate once and for all how important style and quality are to you. The various design elements interact to convey a particularly elegant overall impression. The EXCLUSIVE interior allows you to show what matters to you: the utmost in elegance and top-class quality down to the most minute detail. The little luxury highlights and the refined ambience of your interior will continue to delight you each day anew. With the Interior Lighting package, the merits of the interior can be seen even more clearly.



The AMG Line.

The expressive styling of the AMG Line lends the exterior of the C-Class a sporty, exclusive touch. As such you can make a clear statement for powerful design. On top of this, the technical features give you palpably more fun at the wheel, since the agile configuration of the suspension with Sports Direct-Steer makes the handling noticeably dynamic. The AMG Line interior adds to the vehicle's sportiness, both visibly and tangibly. With it, you make a clear statement and show immediately what matters to you: an ambience that is dynamic and exclusive in every single detail.





DYNAMIC BODY CONTROL.

One suspension – three possible set-ups: with DYNAMIC BODY CONTROL, you can choose between maximum agility and high damping comfort. To match the route and your personal driving style. The low suspension level and the Sports Direct-Steer system provide you with the ideal conditions for a particularly dynamic driving style. The DYNAMIC BODY CONTROL suspension is equipped with continuously adjustable damping for both the front and rear axle. The stepless system interacts with the engine, transmission and steering characteristics to control the damping individually for each wheel – matched to the driving situation, vehicle speed and road surface. This variable configuration allows you to benefit from superb travelling comfort and outstanding driving dynamics.

FURTHER HIGHLIGHTS

It's possible to switch between a sporty and a comfortable configuration at the simple touch of a button, courtesy of the **DYNAMIC SELECT** switch in conjunction with one or other of the two available suspensions, DYNAMIC BODY CONTROL and AIR BODY CONTROL.



4MATIC all-wheel drive for C 43.

In city traffic, on country roads or on the motorway: with the permanent all-wheel drive system from Mercedes-Benz you will always feel safe on the road. The system improves traction when pulling away or accelerating, especially on a poor road surface. This is made possible by the perfect interplay between the 4MATIC system* and the electronic

braking, control and traction systems ABS, ESP® and 4ETS. The all-wheel drive system is constantly active and does not require any reaction time before intervening. Particularly on wet, snowy or icy roads, the improvement in driving and tracking stability is quite noticeable.

* Available on C43 only

No compromises.

Every Mercedes-AMG is a masterpiece in its own right, with an unmistakable character. What unites our performance vehicles and sports cars is their irrepressible sporting spirit. Their passion for top performance. It is generated at the point where engineering skill meets a very special attitude: the spirit of AMG. We believe that you have to keep on challenging limits in order to achieve new goals. We accept nothing as a given. Because limits are imposed by people, and it's also people who can overcome them. It's this attitude that enables us to achieve outstanding performance for the race track – and for the road.

Welcome to the world of AMG.

www.mercedes-amg.com

AMG
DRIVING PERFORMANCE





Technical data.

	Diesel engine	Petrol engines			
	C 220 d	C 200	C 300	C 43	C 63 S
Displacement (cc)	1950	1497	1991	2996	3982
Rated output (kW [hp] at rpm)	143 [194]	135 [184]	190 [258]	287 [390]	375 [510]
Acceleration 0-100 km/h (sec.)	6.9s	7.7s	5.9s	4.7s	4.1s
Top speed (km/h)	240 km/h	239 km/h	250 km/h	250 km/h	250 km/h
Fuel consumption (l/100 km)					
Urban	5.5	8.4	TBA	13.1	14.2
Extra-urban	4.1	5.2	TBA	7.2	8.1
Combined	4.7	6.4	TBA	9.4	10.4
Combined CO emissions (g/km)	122	145	TBA	214	237

The best for the engine:
Mercedes-Benz genuine engine oils.

The declared fuel and energy consumption figures are determined by testing under standard laboratory conditions to comply with ADR 81/02. Real world fuel consumption is influenced by many additional factors such as fuel quality, individual driving style, load, traffic, and vehicle condition. The declared fuel consumption figure should only be used for the purpose of comparison amongst vehicles. For more technical data, please visit www.mercedes-benz.com.au

Dimensions.

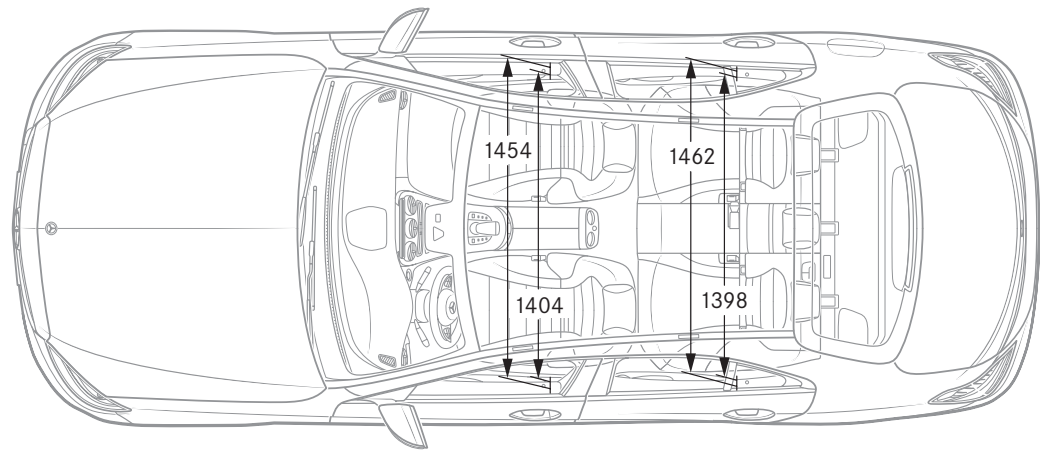
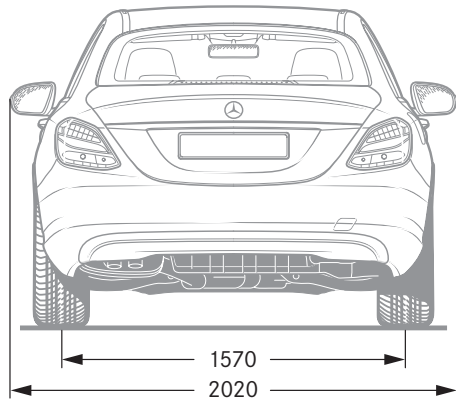
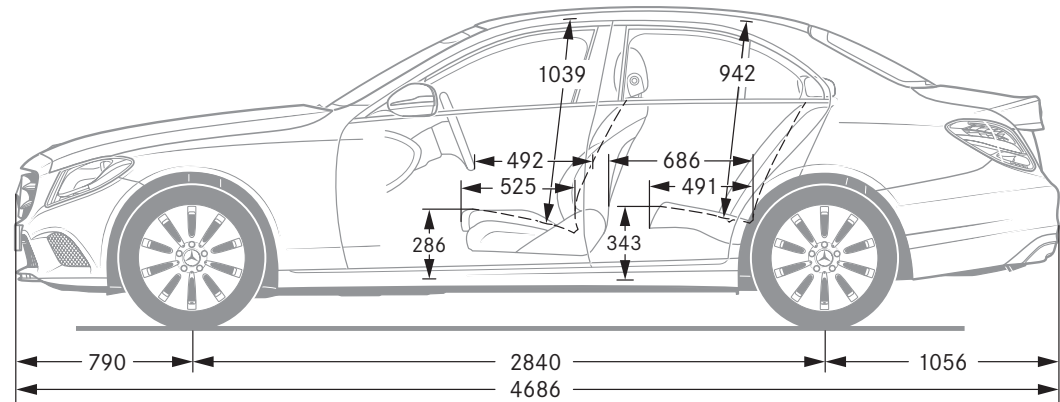
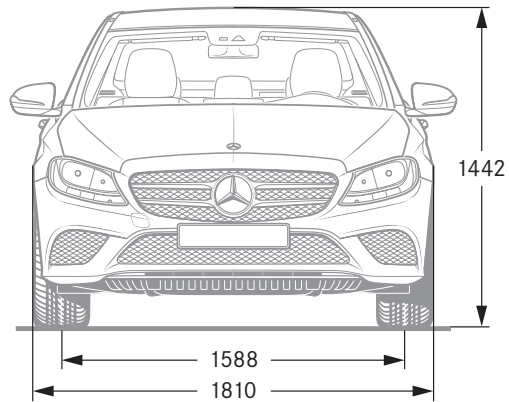

All figures in millimetres. The illustrated dimensions are mean values. They are valid for vehicles in basic specification and in unladen condition.



SPORT — F O R — GOOD

Mercedes-Benz is one of the founding partners of the “Laureus Sport for Good Foundation”.

Since the foundation was established in 2000, Mercedes-Benz has been supporting and promoting the aims and values of this worldwide non-profit-making programme: to use social sports projects to improve the lives of children and young people who are disadvantaged or suffering from illness. Laureus has become a fundamental element of Mercedes-Benz’s social responsibility. Every new Mercedes is an ambassador embodying these values. In buying a Mercedes you are supporting the “Laureus Sport for Good Foundation”.

Please note: changes may have been made to the product since the editorial deadline (13.07.2018). The manufacturer reserves the right to make changes to the design, form, colour and the product specification during the delivery period, provided these changes, while taking into account the interests of the vendor, can be deemed reasonable with respect to the purchaser.

The illustrations may show accessories and items of optional equipment which are not part of standard specification. This publication is distributed internationally. For the latest information regarding the regulations and implications in other countries, please contact your nearest authorised Mercedes-Benz dealer. www.mercedes-benz.com.au