

HiLux

Unbreakable



toyota.com.au



There's a spirit that runs through Toyota. It's a feeling of achievement. It pushes us. Inspires us.

— It's what saw us mass produce the first dedicated hydrogen fuel cell vehicle, the Mirai, and what will see us define the very future of movement. Our Japanese founders called it 'Kaizen,' but we simply call it 'continuous improvement.' A relentlessness to always move forward, never settle for good enough.

And here's the exciting part, this feeling of achievement is yours to experience. Life changing moments, just waiting to be told. Whether it's the thrill of experiencing the latest in technology, venturing somewhere completely new or simply spending more time with your family. That sense of achievement, whatever form it comes in, will be a feeling you never forget.

This is a journey for which we don't know the destination, but looking back at how far we've come, it's safe to say tomorrow looks exciting beyond imagination.

“

We are a group of passionate perfectionists who can't let well enough alone...

That's Toyota.

That's the spirit.

And that's our contribution to the world. We will be the best we can.

And we will help as many as we can to be the best they can...

— Eiji Toyoda

Developed the way the locals like it

There's no place on earth like Australia.
Big, beautiful, yet brutal and unforgiving.

Which is precisely why we used our local design
and engineering team to push the boundaries of
strength and redefine the legendary HiLux.

The result – HiLux Rogue, HiLux Rugged and
HiLux Rugged X. Developed locally and tailored
to the unique demands of Australian guests, the
trio boast a range of serious features that add
new levels of strength, attitude and capability.

Built to exceptional standards and tested
locally to ensure they withstand the harshest
of Australian conditions, these models come
backed by Toyota's new vehicle warranty.¹

Wherever you're headed, we're ready to
push the boundaries with you.

It's time to Awaken your Unbreakable.



All the strength you could ever need

The nation's favourite WorkHorse is built to be stronger than you could ever imagine.

Every HiLux begins with an uncompromisingly tough and proven DNA that's the result of over 40 years of continuous testing and development by Toyota in the harshest Australian conditions and terrain. Each is built from the ground up, starting with an extra strong high tensile steel frame featuring hundreds of spot welds to deliver a muscled-up body with exceptional strength and torsional rigidity. Together they mean

HiLux is primed to perform in the toughest real world situations.

Further building on the HiLux tradition of go-anywhere functionality, the locally developed HiLux Rogue, Rugged and Rugged X are more capable than ever, while delivering the next level of refined features and appointments to enjoy every action and adventure.

With such enduring strength and soul built into each and every HiLux, anything is possible.



4x4 Rugged Double-Cab Pick-Up in Glacier White. 4x4 Rugged X Double-Cab Pick-Up in Inferno.²
4x4 Rogue Double-Cab Pick-Up in Silver Sky.² 4x4 SR5 Double-Cab Pick-Up in Graphite.²

A statement in style and strength

With its wide stance and imposing presence, HiLux looks every part the powerful all-rounder.

Purposely designed to make it easier to load and handle the hardest jobs, then be more than welcoming when it's time to head out on the town.

From the boldly pronounced bumpers and striking grille designs, through to the dynamic running lines and muscular integrated wheel arch flares on wide body models, HiLux presents the modern portrait of workable strength.

Up ahead, halogen headlamps and Daytime Running Lamps (DRLs) show the way on WorkMate, SR and Rugged models, rising to LED low beam headlamps with halogen high beam and LED Daytime Running Lamps on SR5, Rogue and Rugged X. Plus the fully integrated LED light bar and spread beam driving lights on the Rugged X are designed to deliver an optimal spread of brightness for maximum visibility.

Depending on the demands of your crew, you can choose from Single-Cab, Extra-Cab or Double-Cab body types in a mix of 4x2 and 4x4 configurations that add up to 36 variants in the HiLux range. Step into the Hi-Rider, and you'll appreciate the increased height and underbody protection of a 4x4 with the everyday simplicity of a 4x2, while all Extra-Cab models have the added functionality of easy opening rear access doors.





4x4 SR5 Double-Cab turbo diesel automatic interior shown

Style more than skin deep

Even with such a defined strength outside, HiLux provides superb levels of interior style within. You could easily mistake the interior for a well-appointed SUV rather than a hard as nails WorkHorse.

Such accomplished levels of interior style and advanced technology features are matched with a superior ride quality and enhanced quietness to deliver a welcoming experience across the entire HiLux range. In Rogue and Rugged X models, the comfort of a leather accented interior provides a premium contrast to the well-muscled exterior.

Inside you'll always be cool on even the hottest days, with air conditioning fitted as standard on every HiLux. This rises to automatic climate control in SR5, Rogue and Rugged X models. Plus the smart entry and start system on these models allows you to get in and get going while the key stays in your pocket.

When it comes to great sound, the AM/FM colour touchscreen display audio system with CD player, USB,³ AUX³ and Bluetooth^{®4} connectivity is sure to keep you rocking, rising to 6 speaker sound in Double-Cab models (excluding WorkMate Double-Cab).

Once underway, the 4.2" Multi Information Display (MID) on SR5, Rogue and Rugged X models provides important trip and vehicle information including outside temperature and average fuel consumption levels. And to help you go straight to your next destination with ease, these models also include an integrated satellite navigation⁵ unit.



- A. Front air conditioned cooler box** – Excludes WorkMate models. SR5 shown
- B. Satellite navigation⁵** – Excludes WorkMate and optional on selected SR models. SR5 shown
- C. Automatic climate control** – SR5, Rogue and Rugged X only. SR5 shown
- D. 60/40 split fold rear seats** – SR, SR5, Rogue, Rugged and Rugged X Double-Cab only. SR5 shown
- E. Engine start stop button** – SR5, Rogue and Rugged X only. SR5 shown

Off-road or on the job, HiLux is up to the task

Every HiLux has been specially developed and tuned to handle the demands of Australian roads, whether they're in town or well off the beaten track.

The underbody protection on all Hi-Rider and 4x4 variants is built to be strong and durable. The special anti-corrosion undercoating makes it ready to meet the demands of harsh working environments, and the extra thick construction is perfect to handle and help deflect loose debris to add an extra level of serious self-defence.

The suspension has been tested and configured in Australia to ensure impressive off-road performance in even the harshest conditions.

An approach angle of up to 31° and departure angle of up to 26° on selected 4x4 variants means that HiLux will go further when the terrain gets tricky. And with incredible ground clearance and a transfer switch that allows you to quickly balance the drive to suit the conditions, you'll be able to comfortably tackle Australia's toughest terrain.

Hill-start Assist Control⁶ (HAC) automatically applies the brakes on steep slopes to help prevent rollback when starting to move forward. On slippery or uneven surfaces, Active Traction Control (A-TRAC) on 4x4 models optimally delivers the drive force to the wheels with the best grip to provide outstanding ground covering capability. On all 4x4 Double-Cab automatic models (excluding WorkMate), SR5 and Rugged X manual models, and SR5 Extra-Cab, Downhill Assist Control⁷ (DAC) automatically maintains low speed control when driving down steep, slippery and bumpy slopes.

Then when it's time to take charge of a heavy load, the HiLux braked towing capacity⁸ is up to an impressive 3.5 tonnes on selected turbo diesel 4x4 manual variants, even in off-road conditions, while the 4x2 WorkMate Single-Cab turbo diesel can shoulder up to a hefty 1,240kg payload with ease.

Honed, toned and ready to go, HiLux is ready for any challenge, whether it's a hard day's work or your next great adventure.

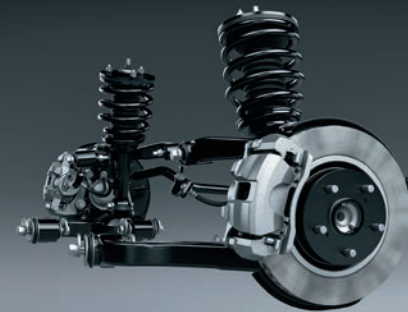

Front double-wishbone – 4x2 suspension shown

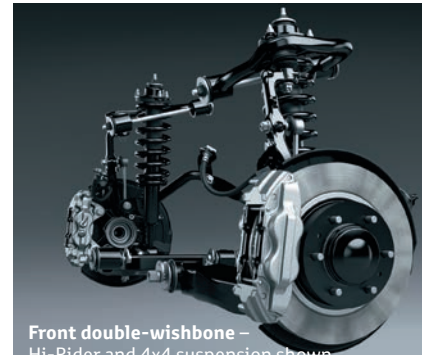

Front double-wishbone – Hi-Rider and 4x4 suspension shown



Heavy-duty rear leaf suspension – Hi-Rider and 4x4 suspension shown

Without Hill-start Assist Control



Hill-start Assist Control⁶ (HAC)

With Hill-start Assist Control⁶

Without Downhill Assist Control



Downhill Assist Control⁷ (DAC) is available on SR, SR5, Rogue, Rugged X, Rugged X 4x4 Double Cab and Rugged X SR5 and Rugged X manual models and SR5 Extra-Cab.

With Downhill Assist Control⁷

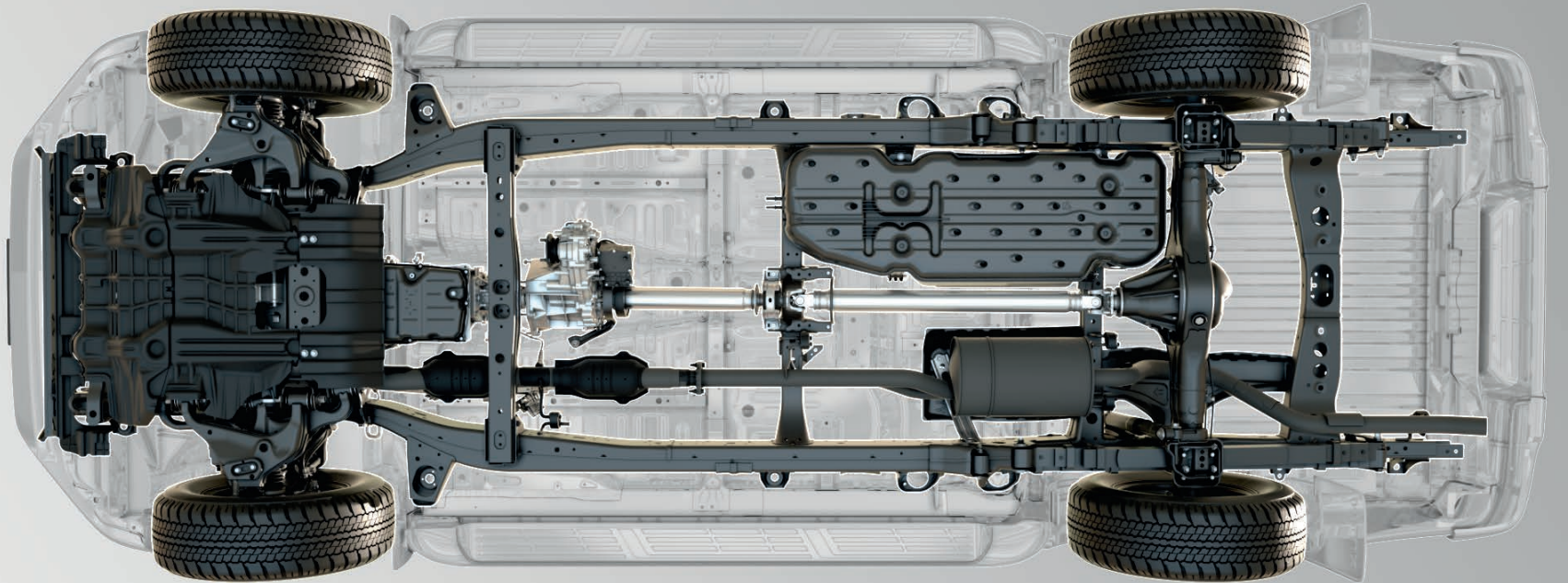

Hi-Rider and 4x4 underbody protection

Simply brilliant power



2.8L turbo diesel engine

Whatever the situation demands, with HiLux you'll always have the power to get the job done.

The 2.4L turbo diesel is available on HiLux WorkMate and delivers up to an impressive 400Nm⁹ of torque on automatic models.

On automatic SR, SR5, Rogue and Rugged models, the 2.8L turbo diesel pumps out an awesome 450Nm⁹ of pulling power, making this the strongest, most powerful turbo diesel HiLux engine. More than just numbers, this engine has been developed to produce the maximum torque at the lowest possible RPM. This means the power is always delivered smoothly, giving it outstanding driveability off-road or under load conditions. And it's then matched with a drive train that's engineered to deliver all that raw power intelligently.

If you prefer the power of a Dual VVT-i Petrol engine, the 2.7L version is available on the 4x2 WorkMate and delivers 122kW⁹ of power. On the 4x2 WorkMate Double-Cab

manual variant, the 2.4L turbo diesel engine delivers a thrifty fuel efficiency of 7.1L/100km¹⁰. Stepping up to the 2.8L turbo diesel still delivers an impressive fuel efficiency of 7.3L/100km¹⁰ on the 4x2 SR Double-Cab manual. Whilst the 2.7L petrol engine provides fuel economy as low as 10.7L/100km¹⁰ on the 4x2 WorkMate Double-Cab manual.

The intelligent Manual Transmission (i-MT) is standard on SR5 and Rugged X models. This technology refines manual gear selection by automatically setting the optimal engine revs to allow the smoothest possible gear changes, whether up or down, and helps avoid stalls in even the most critical situations.

On selected models you have the choice of a 6-speed automatic, 6-speed manual transmission or 5-speed manual transmission that have been optimised to provide the smoothest possible drive using gear ratios that make the best use of the available power in all conditions and ultimately place less stress on the engine.

The confidence of advanced safety

Whether you're heading to a job, or onto the open road, you'll have the peace of mind of knowing HiLux is equipped with an array of advanced safety features.

Seven SRS airbags, including side, curtain and a driver's knee airbag, are standard across the range. The reversing camera¹¹ is fitted standard on HiLux Pick-Up variants with a display that features static guidelines to help make reversing into tight spaces not only safer, but easier too.

The intelligent Anti-lock Braking System (ABS) with Electronic Brake-force Distribution (EBD) helps you stop quickly and safely, while Traction Control (TRC) and Vehicle Stability Control (VSC) help you maintain grip on slippery surfaces and help provide greater control when cornering.

3-point seatbelts with Emergency Locking Retractors (ELR) are standard on each seat, and seatbelt reminders are fitted to all front seats and rear seats in Double-Cab variants.

On all variants, Trailer Sway Control (TSC) automatically uses brake and engine output to help limit trailer movement should it experience excessive sway due to cross winds, variable road surface or steering changes by the driver.

- A. Seven SRS airbags** – Overseas model shown
- B. Anti-lock Braking System (ABS)**
- C. Trailer Sway Control (TSC)**
- D. Vehicle Stability Control (VSC)**
- E. Child restraint anchor** – Double-Cab only, SR shown



A.

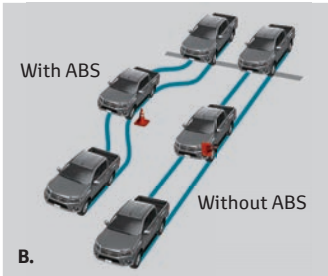

B.

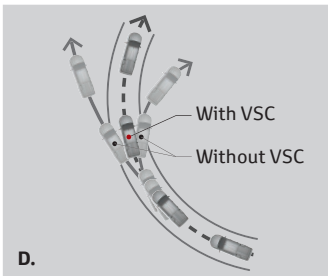

D.

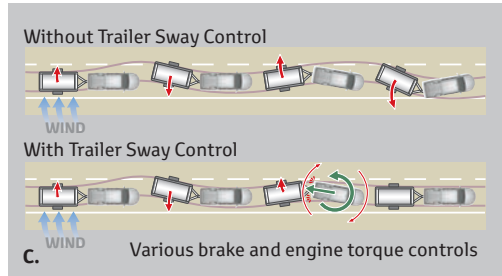

C.



E.

Awaken your Unbreakable



4x4 Rugged X Double-Cab Pick-Up in Inferno²

HiLux Rogue, Rugged and Rugged X models include a range of serious features that boost off-road protection, recovery and functionality to match your lifestyle and sense of adventure.

The functional sports bar features an impressive tie-down rating of up to 200kg, allowing you to secure items like your favourite dirt bike safely in the tray.

The tow bar is standard across all three models, and its braked towing capacity is rated up to a hefty 3,500kg on manual models and up to 3,200kg on automatic models, perfect for your favourite caravan or boat.⁸

The high tensile steel Toyota Genuine bullbars on Rugged models are designed to take on Australian conditions. On Rugged X, the winch compatible hoopless bullbar has a seamlessly integrated 120 watt LED light bar and outboard LED spread beam driving lights to provide maximum visibility and light up what's ahead and on either side of the road.

When off-roading, the front and rear recovery points on Rugged X and rear recovery points on Rugged are there to help when the going gets tough.¹²

The heavy duty rock rails on both Rugged models offer extra vehicle protection, and are strong enough to support a laden vehicle from underneath, should you make contact with rocks or hard surfaces when driving off-road. The 5mm thick, high strength alloy bash plate on the Rugged X adds another level of vehicle protection.

Together they add up to an extraordinary range of features, with extensive design and testing conducted by the local team in Australia.

- A. Hoopless steel front bullbar** – Rugged X only
- B. Functional sports bar** – Rogue, Rugged, Rugged X only
- C. Rock rails** – Rugged and Rugged X only
- D. Tow bar, tow ball and tongue** – Rogue, Rugged, Rugged X only
- E. Recovery points** – Rugged: rear only, Rugged X: front and rear

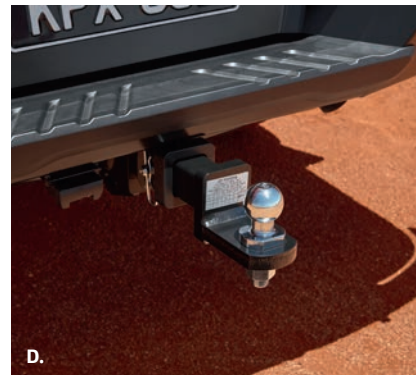

HiLux WorkMate



4x2 WorkMate Single-Cab Cab-Chassis in Glacier White shown with optional Toyota Genuine tray body. All accessories sold separately

4x4 WorkMate Extra-Cab Cab-Chassis in Silver Sky² shown with optional Toyota Genuine tray body. All accessories sold separately

The perfect companion to get the job done, with plenty of refinements when it's time to put the tools down.

- 2.7L petrol engine
- 2.4L turbo diesel engine
- 5-speed manual transmission – 4x2 only
- 6-speed manual transmission – 4x4 only
- 6-speed automatic transmission
- 4x2 and 4x4 drive train options
- Diesel Particulate Filter (forced burn off) switch – diesel engine only
- Steel wheels
- Raised suspension and underbody package – Hi-Rider and 4x4 only
- Automatic headlamps (light sensitive)
- Remote keyless entry
- Power windows
- Manual tilt steering column
- Manual telescopic steering column – excludes 4x2 Single-Cab
- Air conditioning
- Black electric side mirrors
- Halogen Daytime Running Lamps (DRLs)
- Rear defroster
- 12V accessory socket
- 6.1" colour touchscreen display
- Audio and telephone steering wheel switches
- 3.5mm AUX³ and USB³ input for portable audio players
- Front cup holders
- Small centre console bin
- Overhead console box
- Reversing camera¹¹ – Pick-Up only
- Emergency stop signal
- Seatbelt warning – not applicable to Extra-Cab rear seats



2.4L turbo diesel engine



Reversing camera¹¹
– Pick-Up only



Halogen headlamps



3.5mm AUX³ and USB³ input



Cup holders



Electric side mirrors – Extra-Cab shown

HiLux SR



Hi-Rider SR Extra-Cab Pick-Up in Olympia Red²
SR Single-Cab front face design differs from images shown

4x4 SR Double-Cab Cab-Chassis in Graphite² shown with optional Toyota Genuine tray body.
SR Single-Cab front face design differs from images shown. All accessories sold separately.

The HiLux that's ready to rise to any mission or occasion.

- 2.8L turbo diesel engine
- 6-speed manual transmission
- 6-speed automatic transmission
- 4x2 Hi-Rider and 4x4 drive train options
- Diesel particulate filter (forced burn off) switch
- Front air conditioned cooler box
- Rear differential lock – 4x4 only
- 60/40 rear seat (Tip up) – Double-Cab only
- Body coloured front bumper
- Side steps
- Halogen fog lamps – Extra-Cab and Double-Cab only
- Front personal lamp
- Premium fabric seats
- Durable vinyl floor covering
- 7" colour touchscreen display with Toyota Link¹³
- Multi Information Display (MID)
- Downhill Assist Control⁷ – 4x4 Double-Cab Pick-Up automatic only

Option pack: 17" alloy wheels, satellite navigation⁵ and digital radio¹⁴ and A-deck tray – 4x4 Double-Cab Pick-Up only



2.8L turbo diesel engine



Front air conditioned cooler box



60/40 split fold rear seat
- Double-Cab only



Side steps



Optional 17" alloy wheels
- 4x4 Double-Cab Pick-Up only

HiLux SR5



4x4 SR5 Extra-Cab Pick-Up in Nebula Blue²

4x4 SR5 Double-Cab Pick-Up in Eclipse Black²

The head turning HiLux that packs a powerful punch.

- 2.8L turbo diesel engine
- 6-speed intelligent Manual Transmission (i-MT)
- 6-speed automatic transmission
- 4x2 Hi-Rider and 4x4 drive train options
- 18" alloy wheels
- Diesel particulate filter (forced burn off) switch
- Smart entry and start system
- Integrated LED Daytime Running Lamps (DRLs)
- LED low beam headlamps with halogen high beam
- LED front fog lamps
- Automatic climate control
- 220V accessory socket – Double-Cab only
- Stainless steel sports bar
- Privacy glass
- Premium gear lever and steering wheel
- Alarm
- Tow bar receiver (tow ball, tongue and wiring harness sold separately)
- Chrome interior door handles
- 4.2" colour Multi Information Display (MID)
- Satellite navigation⁵
- Downhill Assist Control⁷ (DAC) – 4x4 only

Option pack: Leather accented interior, power adjustable driver's seat, driver and front passenger seat heater – 4x4 Double-Cab only



Smart start engine button



Satellite navigation⁵ and colour touchscreen display



LED headlamps



Automatic climate control



18" alloy wheels

HiLux Rogue



4x4 Rogue Double-Cab Pick-Up in Silver Sky²

When you want a little more refinement, HiLux Rogue is the supreme choice of comfort, capability and style.

- 2.8L turbo diesel engine
- 6-speed automatic transmission
- 4x4 drive train
- 18" Rogue alloy wheels
- Diesel particulate filter (forced burn off) switch
- Leather accented interior (perforated)
- Heated front seats
- 8-way power adjustable driver's seat
- Premium gear lever
- Rogue grille
- Black functional sports bar with recreational attachment points
- Hard tonneau cover with dust defence kit
- Marine grade carpet tub liner
- Gloss black door trim and mirror scalps
- Black door handles
- Tow bar, tow ball and tongue
- Trailer wiring harness (7 pin flat)
- Black tailgate handle and tailgate lock
- Carpet floor mats
- Rogue decals



Leather accented interior (perforated) with heated front seats



Rogue grille



Hard tonneau cover with dust defence kit



18" Rogue alloy wheels

HiLux Rugged



4x4 Rugged Double-Cab Pick-Up in Glacier White

Make an even stronger statement in style with the robust HiLux Rugged. Perfect for working hard and playing even harder.

- 2.8L turbo diesel engine
- 6-speed manual transmission
- 6-speed automatic transmission
- 4x4 drive train
- 17" Rugged alloy wheels
- Diesel particulate filter (forced burn off) switch
- Snorkel
- Rock rails
- Premium steel bullbar
- Rugged grille
- Heavy duty rear bumper
- Recovery points – rear¹²
- Black functional sports bar with recreational attachment points
- Body side mouldings
- Wheel arch mouldings
- Tow bar, tow ball and tongue
- Trailer wiring harness (7 pin flat)
- Black tailgate handle with tailgate protection
- All-weather floor mats
- Rugged decals
- Satellite navigation⁵
- Digital radio¹⁴



Snorkel



Black functional sports bar



Premium steel bullbar



Rock rails and body side mouldings



17" Rugged alloy wheels

HiLux Rugged X



4x4 Rugged X Double-Cab Pick-Up in Inferno²

An uncompromising combination of off-road capability and urban credibility, with premium strength and style. HiLux Rugged X is the ideal partner for your next adventure.

- 6-speed intelligent Manual Transmission (i-MT)
- 6-speed automatic transmission
- 4x4 drive train
- 17" Rugged alloy wheels
- Diesel particulate filter (forced burn off) switch
- Leather accented interior (perforated)
- Heated front seats
- 8-way power adjustable driver's seat
- Premium gear lever
- Snorkel
- Rock rails
- Hoopless steel front bullbar (winch compatible)
- Bash plate
- Rugged grille
- Heavy duty rear bumper
- LED light bar
- Spread beam driving lights
- Recovery points – front and rear¹²
- Black functional sports bar with recreational attachment points
- Body side mouldings
- Wheel arch mouldings
- Gloss black door trim and mirror scalps
- Black door handles
- Tow bar, tow ball and tongue
- Trailer wiring harness (7 pin flat)
- Black tailgate handle with tailgate protection
- All-weather floor mats



Tail lamp garnish



Rugged decals



Front (shown) and rear recovery points



Hoopless steel front bullbar, LED light bar and spread beam driving lights



Bash plate



WorkMate Single-Cab shown

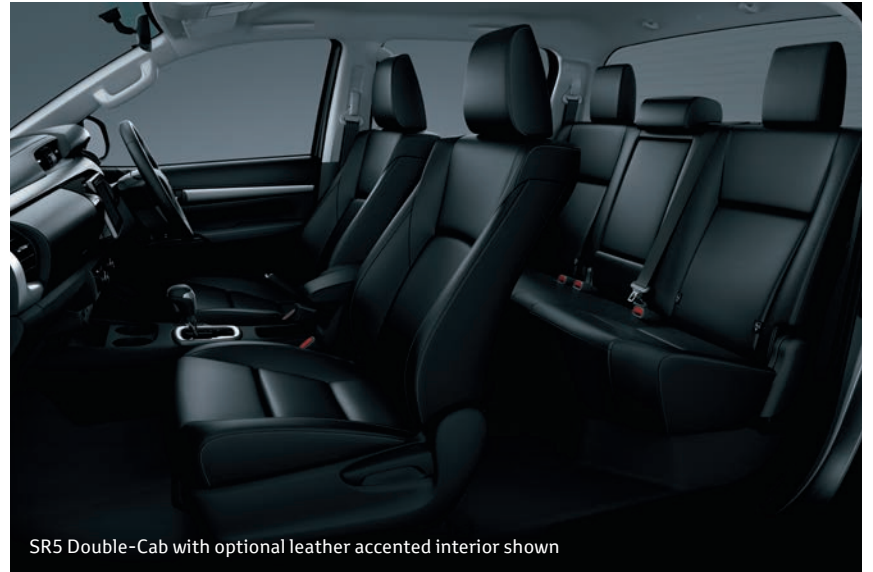

SR5 Double-Cab with optional leather accented interior shown



SR Extra-Cab shown

Smart thinking throughout

With so much strength on display outside, you'll be surprised to find HiLux is so plush within. Step inside and you'll find yourself comfortably surrounded by the ergonomic appeal of well thought out interior space. Everything is where it should be, in easy reach and easy to use. There's also a surprising collection of handy pockets and compartments to store your essentials such as sunglasses, work gear and clothes.

On SR models or higher, the air-conditioned cooler box is perfect for keeping your lunch or refreshments chilled. And the 220V accessory connector on Double-Cab SR5, Rogue and Rugged X models is ideal to charge your laptop or phone on the go.

Tough any way you want it

Only Toyota Genuine Accessories¹⁸ are designed to be the perfect fit for your HiLux, with some Accessories developed in conjunction with the vehicle up to 5 years before launch. They're built to take 'Unbreakable' to the next level. Accessorise your HiLux to suit your lifestyle with a huge range to choose from.

To find out more, go to toyota.com.au/hilux



Premium steel bullbar (Fog lamps version shown)



Commercial steel bullbar

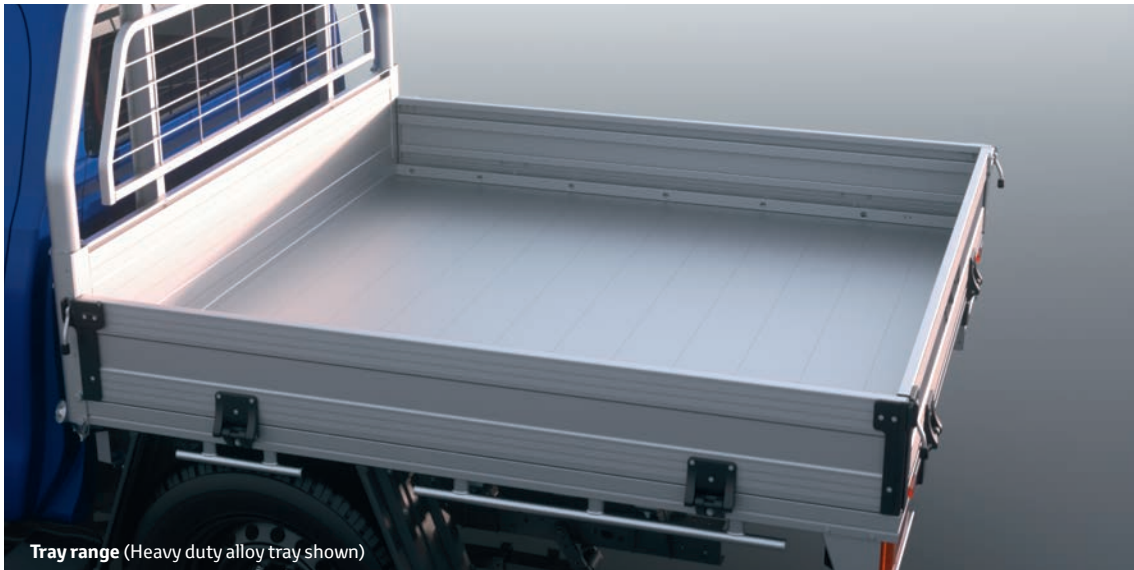

Tray range (Heavy duty alloy tray shown)

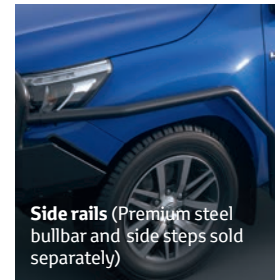

Side rails (Premium steel bullbar and side steps sold separately)

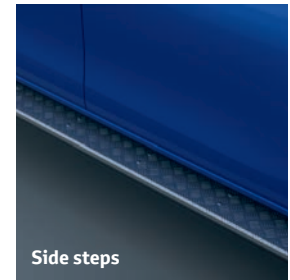

Side steps

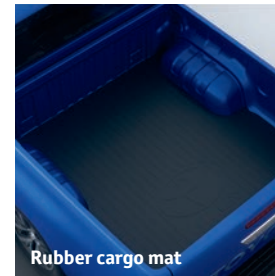

Rubber cargo mat

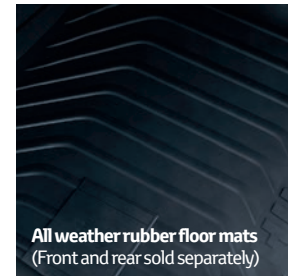

All weather rubber floor mats (Front and rear sold separately)



4x4 SR Extra-Cab Cab-Chassis turbo diesel in Eclipse Black^{2,4,5} shown accessorised with premium steel bullbar, 18" alloy wheels (matte black), heavy duty steel tray body, side steps, side rails, bonnet protector, headlamp covers and weathershields. All accessories sold separately



4x4 SR5 Double-Cab Pick-Up turbo diesel in Nebula Blue^{2,15} shown accessorised with alloy bullbar, 18" alloy wheels (grey), driving lights, tinted bonnet protector, headlamp covers, weathershields, snorkel, roof racks and hard tonneau cover. Driving light harness and bracket required for fitment of driving lights. All accessories sold separately



Alloy bullbar (Fog lamp compatible version shown)



Canopy



Nudge bar



Snorkel



Hard tonneau cover



18" alloy wheel
(Shown in matte black)

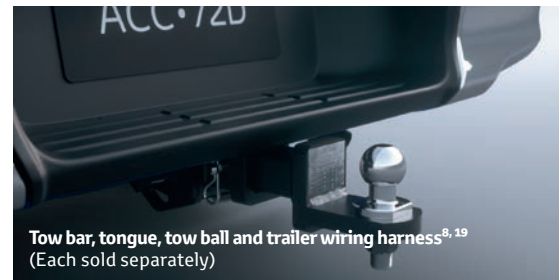

Tow bar, tongue, tow ball and trailer wiring harness^{8, 19}
(Each sold separately)



Soft tonneau cover



Dash camera

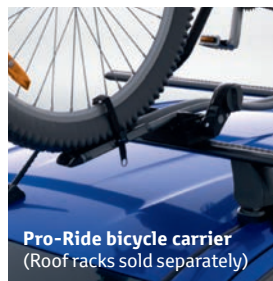

Pro-Ride bicycle carrier
(Roof racks sold separately)



Roof racks



The Toyota Advantage

Every Toyota gives you a lifetime of advantages. That's what makes it a Toyota. You'll enjoy legendary Toyota value from the moment you drive away, and you'll continue to appreciate the quality, safety and innovation that's engineered into each model, every day you drive.

Discover the full range of products and services and find your nearest Dealer at toyota.com.au

Discover the freedom of Toyota Access²⁰

Toyota Access puts you in complete control when buying a new car, with lower monthly repayments.²¹ Drive out of the Dealership with a clear road ahead then drive back a few years later with more options at your disposal than ever before. Whatever stage you're at in life, Toyota Access puts you in the driver's seat with flexibility and assurance. To discover Toyota Access for yourself visit toyota.com.au/access

Capped price servicing²²

A new Toyota means you don't have to worry about unexpected service costs. Every Toyota comes with a low, capped price service cost for a set number of years/kilometres. Pay the same low capped price from one eligible logbook service to the next for up to three years or 60,000km, whichever occurs first (including Genuine parts, labour and fluids). For the full benefits consult a Toyota Dealer or visit toyota.com.au/advantage

We've got your back

Every new Toyota is built to exceptional standards, backed by a three year/100,000km warranty,²³ giving you the peace of mind to feel confident for years to come. In the unlikely event that you need them, every Toyota Service Centre is committed to providing any warranty repairs you may need. They have the technology, the tools, and the skilled personnel to keep your Toyota in excellent condition.

Finance to get you going

If you need a little help, Toyota Finance²⁴ can offer you a wide range of vehicle financing options. With Toyota Finance, you'll have the peace of mind of dealing with one of Australia's leading vehicle finance corporations with over 30 years experience. And with a range of flexible products and services to suit almost every need and circumstance, Toyota Finance can help find the right package for you or your business.

Insurance options

Our Comprehensive Motor Vehicle insurance policy is packed with great benefits including; agreed value cover, new vehicle replacement if your Toyota is written off within the first three years, use of Toyota Genuine Parts, and a Lifetime Repair Guarantee on repairs authorised by Toyota Insurance.²⁵ And our Factory Approved Extended Warranty Insurance also provides benefits, for more information visit toyota.com.au/insurance

Extend your peace of mind

Whether it's a flat tyre, lost keys or a flat battery, Toyota Extra Care Roadside Assist²⁶ is never more than a phone call away. Available 24 hours a day, seven days a week, our technicians are there to help you get back on the road.

Disclaimers and Notice

- 1 New Vehicle Warranty expires three years from date of first delivery or 100,000km, whichever occurs first. Refer to warranty conditions at toyota.com.au/owners/warranty. The New Vehicle warranty does not limit and may not necessarily exceed your rights under the Competition and Consumer Act 2010.
- 2 Paint featured is an optional extra at additional cost.
- 3 Not all devices will be compatible. Functionality varies depending on device.
- 4 The Bluetooth® word mark is owned by Bluetooth SIG, Inc. Not all devices will be compatible and functionality varies depending on the device.
- 5 Current navigation mapping database encompasses major capital and primary national road networks and offers some coverage in regional areas.
- 6 Hill-start Assist Control is a Driver Assist Technology and should not be used as a substitute for safe driving practices. Driver remains responsible at all times for safe driving.
- 7 Downhill Assist Control is a Driver Assist technology and should not be used as a substitute for safe driving practices. Driver remains responsible at all times for safe driving.
- 8 Towing capacity is subject to regulatory requirements, tow bar and vehicle design and towing equipment limitations. Ask your Dealer for Toyota Genuine tow bar capacity and details. Please consider whether the item you wish to tow is within the vehicle's towing capacity.
- 9 Power and torque test standards differ. Ensure comparisons use same test standard.
- 10 Achieved in test conditions. Actual fuel consumption may vary depending on driving conditions/style, vehicle condition and options/accessories fitted. Fuel consumption data provided for comparison purposes only. Source: ADR81/02 combined.
- 11 Reversing camera is a driver assist feature only and not a substitute for safe driving practices. Driver remains responsible at all times for safe driving.
- 12 Use of recovery points has safety risks which need to be assessed and managed before every recovery operation. Incorrect use of the recovery points may result in death, serious injury or vehicle damage. Always following warnings and instructions provided on the vehicle and in the Owner's Manual.
- 13 Toyota Link is available on certain vehicle models and grades only. Toyota Link services rely on data from the driver's compatible mobile phone and information provided by third parties. Availability is dependent on a number of factors, including the availability of third party information, mobile service, sufficient mobile data allowance and GPS satellite signal reception. Mobile usage is at the user's cost. Toyota Australia reserves the right to add, remove or modify applications. Further information is provided at toyota.com.au/toyotalink
- 14 Digital radio station coverage dependent on vehicle location.
- 15 Toyota Australia reserves the right to vary and discontinue the current interior and exterior colours, trims and colour/trim/model combinations. Colours and trims displayed here are a guide only and may vary from actual colours due to printing/display process. See your Toyota dealer to confirm colour/trim/model availability when ordering your vehicle. Metallic/mica pearlescent paint is optional and subject to additional charges on most models.
- 16 Not available on Extra-Cab.
- 17 Not available on Single-Cab.
- 18 Toyota Genuine Accessories are not applicable to all models/grades. Consider the mass of your load to ensure you will not exceed the maximum allowable individual axle capacity, Gross Vehicle Mass and/or Gross Combined Mass of the vehicle. Refer to the current Accessories brochure or visit toyota.com.au for details on warranty and toyota.com.au/vehiclepayload for details on vehicle payload, to help determine Accessories suitable for your vehicle. Accessory colours shown may vary from actual colour due to the printing process.
- 19 Hilux SR5 models come fitted with a tow bar receiver as standard.
- 20 Terms and conditions, fees and charges apply. Toyota Access Guaranteed Future Value products are available to approved customers of Toyota Finance, a division of Toyota Finance Australia Limited ABN 48 002 435 181, AFSL and Australian Credit Licence 392536.
- 21 Lower monthly repayments compared to a similar term with no Guaranteed Future value (GFV) or equivalent balloon final payment. Total interest charges will be higher if a GFV or balloon final payment is selected.
- 22 Maximum payable for standard scheduled logbook servicing (normal operating conditions) until first of three years or 60,000km (whichever occurs first), up to the first six services. Excludes Government & Rental vehicles. Contact your Toyota Dealer or go to toyota.com.au/advantage for other exclusions, eligibility and full details.
- 23 New Vehicle Warranty expires three years from date of first delivery or 100,000km, whichever occurs first. Refer to the warranty conditions. The New Vehicle warranty does not limit and may not necessarily exceed your rights under the Competition and Consumer Act 2010.
- 24 Approved applicants only. Terms and conditions apply. Toyota Finance is a division of Toyota Finance Australia Limited ABN 48 002 435 181, AFSL and Australian Credit Licence 392536.
- 25 Terms and conditions apply. This advice is general in nature and does not take into account your objectives, financial situation or needs. Before making a decision to purchase any of the insurance products you should consider the appropriateness of the advice taking into account your own objectives, financial situation and needs and refer to the current PDS for the relevant product available from participating Dealers, via our website at toyota.com.au/insurance or by calling 137 200. Toyota Insurance purchased in a dealership or via the Toyota Insurance National Customer Solutions Centre is issued by Toyota Finance Australia Limited ABN 48 002 435 181, AFSL and Australian Credit Licence 392536. The insurer is Aioi Nissay Dowa Insurance Company Australia Pty Ltd ABN 11 132 524 282, AFSL 443540 (Adica). If Toyota Insurance is purchased online, the issuer and insurer is Adica. Our warranty insurance policies do not change or take away your rights under the Australian Consumer Law. Your right to claim under our warranty insurance policies for the benefits covered are in addition to other rights and remedies you have under the law in relation to your vehicle. However, you can choose to make a claim under any of our warranty insurance policies even if you have rights under the law.
- 26 Toyota Extra Care Roadside Assist is administered by Toyota Finance, a division of Toyota Finance Australia Limited ABN 48 002 435 181, AFSL and Australian Credit Licence 392536.

IMPORTANT NOTICE – PLEASE READ:

Toyota Australia uses its best endeavours to ensure this material is correct when published. You must check with your authorised Toyota Dealer when ordering to ensure the vehicle with your chosen specifications, equipment and colour is available and that the vehicle can be delivered within the timeframe suitable to you. When ordering accessories, you must check with your authorised Toyota Dealer to ensure the accessory's design, features and colours are available and will fit your vehicle. Ensure the mass of your load does not exceed the maximum allowable individual axle capacity, Gross Vehicle Mass and/or Gross Combined Mass of the vehicle. Refer to toyota.com.au/payload for further details. Colours displayed here are a guide only and may vary from actual colours due to printing/display processes. Certain accessories when fitted will require the removal of standard equipment. Standard equipment

may be retained by Toyota Australia. Toyota Australia reserves the right to change, without notice, at any time prices, colours, materials, equipment, specifications and discontinue colours/models. To the extent permitted by law, Toyota Australia will not be liable for any damage, loss or expense incurred as a result of reliance on this material in any way. Distributed nationally (other than in Western Australia) by Toyota Motor Corporation Australia Limited ABN 64 009 686 097, 155 Bertie St, Port Melbourne 3207. Material distributed in Western Australia by or on behalf of Prestige Motors Pty Ltd (for vehicles) and by Eastpoint Pty Ltd (for parts/accessories). Toyota Australia makes no warranties regarding (and will not be liable for) the accuracy of materials distributed in Western Australia. PART NUMBER: TYHILUXPACKBRO. PROOF: T2018-010372. GTO2004. VERSION: JANUARY 2019.