

The GLE

Sport Utility Vehicle



Mercedes-Benz



This Brochure is prepared by Mercedes-Benz Group AG and it predominantly reflects the capabilities and performance of vehicles sold in Europe. Some characteristics, capabilities, performance features and optional extras (e.g. towing systems) may not be available or may not apply in Australia or under Australian conditions. The information in this Brochure is therefore indicative, illustrative and provided only for guidance and should not be relied on. To obtain current and accurate information on a vehicle and any options applicable to Australia, contact your local authorised Mercedes-Benz retailer. The declared fuel and energy consumption figures are determined by testing under standardised laboratory conditions to comply with ADR 81/02. Real world fuel consumption is influenced by many additional factors such as fuel quality, individual driving style, load, traffic, and vehicle condition. The declared fuel consumption figure should only be used for the purpose of comparison amongst vehicles.

The shape of success. In a whole new dimension.

More intelligent and attentive than ever – the new GLE casts the SUV in a whole new light. Its suspension actively smooths out any unevenness and its infotainment system learns more about your preferences as the days go by. Its convenience systems, meanwhile, can recognise when you need to take a rest.





Consistency all down the line.

Take a step back at the right moment and then be right there when it matters the next moment – that is the art of the GLE design. The optional AMG Line and wheels up to 22 inches in size can make it distinctively sportier. This expression of clarity and dynamism is typical of Mercedes-Benz design today.

Follow your intuition.

The new GLE is the first SUV to feature the revolutionary MBUX infotainment system. Highlights here include a natural-language voice control system, a range of touch controls and the ability to learn more about the habits and preferences of the driver with each journey.





More space for inner greatness.

For the first time, the GLE is now optionally available with a third seat row with two full-size seats. Access to the third row is easy, while the flexibility provided by an adjustable second seat row makes the footwell very adaptable. And what's even better is that the improved spatial concept of the new GLE still provides more legroom and comfort in the rear.



The embodiment of calm.

Keeping things calm can sometimes take a lot of effort. Under tricky circumstances, it's something achieved by only a few people and only one SUV: the new GLE with optional E-ACTIVE BODY CONTROL fully active suspension. It is able to adapt in a split second to the road surface ahead.



The new GLE simply
oozes serenity.

Sensual surfaces, muscular contouring and clear lines define the design of the new GLE. It is hard to imagine a more elegant and dynamic expression of power.



AIRMATIC package.*

In the AIRMATIC package, an adaptive damping system meets modern air suspension. The result: an intelligent comfort suspension which is able to adjust automatically to the driving conditions, speed and load. As a result you benefit from counterbalancing driving stability with first-class comfort both on good and bad roads.



ENERGISING COACH.**

The new optional ENERGISING COACH can noticeably relax or invigorate the driver. For this purpose, it employs software which combines the data from a fitness tracker with various comfort systems in the vehicle.

*Standard equipment of the GLE 53. Available as optional equipment on all other variants.
**Available as optional equipment



Night Package.*

Added character – expressive style. In combination with the AMG Line, the optional Night Package adds striking highlights in the form of exclusive black design features. These accentuate the sporty character and athletic design idiom of your vehicle. Ideal for individualists with a true appreciation of expressive design.



Head-up display.

The best outlook for sporty driving enjoyment and an assured driving experience: the head-up display transforms your windscreen into a stunning digital cockpit. As such you always have a direct view of key information. Your full attention remains on the road and the traffic conditions in front of you.

*Not available on the GLE 53. Available as optional equipment on all other variants.



Third seat row.

For the first time, the GLE is now available with an optional third seat row that includes two full-size seats. Access to the third row is easy, while the flexibility provided by an adjustable second seat row makes the footwell very adaptable.



Rear seats electrically adjustable.

The electrically adjustable second seat row brings a convenient level of flexibility: extend the load space at the simple touch of a button and position the rear seats as you require them. It all makes for a quick and easy way to create extra load capacity and comes with the optional third seat row.



Widescreen Cockpit.

Design that impresses, right from the start: the elegant Widescreen Cockpit. And the more you explore, the better it gets: choose between various display styles, follow the navigation guidance provided by MBUX, position the displays as you want them. All on two large 31.2 cm (12.3-inch) displays under a stylish glass cover.



Burmester® high-end 3D surround sound system.

An audio experience comparable with that of a top-end home music system. Loudspeakers within the roof liner compose a three-dimensional sound. You conduct the system as if it were your personal orchestra – with VIP settings for specific seats or stylistic requests such as “Live” or “Easy Listening”. Perfection in design and engineering: the extendable tweeters.

*Not available on the GLE 53. Available as optional equipment on all other variants.



Driving Assistance Plus Package.

The Driving Assistance Plus Package tangibly reduces the strain on the driver, particularly on long trips but also in confusing urban traffic. The new GLE is available with the very latest generation of this package, which can now provide support in even more driving situations: for example in a traffic jam or in advance of bends,

roundabouts or junctions. The new GLE can follow the vehicle in front even in stop-and-go traffic. This also relieves the driver of the bothersome task of restarting after each stop.

Various safety systems and features included in Mercedes-Benz vehicles are driver assistance aids only and the driver at all times remains solely responsible for maintaining proper control of the vehicle, ensuring safety and monitoring the driving environment and complying with all applicable road rules.

E-ACTIVE BODY CONTROL fully active suspension.

With the new E-ACTIVE BODY CONTROL fully active air suspension we are pooling our most innovative and intelligent suspension technologies to create a mesmerising driving experience.

In “Curve” mode, the vehicle can actively lean into a bend. This minimises the transverse force and tangibly increases comfort and dynamism. In “Comfort” mode, the ROAD SURFACE SCAN with stereo camera scans the road ahead of the vehicle. The suspension struts are then activated so as to substantially reduce the body movements when driving over bumps in the road.

Available as optional equipment on the GLE 450 4MATIC and GLE 400 d 4MATIC
Only in conjunction with AIRMATIC Package (DMT)

Technical data.

	Diesel engines		Petrol engine	
	GLE 300 d	GLE 400 d	GLE 450	GLE 53
Displacement (cc)	1950	2925	2999	2999
Rated output ¹ (kW [hp] at rpm)	180 [245] @ 4200	243 [330] @ 3600-4000	270 [367] @ 5500-6100	320 [435] @ 6100
Acceleration from 0 to 100 km/h (s)	7.2	5.7	5.7	5.3
Fuel consumption ⁴ (l/100 km)				
Urban	7.8	9.1	11.1	11.8
Extra-urban	6.4	6.8	8.0	8.0
Combined	6.9	7.7	9.1	9.4
Combined CO ₂ emissions ⁴ (g/km)	182	202	207	214

The best for the engine:
Mercedes-Benz genuine engine oils.

The declared fuel and energy consumption figures are determined by testing under standardised laboratory conditions to comply with ADR 81/02. Real world fuel consumption is influenced by many additional factors such as fuel quality, individual driving style, load, traffic, and vehicle condition. The declared fuel consumption figure should only be used for the purpose of comparison amongst vehicles. For more technical data, please visit www.mercedes-benz.com.au

Dimensions.

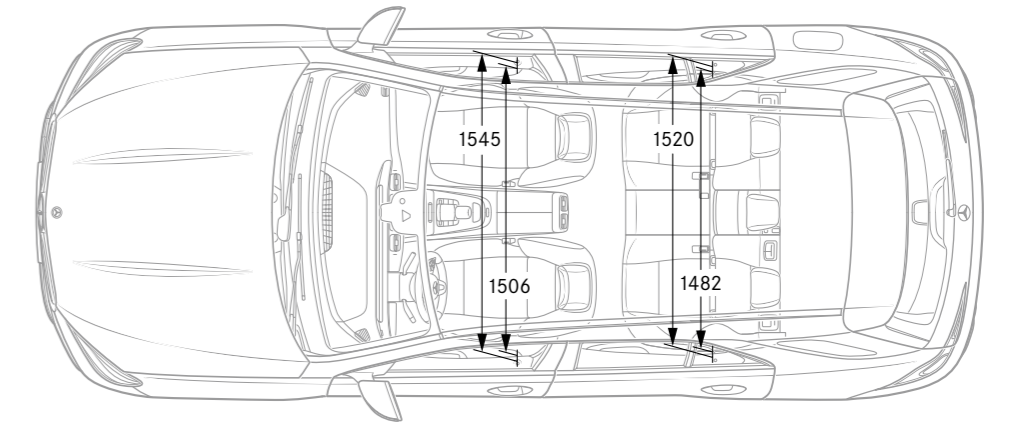
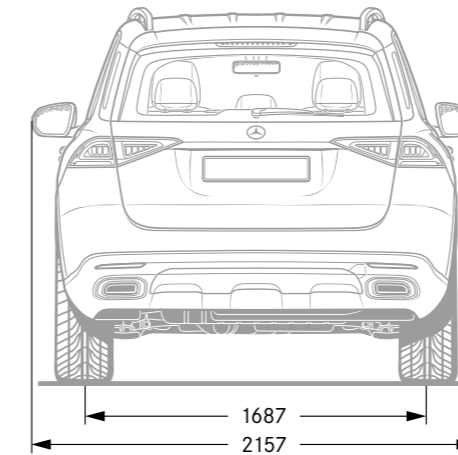
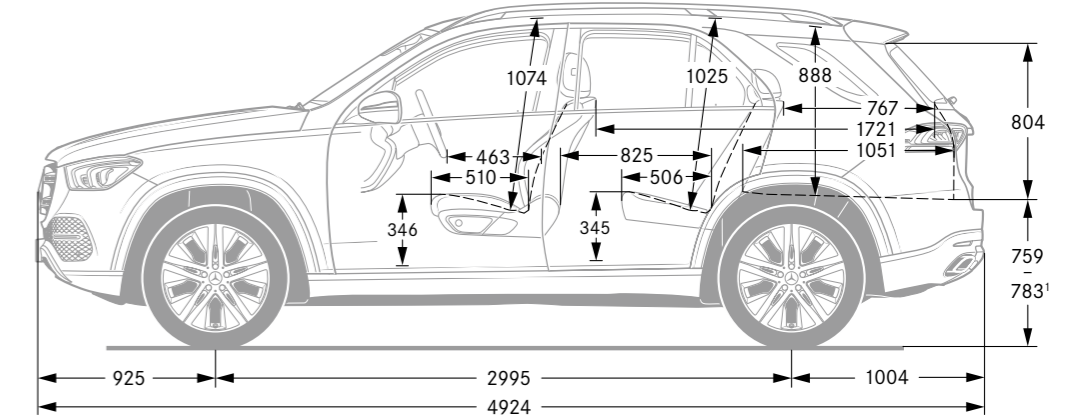
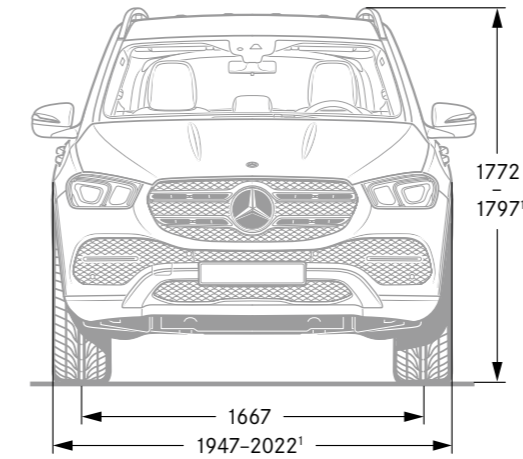

¹ At minimum to maximum height with steel suspension. All figures in millimetres. The illustrated dimensions are mean values. They are valid for vehicles in basic specification and in unladen condition.



SPORT — F O R — GOOD

Mercedes-Benz is one of the founding partners of the worldwide “Laureus Sport for Good Foundation”, which was established in 2000. It is the Mercedes-Benz brand’s most important social initiative. Laureus Sport for Good supports children and young people in need through social sports projects, opening up new perspectives and imparting important values such as team spirit, respect and determination. “Change the Game for Kids” is our mission statement which we wish to share with you. In buying a Mercedes-Benz you are supporting the “Laureus Sport for Good” movement.

About the information in this publication: Changes may have been made to the product since the editorial deadline on 13.07.2018. The manufacturer reserves the right to make changes to the design, form, colour and the delivery scope during the delivery period, provided these changes, while taking into account the interests of the seller, can be deemed reasonable for the buyer. Where the seller or the manufacturer uses symbols or

numbers to describe an order or the subject of an order, no rights may be derived solely from these.

The illustrations may also show accessories and optional equipment, which are not part of the standard delivery scope. Therefore, please ask your Mercedes-Benz sales representative about the provisions and effects applicable in other countries and about the latest definitive version. www.mercedes-benz.com.au