

# The A-Class Sedan



Mercedes-Benz



This Brochure is prepared by Mercedes-Benz Group AG and it predominantly reflects the capabilities and performance of vehicles sold in Europe. Some characteristics, capabilities, performance features and optional extras (e.g. towing systems) may not be available or may not apply in Australia or under Australian conditions. The information in this Brochure is therefore indicative, illustrative and provided only for guidance and should not be relied on. To obtain current and accurate information on a vehicle and any options applicable to Australia, contact your local authorised Mercedes-Benz retailer. The declared fuel and energy consumption figures are determined by testing under standardised laboratory conditions to comply with ADR 81/02. Real world fuel consumption is influenced by many additional factors such as fuel quality, individual driving style, load, traffic, and vehicle condition. The declared fuel consumption figure should only be used for the purpose of comparison amongst vehicles.

## The Sedan. Now also as an A-Class.

One of the most traditional automotive shapes has now become one of the most cutting-edge designs. The new A-Class Sedan interprets the 3-box design more sportily than ever.



More spacious feeling.





Knows the way home.  
And your habits.

MBUX, the new Mercedes-Benz User Experience, makes the new A-Class Sedan more intelligent than ever before. It learns more every day and, most of all, gets to know its driver better all the time. It can remember your favourite songs and the way to work. It then automatically selects the right radio station or shows you a faster way if your usual route is congested. All by itself and as a matter of course, if that is what you want.

## Energising comfort and exemplary safety.

Be it at rush hour, during a long drive at night or on an unfamiliar route, your new A-Class Sedan noticeably takes the strain off you, particularly in stressful situations. It's all down to a concept that makes every journey in a Mercedes-Benz a safer and exceptional experience: Mercedes-Benz Intelligent Drive. Because the time you spend behind the wheel is your time. Time for relaxation. Time to replenish your energy. So that, first and foremost, you reach your destination safely, but are also relaxed when you get there.





Each line a clear statement.

The sloping front end of the new A-Class Sedan gives it the streamlining to move against the flow. It features an upright radiator grille and a long, low bonnet line. Genuine highlights to left and right: the optional MULTIBEAM LED headlamps simply exude innovative power. As a consequence, the new A-Class Sedan appears to hug the road even more closely. And make our hearts beat faster.





The rear end of the A-Class Sedan.  
The beginning of a new design era.



The new and puristic styling of the A-Class finds elegant fulfilment in the Sedan: it features a distinctive rear end, in which two-piece tail lamps add to the impression of breadth. Not just great looking, but also great in terms of size, is the load compartment behind all this. And with the option of the HANDS-FREE ACCESS function with the KEYLESS-GO Comfort Package, it even comes with contactless opening.

The new A-Class Sedan.

With Mercedes 





## Safety and assistance.

Thanks to radar sensors and a 3D stereo camera, the new A-Class Sedan monitors its surroundings and is able to maintain the correct distance to the vehicle ahead at speeds of up to 210 km/h as well as brake automatically in an emergency situation.



## MULTIBEAM LED.

MULTIBEAM LED headlamps adapt to the visibility conditions and other road users within a split second. The partial main beam, for instance, masks out identified road users, so ensuring that the road surface is always ideally illuminated without dazzling oncoming vehicles.

Various safety systems and features included in Mercedes-Benz vehicles are driver assistance aids only and the driver at all times remains solely responsible for maintaining proper control of the vehicle, ensuring safety and monitoring the driving environment and complying with all applicable road rules.



## Mercedes-Benz User Experience.

MBUX (Mercedes-Benz User Experience) doesn't do the driving for you, but it makes the experience as enjoyable as possible. Artificial intelligence means that the system is capable of learning so that, over time, it gradually adapts itself better to the driver. You can converse with the LINGUATRONIC intelligent voice control system almost as naturally as you would with a good friend.

## Smartphone Integration.

In the new A-Class Sedan you can charge your smartphone by placing it on the centre console. And the best thing: thanks to near-field communication (NFC), your smartphone immediately connects to the A-Class Sedan without a lot of intermediate steps or having to enter a code.

Sending text messages or scrolling through contacts is also no problem at all. In the new A-Class Sedan you can use your smartphone without having to pick it up. Use USB or NFC to connect to the vehicle. Then conveniently control almost all apps and functions via the multimedia system display using the Touch Control buttons on the steering wheel.

Wireless charging feature only compatible with devices that support the Qi standard. Check the compatibility of your device and vehicle in Australia at [www.mercedes-benz-mobile.com](http://www.mercedes-benz-mobile.com) for your device manufacturer.







## “Wrap-around” design.

The interior of the new A-Class Sedan literally hugs the occupants. Smooth transitions between instrument panel, centre console and door trims create the pleasant wrap-around design. This is just as unique in this category as the selection of trim elements and ambient lighting to stage every detail perfectly.

## Widescreen display.

Here one glance says more than a thousand words. The interior of the new A-Class Sedan has a strikingly unusual appearance, giving you a completely new view of things. Not just on one, but on two high-resolution displays, 17.78 centimetres (7 inches) in size as standard. Or extra-large, at 26 centimetres (10.25 inches) as an option. In either case, the screens seem to be floating within the interior. They are also super-easy to operate using the Touch Control buttons on the steering wheel, the optional touchpad or the touchscreen. The latter represents another “world first” that is definitely worth another look.



## Head-up display.

You will automatically have your eyes on the road with the head-up display in the new A-Class Sedan, because it directly projects all relevant information, such as speed, speed limits or navigation information into your field of vision. Virtually and in full colour. The content of the display can be adapted and saved as part of the memory function.



## Seating comfort and spaciousness.

If you take a look around in the new A-Class Sedan, you may be surprised to find just how spacious it is. In the rear, in particular, even tall occupants will enjoy the ride. The new A-Class features sports seats with adjustable head restraints. Multicontour seats are available in conjunction with luxury seats. Seat climate control and different upholstery may be selected as options. It all adds up to top-class travelling comfort.



## DYNAMIC SELECT.

Just drive as you want to. At the press of a button DYNAMIC SELECT offers different drive programs with setting options for the engine, transmission, chassis and steering, for instance. With the “Sport” mode you drive decidedly dynamically, with the standard “Comfort” program very harmoniously. “ECO”, on the other hand, places the emphasis on maximum efficiency, saving both fuel and money.

The “ECO” drive program gives you particularly comprehensive support when you want to avoid CO<sub>2</sub> and pollutants. The seat heating and air conditioning work with reduced output in this setting and thus also save valuable energy. With “Individual”, you choose all the respective parameters yourself. This means that you can select a sporty setting for the drive system and at the same time have a comfortable setting for the chassis.

Illustration shows the A-Class Hatchback W177.

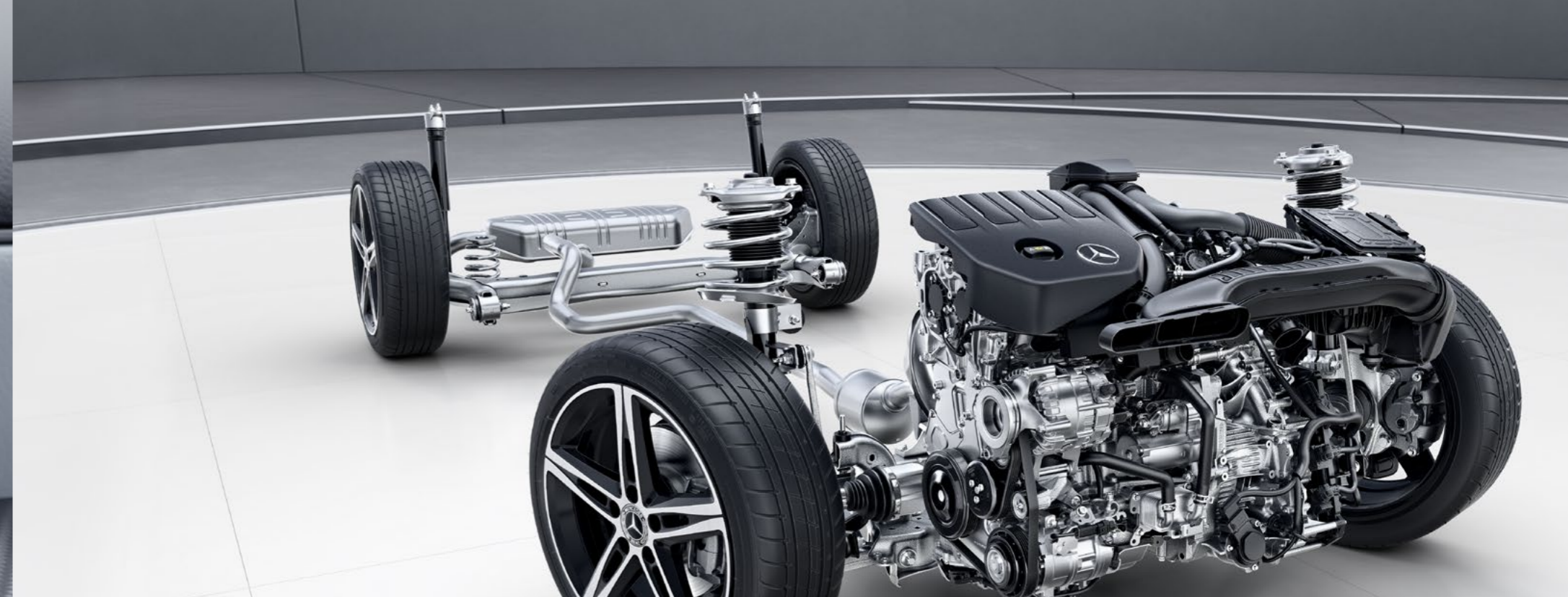

## Comfort suspension.

Enjoy a high level of comfort on long motorway stretches while tackling tight curves with sporty flair. The balanced comfort suspension provides an impressive mix of responsive

suspension reserves with excellent driving stability. This makes your driving safe while at the same time providing a great deal of driving pleasure.

## Technical data.

	Petrol engine	
	A 180	A 200
Displacement (cc)	1332	1332
Rated output <sup>1</sup> (kW [hp] at rpm)	100 [136] @ 5500	120 [163] @ 5500
Acceleration from 0 to 100 km/h (s)	8.9	8.1
Top speed (km/h)	216	230
Fuel consumption <sup>4</sup> (l/100 km)		
Urban	7.2	7.2
Extra-urban	4.7	4.7
Combined	5.7	5.7
Combined CO <sub>2</sub> emissions <sup>4</sup> (g/km)	130	130

The declared fuel and energy consumption figures are determined by testing under standardised laboratory conditions to comply with ADR 81/02. Real world fuel consumption is influenced by many additional factors such as fuel quality, individual driving style, load, traffic, and vehicle condition. The declared fuel consumption figure should only be used for the purpose of comparison amongst vehicles. For more technical data, please visit [www.mercedes-benz.com.au](http://www.mercedes-benz.com.au)

## Dimensions.

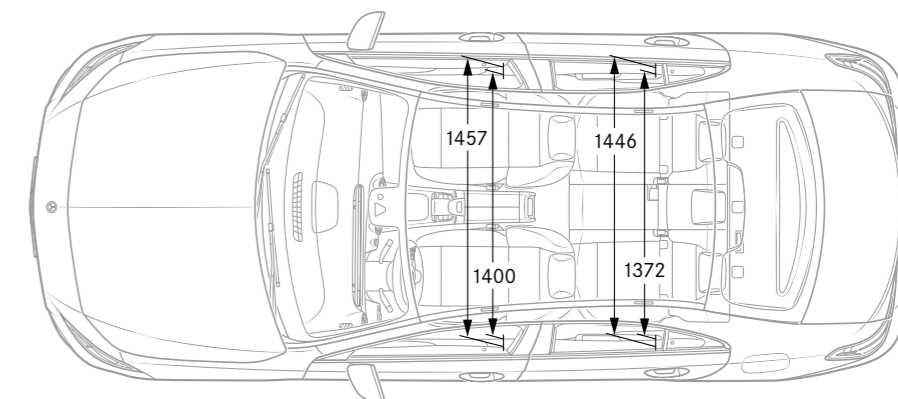
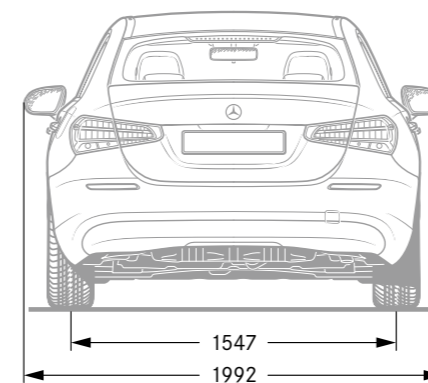
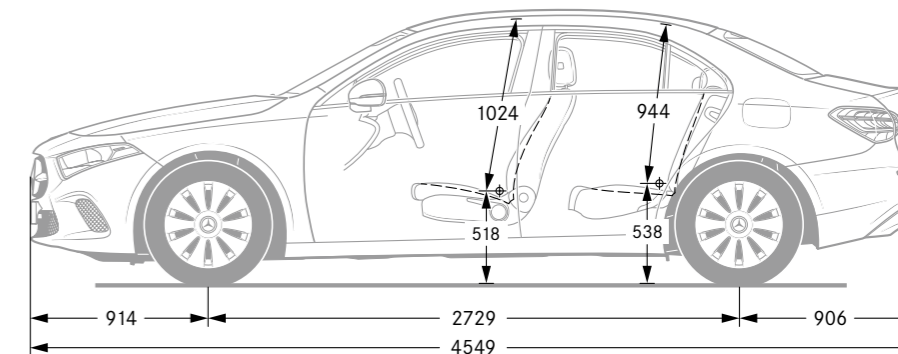
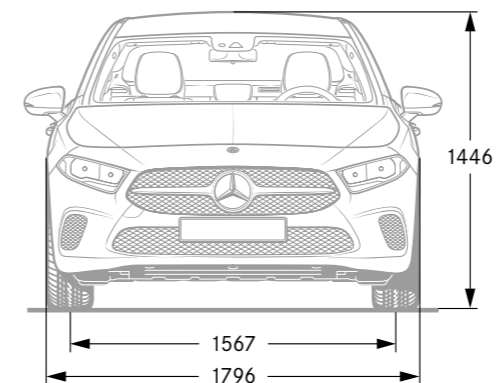

All figures in millimetres. The illustrated dimensions are mean values. They are valid for vehicles in basic specification and in unladen condition.



# SPORT — F O R — GOOD

Mercedes-Benz is one of the founding partners of the worldwide “Laureus Sport for Good Foundation”, which was established in 2000. It is the Mercedes-Benz brand’s most important social initiative. Laureus Sport for Good supports children and young people in need through social sports projects, opening up new perspectives and imparting important values such as team spirit, respect and determination. “Change the Game for Kids” is our mission statement which we wish to share with you. In buying a Mercedes-Benz you are supporting the “Laureus Sport for Good” movement.

About the information in this publication: Changes may have been made to the product since the editorial deadline on 28.05.2019. The manufacturer reserves the right to make changes to the design, form, colour and the delivery scope during the delivery period, provided these changes, while taking into account the interests of the seller, can be deemed reasonable for the buyer. Where the seller or the manufacturer uses symbols or numbers to describe an order or the

subject of an order, no rights may be derived solely from these. The illustrations may also show accessories and optional equipment, which are not part of the standard delivery scope. Therefore, please ask your Mercedes-Benz sales representative about the provisions and effects applicable in other countries and about the latest definitive version.

[www.mercedes-benz.com.au](http://www.mercedes-benz.com.au)