

Introducing JAGUAR:

The SS Jaguar was unveiled in London's Mayfair Hotel in October, 1935. Its introduction was followed shortly by that of the SS-100. Both of these sleek, fast, gracefully-appointed automobiles created a sensation in the automotive and fashion worlds.

Jaguar cars have been creating sensations ever since.

In 1948, the famous Jaguar XK-120 Sports Two-Seater was introduced at the International Motor Show, in London. Another major sensation was recorded throughout the world by this amazing car, which was destined to set a world's speed mark of 172.412 miles per hour, in 1953.

In 1953, Jaguars swept the Le Mans, France, 24-hour Grand Prix d'Endurance, finishing first, second, fourth and ninth. In 1956, they finished first, fourth and sixth. In 1957, they finished first, second, fourth and sixth against an international field of the world's fastest sports cars. Jaguars have won this most grueling of all motor races five times in seven starts.

Out of a wealth of experience gained on the race track have come a notable succession of Jaguar cars: the Luxury Series—high-performance sedans often called, "The finest cars of their class in the world"; the XK Series—universally accepted as setting the standard by which all sports cars are judged; and the Sports Sedans—versatile and lithe, combining sports car performance with family-car comfort.

The history of Jaguar has been one of classic styling, high-performance and endurance. It is doubtful whether any other automobile ever compressed so many performance records and so much public acclaim into so few years.



JAGUAR XK-E COUPE

By victory after victory on the racetracks of the world, Jaguar has earned for itself a position in the very front rank of modern sports cars.

Five times winners at Le Mans, three times victors at Rheims, several times winners of the R. A. C. Tourist Trophy and victorious in innumerable other International and National events, the racetrack breeding of Jaguar is evident from the moment the wheel is handled.

All the accumulated wealth of knowledge and experience gained in the hard school of racing have been built into the new XK-E Jaguar models, one of the fastest production sports cars ever offered for public sale.

XK-E models are equipped with 3.8 litre twin overhead camshaft XK engines, with three carburetors, developing 265 b.h.p. at 5,500 r.p.m., with straight port cylinder heads of high tensile aluminum alloy and with hemispherical combustion chambers.

These engines provide a new high level of performance, yet, notwithstanding the high speed potential of XK-E, the Jaguar characteristics of smoothness, silence, tractability and road adhesion are such that complete and effortless mastery is in the hands of the driver at all times and at all speeds.

The construction of the XK-E is unique, since it comprises a stressed shell, all-steel body of patented monocoque construction, which was developed and proven in the famous "D" Type Jaguar competition car in many of the world's most grueling races.

This form of construction has made it possible to reduce weight drastically, without compromising strength or rigidity. The XK-E is, therefore, approximately 600 pounds lighter than its predecessor, which makes this car capable of truly outstanding performance.

The two-door, two-seater bodies possess extremely low drag characteristics, resulting from *(continued)*

XK-E COUPE

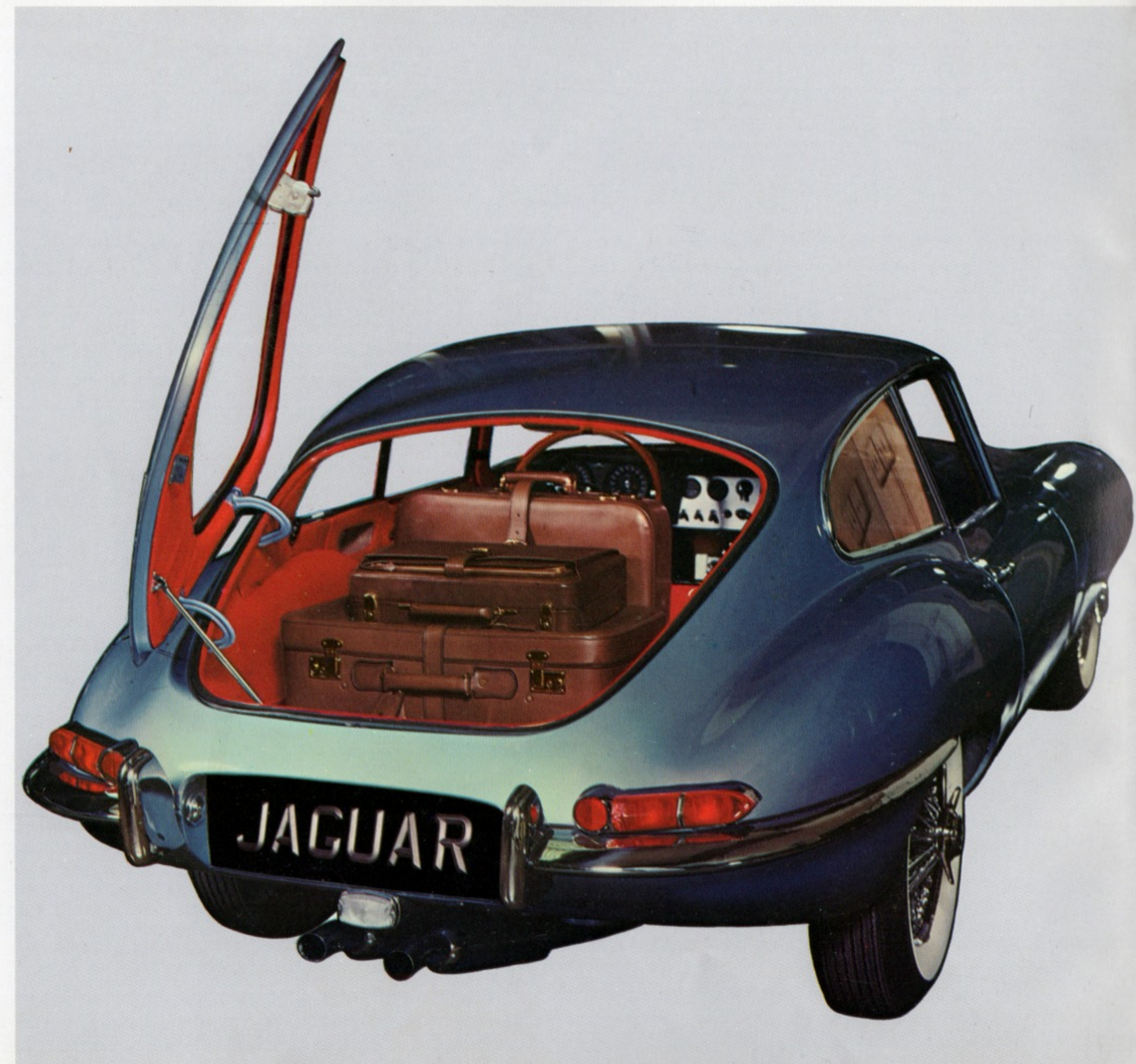

Large counterbalanced door at rear, with release catch located in car, incorporates window and gives unobstructed access to luggage compartment, spare wheel and tools; hinged luggage container behind seats drops down to increase floor space if desired.

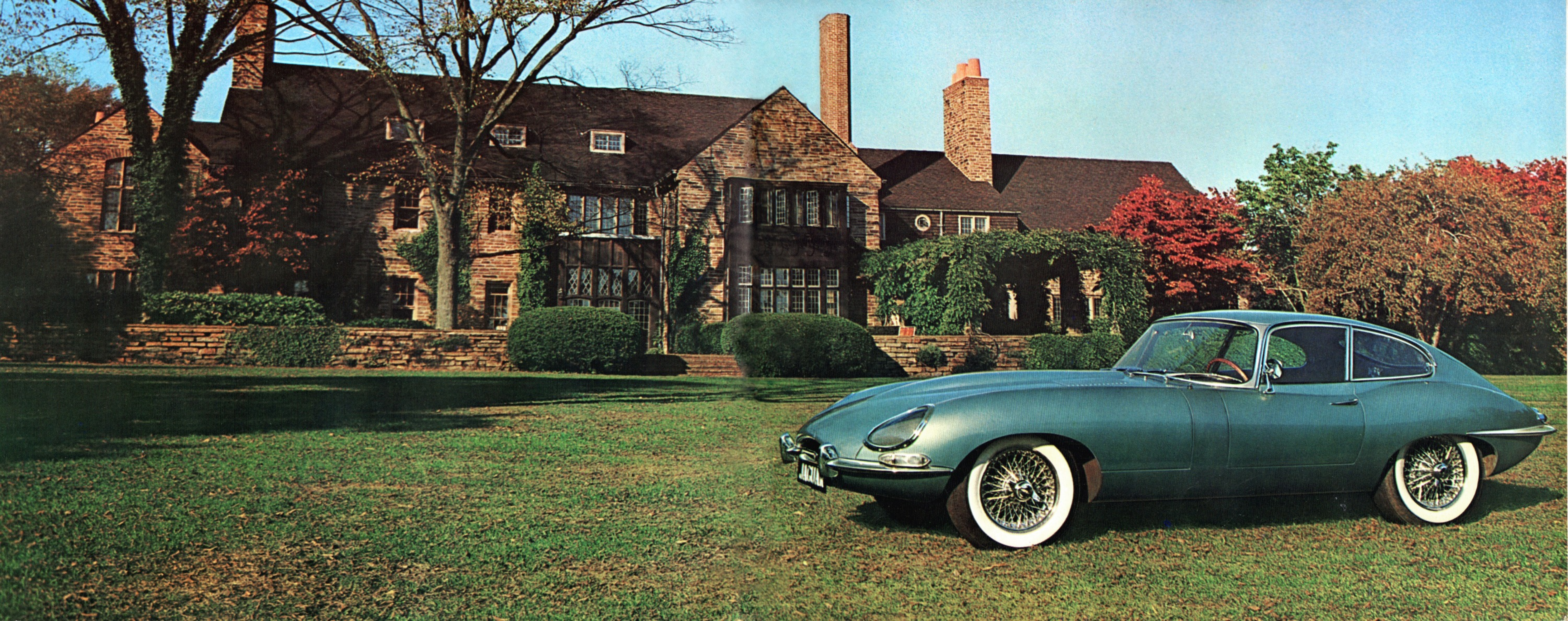

JAGUAR XK-E ROADSTER

(continued from preceding page) extensive wind-tunnel tests.

To compensate for the very high potential of which the XK-E models are capable, a suspension system has been designed to give brilliant roadholding characteristics under all driving conditions.

Independent front suspension incorporates transverse wishbones and torsion bars controlled by telescopic hydraulic dampers. Anti-roll bars are fitted to lower wishbones. Fully independent rear suspension incorporates, on each side, a lower transverse tubular link pivoted at the wheel carrier and subframe adjacent to the differential case and, above this, a jointed halfshaft.

Longitudinal location is provided by the rubber mountings locating the assembly in the body structure and by a radius arm between the lower link and a mounting point on the body structure. Twin coil springs, each enclosing a telescopic hydraulic damper,

provide the suspension medium. The whole assembly, together with the differential unit, is carried in an easily detachable subframe which is located in the body structure by rubber mountings.

An entirely new braking system has been developed for the XK-E models. It comprises Dunlop bridge-type four-wheel disc brakes, featuring quick-change pads. The front discs are fitted to the wheel hubs, while the rear discs are inboard, to reduce unsprung weight. The brake pedal operates twin master cylinders through a compensating device, which divides the system into two entirely independent hydraulic systems to the front and rear brakes.

Jaguar is proud to introduce the XK-E Two-Seater Sports Cars to that segment of the motoring public that places strong emphasis upon very high performance, luxury and safety; indeed the highest performance and prestige ever offered at such modest cost.

XK-E ROADSTER

Twin bucket seats, adjustable for reach, upholstered in finest leather over foam rubber; adjustable three-spoke steering wheel of polished lightweight alloy, with wood rim; wind-up windows; console for radio and twin speakers.

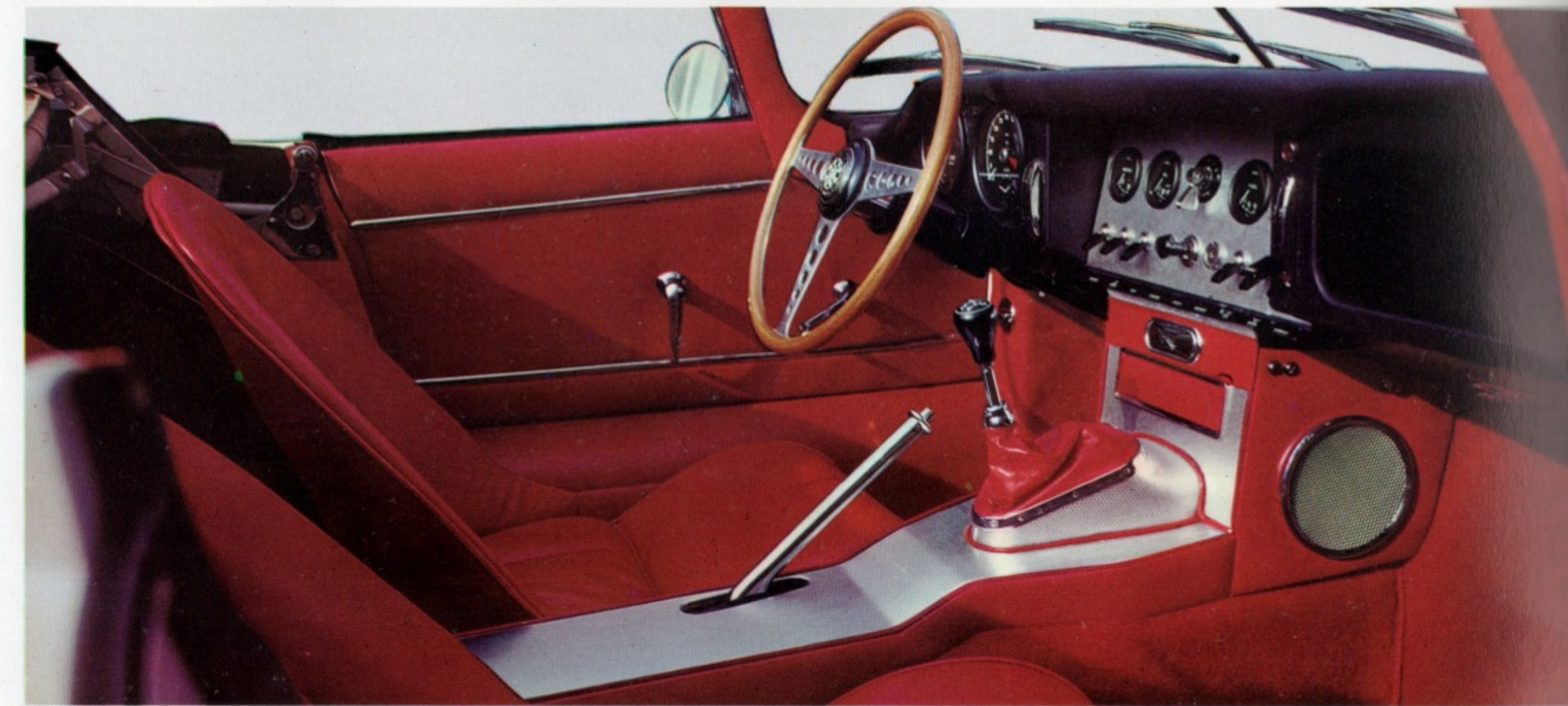

Interchangeable hard or soft convertible top. Three section instrument panel, with r.p.m. counter, 160 m.p.h. speedometer; oil pressure, water temperature and fuel gauges; fuel and brake fluid warning lights.





JAGUAR 3.8 SEDAN

From the moment of their introduction the 3.8 litre Jaguar Sedans scored such instantaneous successes and created such world wide demand that a doubling of the Company's output became necessary.

It is evident now that the 3.8 Sedan is one of the most versatile automobiles ever built. It sums up luxury touring in a high-performance car that defies comparison, bringing together without compromise the responsiveness and handling of the true sports car, with the convenience of a four-door, five passenger family sedan.

In the 3.8 Sedan, the renowned Jaguar XK engine, 4-wheel disc brakes, dramatic acceleration and speeds in excess of 120 miles-per-hour combine with enduring performance, safety and Jaguar's well-known prestige standards in design and fittings. These are reason in abundance why a noted automotive writer said of the 3.8 Sedan, "It has no exact American counterpart!"

An examination of this catalogue will reveal such advantages as greatly enhanced all-around vision, super efficient disc brakes and clear-view instruments, with conveniently grouped hand controls within instant reach. Interior heating has received special attention and, with it, adequate ventilation.

Even such seemingly trivial details as the number, size and location of ashtrays, the interior illumination of the glove compartment and the provision of a luminous cigarette-lighter socket have been worked out with as much care as the development and fitment of the 4-wheel disc brakes.

The full specifications to be found in this catalogue will repay the closest study, for they reveal that in technical excellence and in appointments and fittings, the 3.8 Jaguar represents the most advanced and lavishly equipped Sedan of modern dimensions ever offered to discriminating motor car buyers in North America.

Walnut flush-fitting occasional tables, soft leather upholstery over foam rubber, armrests.



Polished walnut instrument panel; housing for radio, speaker, heater controls and ashtray.

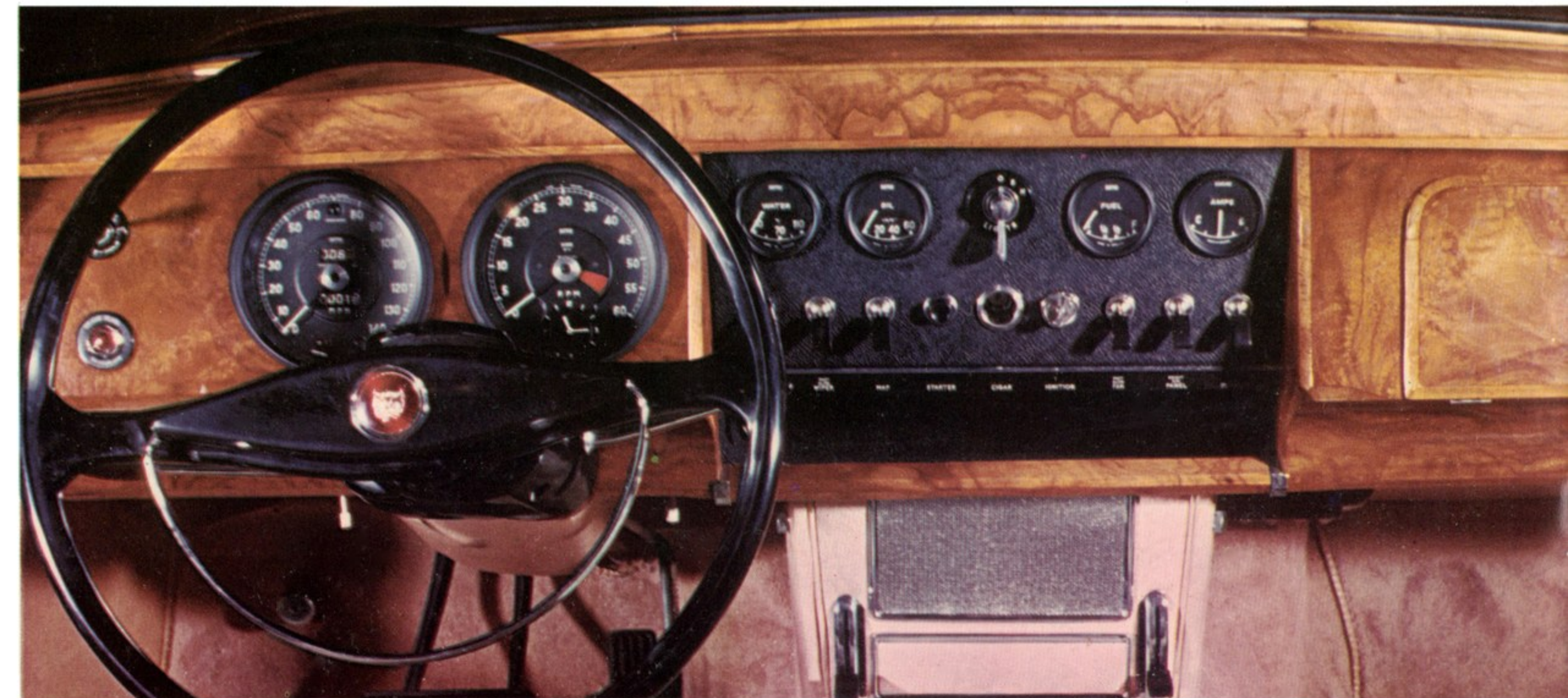

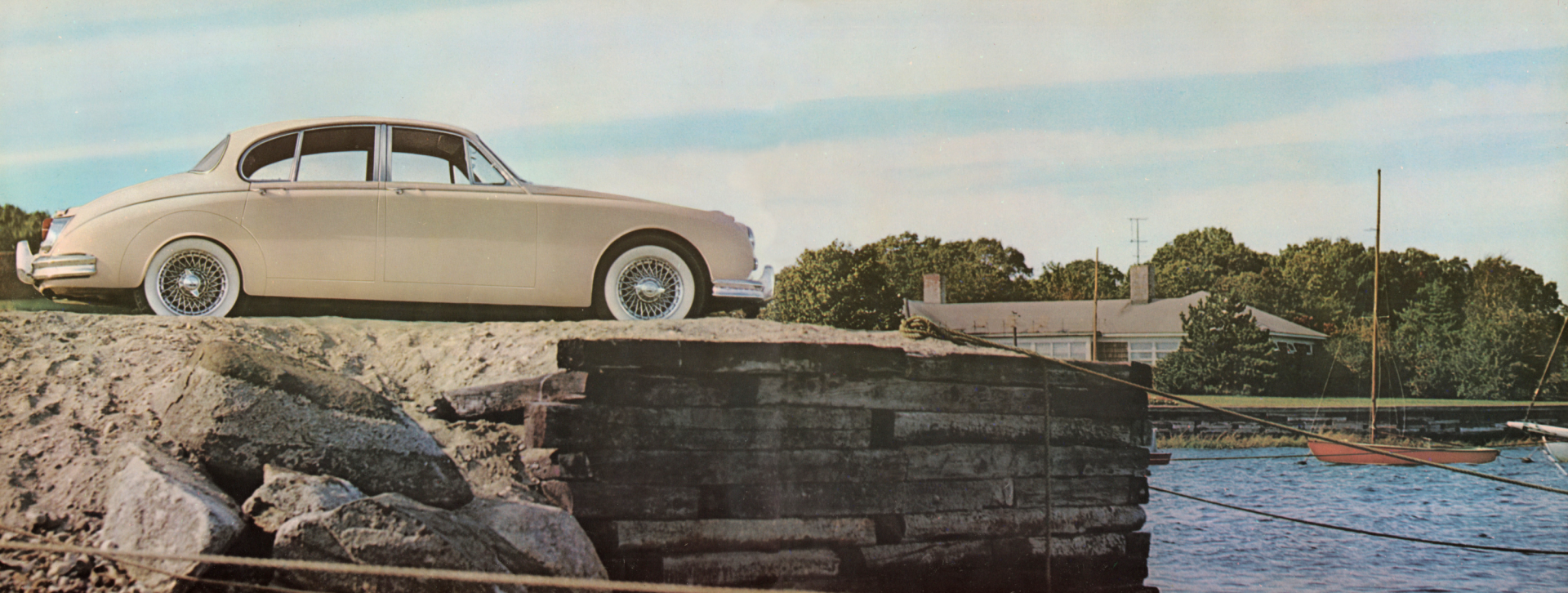

JAGUAR MARK X SEDAN

In its line of luxury sedans, Jaguar has created an international standard for supreme motor cars, in which high performance, classic design and faultless craftsmanship have been combined to produce "the finest cars of their class in the world."

The Jaguar Mark X, although entirely new in construction, design and appearance, stems from a long and illustrious line of outstanding models, beginning with the Mark VII which was introduced in 1950. All have achieved renown in their own right and have formed important links in a chain of development culminating in the creation of the finest car yet to be produced in the Jaguar big sedan tradition—the Mark X.

This elegant model is of monocoque construction. It possesses many of the characteristics of the recently-introduced, widely-acclaimed XK-E Sports cars and it is powered by the world-famous Jaguar XK "S" Type 3.8 litre twin overhead camshaft engine, with three carburetors. Producing 265 horsepower, this engine, save for minor details, is identical with that fitted to the XK-E models and it endows the Mark X with

a degree of performance far superior to that of the Mark IX, which it supplants.

Independent suspension front and rear, and disc brakes on all four wheels, enable full advantage to be taken of this performance, with safety and comfort. Accurate, finger-light, power-assisted steering ensures completely effortless control. Power windows and air conditioning if desired, and a high efficiency dual-control heating system are other amenities designed for enhanced passenger comfort.

Never before has a car been so esthetically satisfying. Instrument panel, garnish rails, window surroundings and rear interior appointments are carried out in figured walnut carefully matched. Only selected skins from the finest hides are used for the sumptuous leather upholstery. Deep pile carpeting is underfoot. Reclining seats and folding tables are standard equipment.

Built to an ideal, the Jaguar Mark X, with its coachwork finish, luxurious interior furnishings and advanced technical specifications, takes its place as a distinguished addition to a line of superb motor cars.

The genuine leather hides chosen for the Mark X are of impeccable quality, and are upholstered over deep foam cushions. Passengers will delight in the spaciousness attained in the rear compartment, even when the front seats are in their extreme rearward position. Polished walnut vanity tables are fitted into the rear of the front seats. When opened, these tables reveal large rectangular mirrors placed at the correct angle for use. As you would expect, interior craftsmanship is flawless. Each appointment, each detail is executed with incomparable skill. Unnecessary adornments are avoided, for superfluous touches would only detract from the theme of the Jaguar Mark X... good taste and correctness.





XK-E COUPE

SEATING DIAGRAMS & GENERAL DIMENSIONS

SPECIFICATIONS

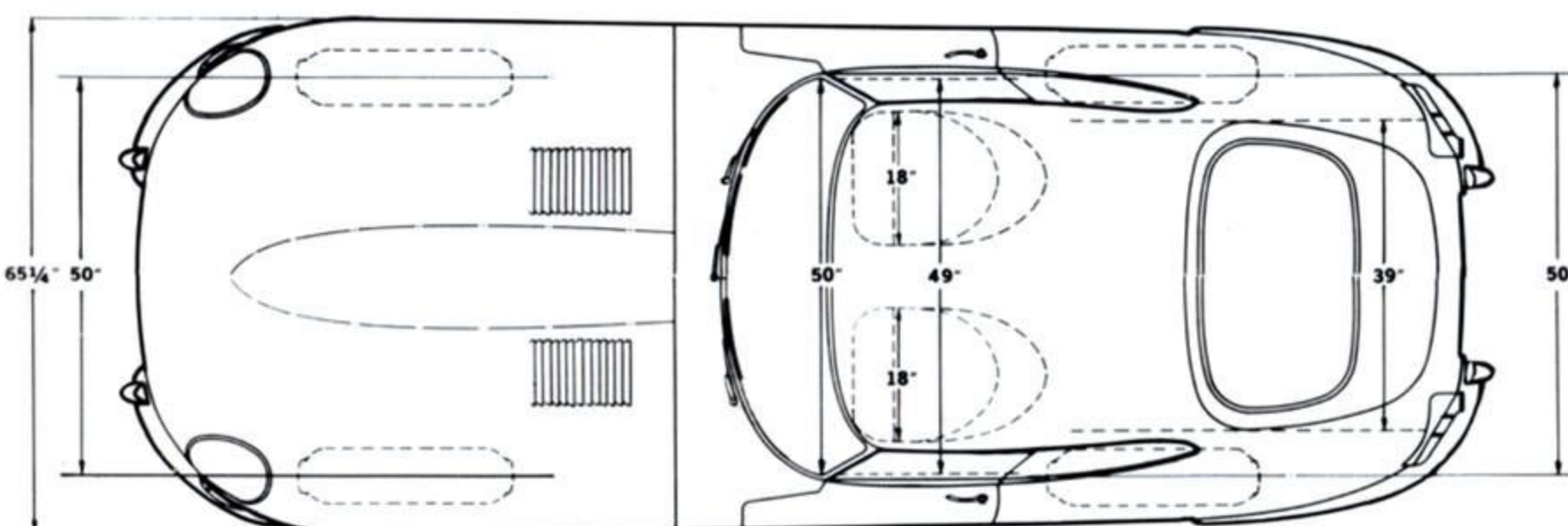
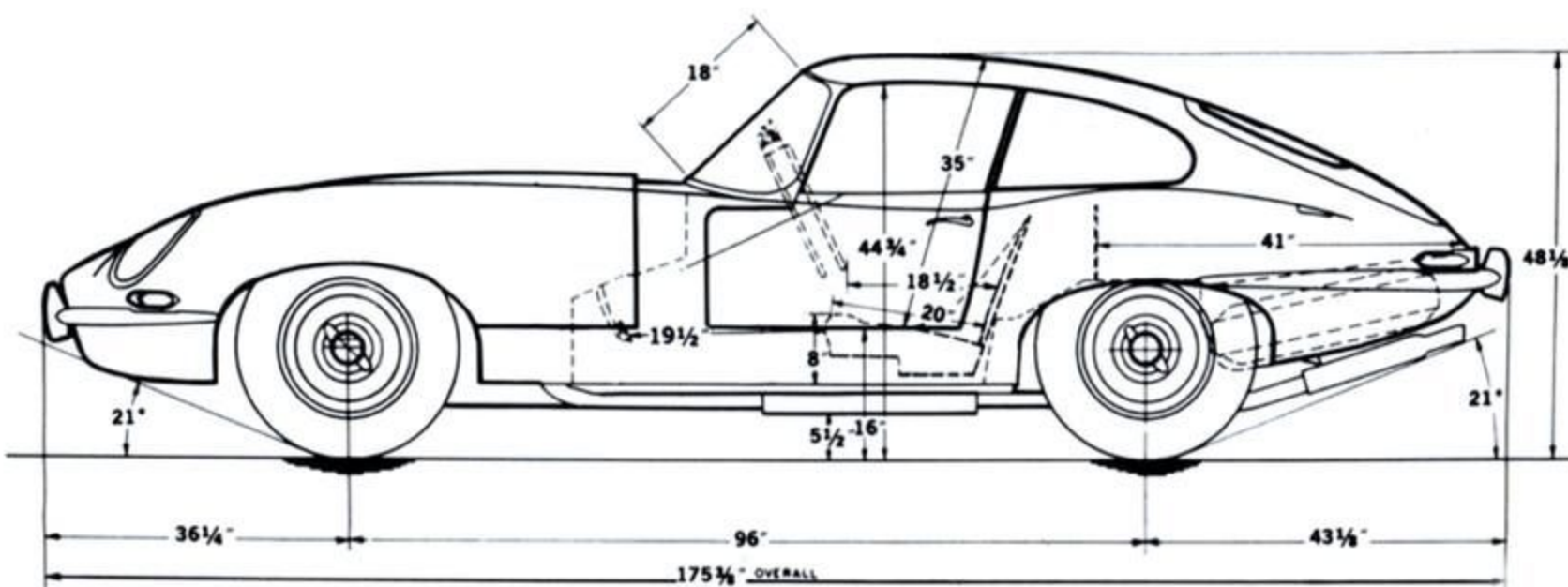

BODY AND APPOINTMENTS: Two-door two-seater body of extremely low drag characteristics resulting from intensive wind tunnel testing. Counterbalanced forward opening front section provides excellent accessibility to all mechanical components. Large door at rear, with release catch located in car, incorporates rear window and gives unobstructed access to luggage compartment, spare wheel and tools. Lipped-shelf provided immediately behind seats for small parcels, etc., and whole of body behind seats available for luggage. Hinged luggage-retainer at front of compartment drops down to increase floor space if required. Large window area together with wrap-around windshield and thin screen pillars provide superb all round visibility. Door windows completely concealed within doors when fully lowered. Hinged rear-quarter windows. Wrap-around bumpers with overrides at front and rear. Chrome finishers on rain gutter and windshield frame. Twin bucket seats, adjustable for reach, upholstered in finest quality Vaumol leather over Dunlopillo foam rubber cushions. Three section instrument panel together with windshield rail mat-grained finish to eliminate reflections. Comprehensive instrumentation with 5-in. revolution counter, incorporating an electric clock, and 5-in. 160 m.p.h. speedometer, incorporating total and trip distance recorder, positioned in front of driver. Central panel contains separate instruments for electrically operated oil pressure, water temperature, fuel gauge, with low-level warning light, and ammeter, together with a row of labelled tumbler switches controlling ancillary equipment. Separate housing beneath panel contains a radio and twin speakers (optional extra) together with an ashtray. When no radio is fitted, the speaker grilles are retained and the radio control panel aperture is blanked off with an escutcheon. Panel in front of passenger contains an open-fronted glove compartment and grab handle. Three-spoke polished alloy lightweight steering wheel with wood rim and central horn push. Sun visors for driver and passenger. Wide-angle vertically-adjustable rear-view mirror incorporating anti-dazzle secondary mirror position. Deep pile carpets over thick underlay.

BODY CONSTRUCTION: Stressed shell all steel body of unique patented monocoque construction. Front subframe of square section steel tubing carries engine unit, suspension and forward hinged front section.

BRAKES: Dunlop bridge-type 4-wheel disc brakes, featuring quick change pads. Front brakes fitted on wheel hubs, rear brakes fitted inboard. Bellows-type brake servo operating directly onto brake pedal. Pedal operates twin master cylinders through a compensator device which divides the system into two entirely independent hydraulic systems to front and rear brakes. Centrally positioned self adjusting handbrake operates on rear wheels only. Brake fluid level warning light operates on both systems.

DIMENSIONS (Principal): Wheelbase, 8 ft. 0 in.; track, front and rear, 4 ft. 2 in.; over-all length, 14 ft. 7 1/16 in.; over-all width, 5 ft. 5 1/4 in.; over-all height, 4 ft. 0 in.; ground clearance (laden), 5 1/2 in.; dry weight, 2,520 lbs. approx.

ELECTRICAL EQUIPMENT: Lucas 12-volt system. Large capacity battery giving 57 amp./hour at 10-hour rate with current voltage control. Ventilated dynamo. Eight fuse control box, fully labelled, located behind hinged central instrument panel for ease of access. Side lamps. Headlamps with hand-operated dimmer-switch on instrument panel. Separate lever actuating headlamp flashing. Separate stop, tail, direction and reflector units mounted in a single assembly. Rear number plate lamps. Self-cancelling, flashing direction indicators and warning light on panel. Instruments and labelled switches illuminated by internal floodlighting controlled by a two-position dimmer switch. Map reading light. Interior light. Twin-blended note horns. Triple-blade, two-speed, self-parking, windshield wiper unit. Electrically operated windshield washers. Cigarette lighter with luminous socket. Starter motor. Vacuum and centrifugal automatic ignition control. Oil coil ignition. Wiring harness in quickly detachable front body section connected to main circuits through an eight pin connector mounted on left front nose section of body.

ENGINE: Six cylinder twin overhead camshaft 3.8-litre XK Jaguar "S" type engine. 87 mm. bore by 106 mm. stroke (3.425 in. x 4.1732 in.). Cubic capacity 3,781 c.c. (230.6 cu. in.). Compression ratio 9:1. Power output (9:1): 265 b.h.p. at 5,500 r.p.m.; torque: 260 ft. lbs. at 4,000 r.p.m. Three S.U. carburetors, type H.D.8 with manual choke control. Forced lubrication by submerged pump system incorporating a full flow filter. Chrome iron cylinder block fitted with dry type cylinder liners. Special "straight port" cylinder head of high tensile aluminum alloy featuring hemispherical combustion chambers and twin overhead camshafts operating large valves of 70° included angle. Aluminum alloy pistons. Steel connecting rods fitted with lead indium big end bearings, 2 3/4 in. diameter counterweighted crankshaft carried on seven large lead indium bearings. Pressurized cooling system with thermostatically controlled electrically driven fan.

FUEL SUPPLY: 16 3/4 gallon tank capacity. Lucas electric pump. Gas filter incorporated into fuel line and located in engine compartment.

HEATING AND DEMISTING: High-output fresh air heating and multi-point windshield demisting system incorporating a two-speed fan controlled by switch on panel. Temperature and volume of air controls on panel. Ducts direct air to each side of compartment.

JACKING: Centrally located jacking posts enable the front and rear wheels on either side of the car to be raised simultaneously by means of the jack provided.

SPARE WHEELS AND TOOLS: The spare wheel is carried beneath the trunk floor in a separate compartment and is readily accessible. Tool kit housed in the spare wheel compartment.

SUSPENSION: Independent front suspension incorporating transverse wishbones with torsion bars controlled by telescopic hydraulic dampers. Anti-roll bar fitted to lower wishbones. Fully independent rear suspension incorporating, on each side, a lower transverse tubular link pivoted at the wheel carrier and subframe adjacent to the differential case and, above this, a halfshaft universally jointed at each end. These serve to locate wheel in a transverse plane. Longitudinal location is provided by the rubber mountings locating the sub-assembly in the body structure and by a radius arm between the lower link and a mounting point on the body structure. Twin coil springs, each enclosing a telescopic hydraulic damper provide the suspension medium. The whole assembly together with the differential unit is carried in an easily detachable subframe which is located in the body structure by rubber mountings.

STEERING: Rack and Pinion. 16 in. steering wheel with separate adjustments for height and reach, 2 3/4 turns from lock to lock. Turning circle, 37 ft.

TRANSMISSION: Manually-operated four speed, single helical synchromesh gearbox. Centrally positioned gear-shift lever. Synchromesh on top, third and second gear ratios. Borg & Beck 10 in. single dry-plate clutch with hydraulic operation. Hardy-Spicer Needle-Bearing propeller shaft. Hypoid rear axle fitted with limited-slip differential. Ratios 3.31:1. Optional axle ratios are available.

WHEELS AND TIRES: Wire-spoke wheels with center-lock hubs fitted with Dunlop 6.40 x 15 type RS.5 tires and tubes. Optional tire and wheel equipment available for racing: 6.00 x 15 front, 6.50 x 15 rear on special wheels.

XK-E ROADSTER

SEATING DIAGRAMS & GENERAL DIMENSIONS

SPECIFICATIONS

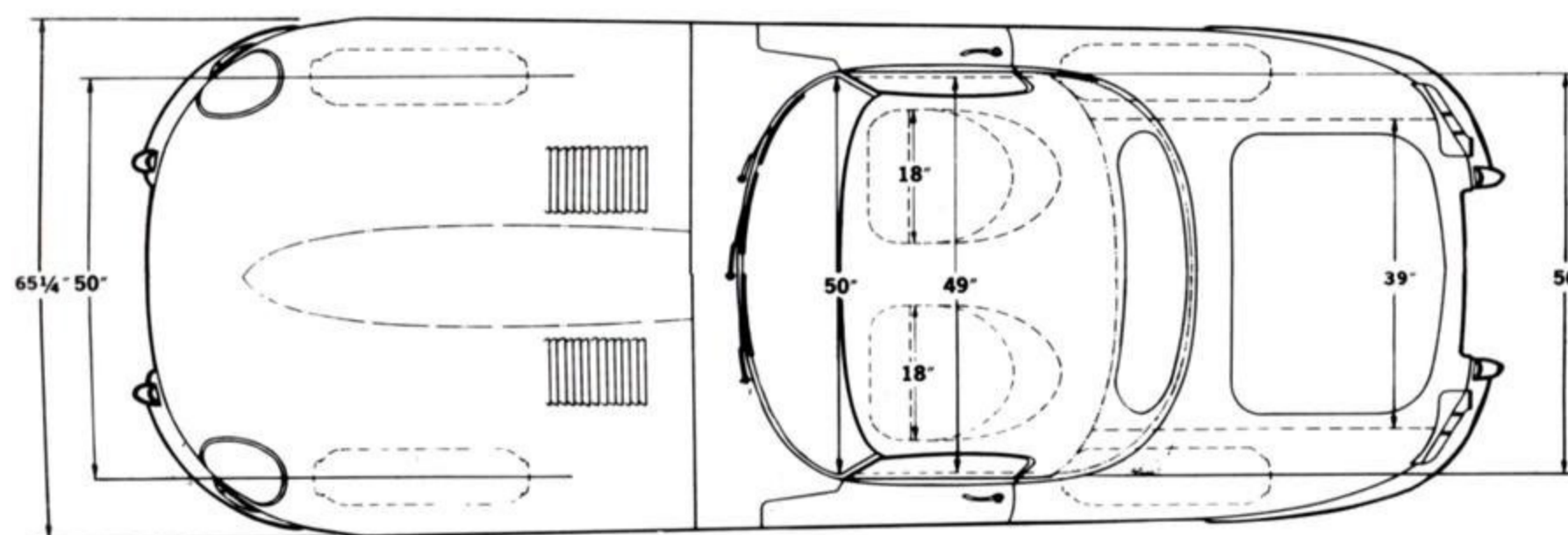
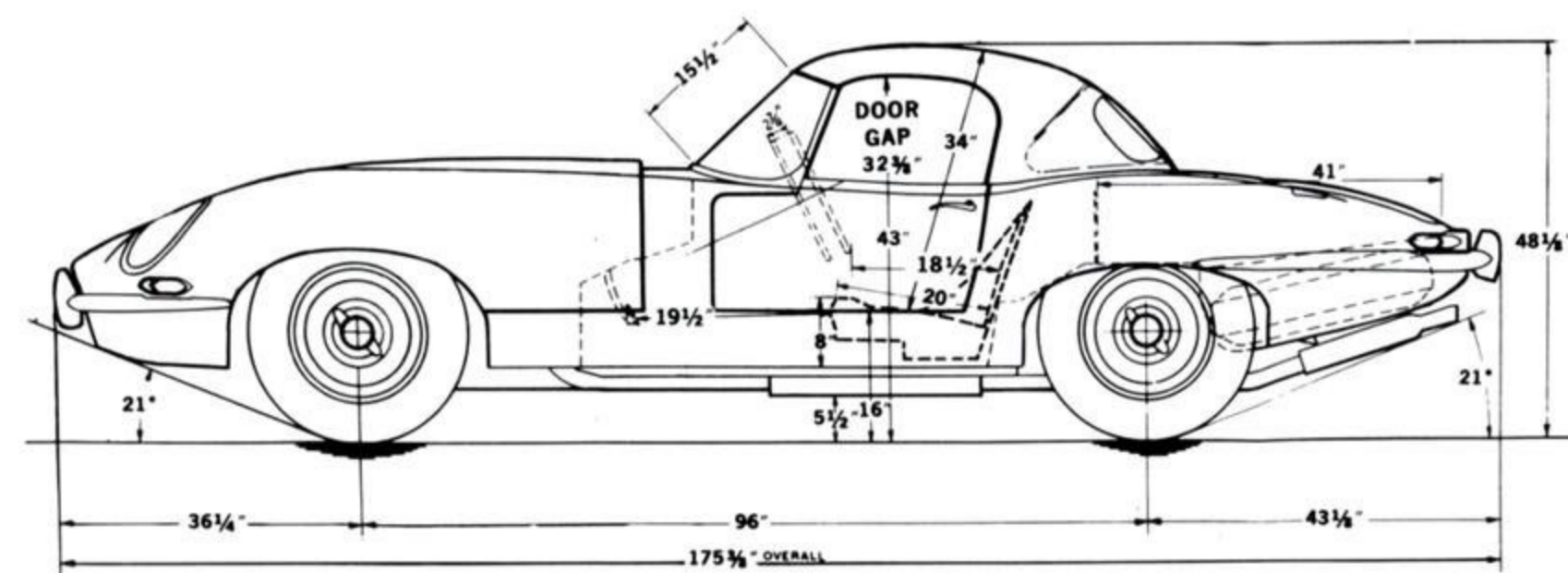

BODY AND APPOINTMENTS: Two-door two-seater body of extremely low drag characteristics resulting from intensive wind tunnel testing. The folding top, incorporating a large rear window, is of finest quality mohair, mounted on a special frame to permit single-handed erection or stowing. Fibreglass detachable hardtop available as an optional extra. Hardtop can be fitted without removing stowed top. Counterbalanced, forward-opening front section provides excellent accessibility to all mechanical components. Wrap-around windshield and thin pillars provide superb forward visibility. Door windows completely concealed within doors when fully lowered. Wrap-around bumpers with overrides at front and rear. Twin bucket seats, adjustable for reach, upholstered in finest quality Vaumol leather over Dunlopillo foam rubber cushions. Three-section instrument panel. Windshield rail and panel in mat-grained finish to eliminate reflection. Comprehensive instrumentation with 5-in. revolution counter, incorporating an electric clock, and 5-in. 160 m.p.h. speedometer, incorporating total and trip distance recorder, positioned in front of driver. Central panel contains separate instruments for electrically operated oil pressure, water temperature, fuel gauge with low-level warning light, and ammeter, together with a row of labelled tumbler switches controlling ancillary equipment. Separate housing beneath panel contains a radio and twin speakers (optional extra) together with an ashtray. When no radio is fitted, the speaker grilles are retained and the radio control panel aperture is blanked off with an escutcheon. Panel in front of passenger contains an open-fronted glove compartment and grab-handle. Three-spoked polished-alloy lightweight steering wheel with wood rim and central horn push. Wide-angle vertically-adjustable rear-view mirror incorporating anti-dazzle secondary mirror position. Deep pile carpets over thick felt underlay. Luggage accommodation provided in rear of car with access via a hinged-panel controlled from inside the car.

BODY CONSTRUCTION: Stressed shell all steel body of unique patented monocoque construction. Front subframe of square section steel tubing carries engine unit, suspension and forward hinged front section.

BRAKES: Dunlop bridge-type 4-wheel disc brakes, featuring quick change pads. Front brakes fitted on wheel hubs, rear brakes fitted inboard. Bellows-type brake servo operating directly onto brake pedal. Pedal operates twin master cylinders through a compensator device which divides the system into two entirely independent hydraulic systems to front and rear brakes. Centrally positioned self adjusting handbrake operates on rear wheels only. Brake fluid level warning light operates on both systems.

DIMENSIONS (Principal): Wheelbase, 8 ft. 0 in.; track, front and rear, 4 ft. 2 in.; over-all length, 14 ft. 7 1/16 in.; over-all width, 5 ft. 5 1/4 in.;

over-all height, 4 ft. 0 in.; ground clearance (laden), 5 1/2 in.; dry weight, 2,464 lbs. approx.

ELECTRICAL EQUIPMENT: Lucas 12-volt system. Large capacity battery giving 57 amp./hour at 10-hour rate with current voltage control. Ventilated dynamo. Eight fuse control box, fully labelled, located behind hinged central instrument panel for ease of access. Side lamps. Headlamps with hand-operated dimmer-switch on instrument panel. Separate lever actuating headlamp flashing. Separate stop, tail, direction and reflector units mounted in a single assembly. Rear number plate lamps. Self-cancelling, flashing direction indicators and warning light on panel. Instruments and labelled switches illuminated by internal floodlighting controlled by a two-position dimmer-switch. Map reading light. Interior light. Twin-blended note horns. Triple-blade, two-speed, self-parking windshield wiper unit. Electrically operated windshield washers. Cigarette lighter with luminous socket. Starter motor. Vacuum and centrifugal automatic ignition control. Oil coil ignition. Wiring harness in quickly detachable front body section connected to main circuits through an eight pin connector mounted on engine compartment bulkhead.

ENGINE: Six cylinder twin overhead camshaft 3.8 litre XK Jaguar "S" type engine. 87 mm. bore by 106 mm. stroke (3.425 in. x 4.1732 in.). Cubic capacity 3,781 c.c. (230.6 cu. in.). Compression ratio 9:1. Power output (9:1). 265 b.h.p. at 5,500 r.p.m.; torque: 260 ft. lbs. at 4,000 r.p.m. Three S.U. carburetors, type H.D.8 with manual choke control. Forced lubrication by submerged pump system incorporating a full flow filter. Chrome iron cylinder block fitted with dry type cylinder liners. Special "straight port" cylinder head of high tensile aluminum alloy featuring hemispherical combustion chambers and twin overhead camshafts operating large valves of 70° including angle. Aluminum alloy pistons. Steel connecting rods fitted with lead indium big end bearings, 2 3/4 in. diameter counterweighted crankshaft carried on seven large lead indium bearings. Pressurized cooling system with thermostatically controlled electrically driven fan.

FUEL SUPPLY: 16 3/4 gallon tank capacity. Lucas electric pump. Gas filter incorporated into fuel line and located in engine compartment.

HEATING AND DEMISTING: High-output fresh air heating and multi-point windshield demisting system incorporating a two-speed fan controlled by switch on panel. Temperature and volume of air controls on panel. Ducts direct air to each side of compartment.

JACKING: Centrally located jacking posts enable the front and rear wheels on either side of the car to be raised simultaneously by means of the jack provided.

SPARE WHEEL AND TOOLS: The spare wheel is carried beneath the trunk floor in a separate compartment and is readily accessible. Tool kit housed in the spare wheel compartment.

SUSPENSION: Independent front suspension incorporating transverse wishbones with torsion bars controlled by telescopic hydraulic dampers. Anti-roll bar fitted to lower wishbones. Fully independent rear suspension incorporating, on each side, a lower transverse tubular link pivoted at the wheel carrier and subframe adjacent to the differential case and, above this, a halfshaft universally jointed at each end. These serve to locate wheel in a transverse plane. Longitudinal location is provided by the rubber mountings locating the sub-assembly in the body structure and by a radius arm between the lower link and a mounting point on the body structure. Twin coil springs, each enclosing a telescopic hydraulic damper provide the suspension medium. The whole assembly together with the differential unit is carried in an easily detachable subframe which is located in the body structure by rubber mountings.

STEERING: Rack and Pinion, 16 in. steering wheel with separate adjustments for height and reach. 2 3/4 turns from lock to lock. Turning circle, 37 ft.

TRANSMISSION: Manually-operated four-speed, single helical synchromesh gearbox. Centrally positioned gear-shift lever. Synchromesh on top, third and second gear ratios. Borg & Beck 10 in. single dry-plate clutch with hydraulic operation. Hardy-Spicer Needle-Bearing propeller shaft. Hypoid rear axle fitted with limited-slip differential. Ratios 3.31:1. Optional axle ratios are available.

WHEELS AND TIRES: Wire-spoked wheels with center-lock hubs fitted with Dunlop 6.40 x 15 type RS.5 tires and tubes. Optional tire and wheel equipment available for racing: 6.00 x 15 front, 6.50 x 15 rear on special wheels.

3.8 SEDAN

SEATING DIAGRAMS & GENERAL DIMENSIONS

SPECIFICATIONS

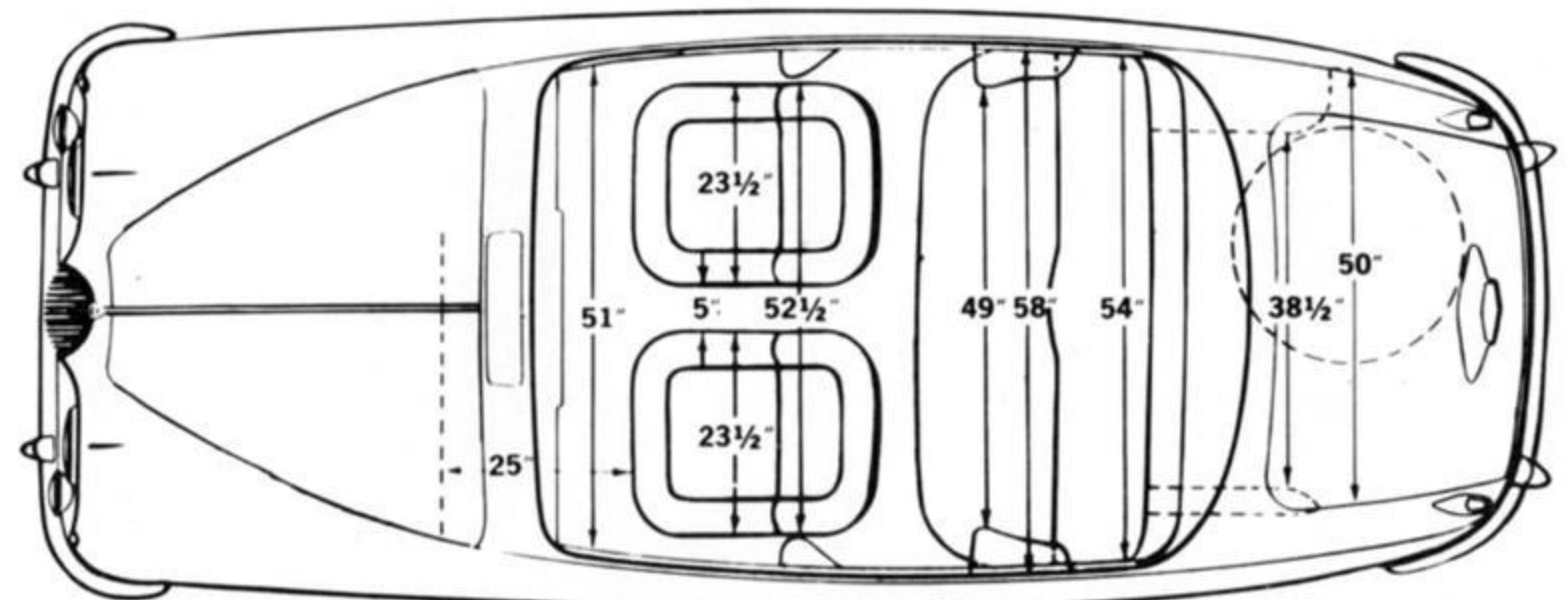
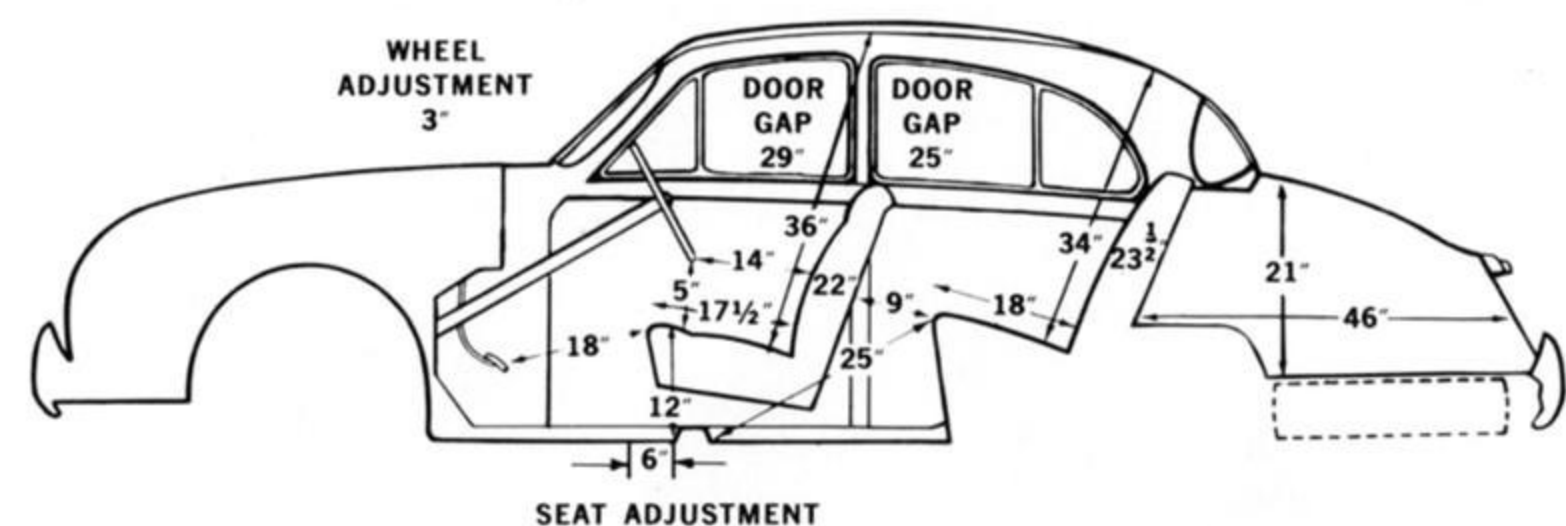

BODY AND APPOINTMENTS: All-steel four-door five-passenger sedan. Integral body-chassis construction. Large windshield with slim pillars and semi-wrap-around rear window for maximum visibility front and rear. The semi-wrap-around windshield does not interfere with ease of entry and exit. Wide view rear mirror. Special door handles incorporating push buttons designed to prevent freezing up in extremely cold conditions. Seats upholstered in finest quality Vaumol leather hide over deep Dunlopillo foam rubber cushions. Front bucket seats adjustable for reach. Polished figured walnut instrument panel features 5 in. revolution counter with electric clock and 5 in. speedometer positioned directly in front of driver and separate instruments for oil pressure, water temperature, fuel gauge with warning light and ammeter. Instrument panel also contains a central map compartment and, on the passenger's side, a glove compartment with an interior light and lockable lid. Separate housing beneath instrument panel contains a radio and speaker (optional extra), together with the heater controls and a very large ashtray. When no radio is fitted, the speaker grille is retained and the radio control panel aperture is blanked off with an escutcheon. Two-spoke steering wheel and semi-circular horn ring. Front and rear doors incorporate large pockets and armrests which, on the rear doors, also contain ashtrays. Central folding armrest in rear compartment. Sun visors. Deep pile carpets over thick felt underlay. Heavy duty wrap-around bumpers with overrides.

BRAKES: Dunlop bridge-type 4-wheel disc brakes, featuring quick change pads, vacuum servo assisted. Self-adjusting handbrake mounted at floor level. Disc diameter, 11 1/4 in.

DIMENSIONS (Principal): Wheelbase, 8 ft. 11 3/8 in.; track front, 4 ft. 7 in.; track rear, 4 ft. 5 3/8 in.; overall length, 15 ft. 3/4 in.; overall width, 5 ft. 6 3/4 in.; overall height, 4 ft. 9 1/2 in.; ground clearance, 7 in.; turning circle, 33 ft. 6 in.; dry weight, 3,136 lbs. approx.

ELECTRICAL EQUIPMENT: Lucas 12-volt battery, 64 amp./hour at 10-hour rate with current voltage control. Ventilated dynamo. Sidelamps with driver-visible ruby glass inserts to warn of bulb failure faired into tops of front fenders. Headlamps controlled by foot-operated dimmer-switch. Separate lever for actuating headlamp flashing. Separate stop, tail, direction and reflector units mounted in a single assembly. Reversing lamp. Self-cancelling, flashing direction indicators with warning lights. Instruments and labelled switches illuminated by internal flood lighting controlled by a two-position dimmer-switch. Concealed map reading lamp. Twin courtesy lights above the center door pillar and twin interior lights in the corners of the rear compartment. Cigarette lighter with luminous socket. Twin-blended note horns. Twin-blade, two-speed, self park-

ing windshield wipers. Electrically operated windshield washers. Combined handbrake and brake fluid level warning light.

ENGINE: Special 6-cylinder 3.8-litre XK engine. Twin S.U. type H.D.6 horizontal carburetors with electrically controlled automatic choke and twin exhaust system. Develops 225 b.h.p. at 5,500 r.p.m. 70° twin overhead high-lift camshafts driven by two-stage roller chain. 3.42 in. bore x 4.17 in. stroke. Cubic capacity 3,781 c.c. (230.6 cu. in.) Cooling by pump and fan with by-pass thermostat control. Forced lubrication by submerged pump system incorporating full-flow filter. High grade chrome iron cylinder block. Cylinder head of high tensile aluminum alloy with hemispherical combustion chambers, developed from "C" and "D" type racing heads. Aluminum alloy pistons. Steel connecting rods. 2 3/4" diameter counterweighted crankshaft carried in seven large steel-backed precision bearings.

FUEL SUPPLY: 14 1/2 gallon tank capacity. S.U. electric pump.

HEATING AND DEMISTING: High-output heating system incorporating windshield demisting. Separate heating duct to rear compartment. Two-speed fan controlled by switch on instrument panel.

JACKING: Exterior jacking posts, on both sides which enable the car to be lifted with a minimum of effort by means of the jack provided.

LUGGAGE ACCOMMODATION: Ample luggage accommodation is provided in a capacious rear trunk with an automatic light. 13 1/2 cubic feet of luggage space available.

REAR AXLE: Limited-slip differential fitted as standard equipment.

SPARE WHEEL AND TOOLS: The spare wheel is carried beneath the trunk floor in a separate compartment and is readily accessible. Kit of tools, jack and wheelbrace.

STEERING: Burman recirculating ball-type steering with 17" diameter adjustable two-spoke steering wheel. 4.3 turns from lock to lock. Power assisted steering, optional extra.

SUSPENSION: Independent front suspension incorporating semi-trailing wishbones and coil springs with telescopic shock absorbers. Trailing link rear suspension by cantilever semi-elliptic springs, radius arms and telescopic shock absorbers.

TRANSMISSION: (A) MANUALLY OPERATED GEARBOX WITH OVERDRIVE. Four-speed single helical synchromesh gearbox. Centrally positioned gear-shift lever. Gear ratios: 1st and reverse, 12.73; 2nd, 7.01; 3rd, 4.84;

4th, 3.77; Overdrive, 2.93. Borg & Beck 10" single dry-plate clutch with hydraulic operation. Hardy-Spicer propeller shaft. Hypoid rear axle. (B) AUTOMATIC TRANSMISSION. Borg-Warner Automatic Transmission with driver-controlled intermediate gear. Gear ratios: Low range from 8.16 to 17.6; intermediate range from 5.08 to 10.95; top (direct drive), 3.54. Hardy-Spicer propeller shaft. Hypoid rear axle. Gear selector mounted on steering column.

WHEELS AND TIRES: Pressed steel bolt-on disc wheels fitted with Dunlop 6.40 x 15 in. type RS.5 low-pressure tires. Spare wheel and tire. Center-lock wire wheels available as optional extra.

MARK X SEDAN

SEATING DIAGRAMS & GENERAL DIMENSIONS

SPECIFICATIONS

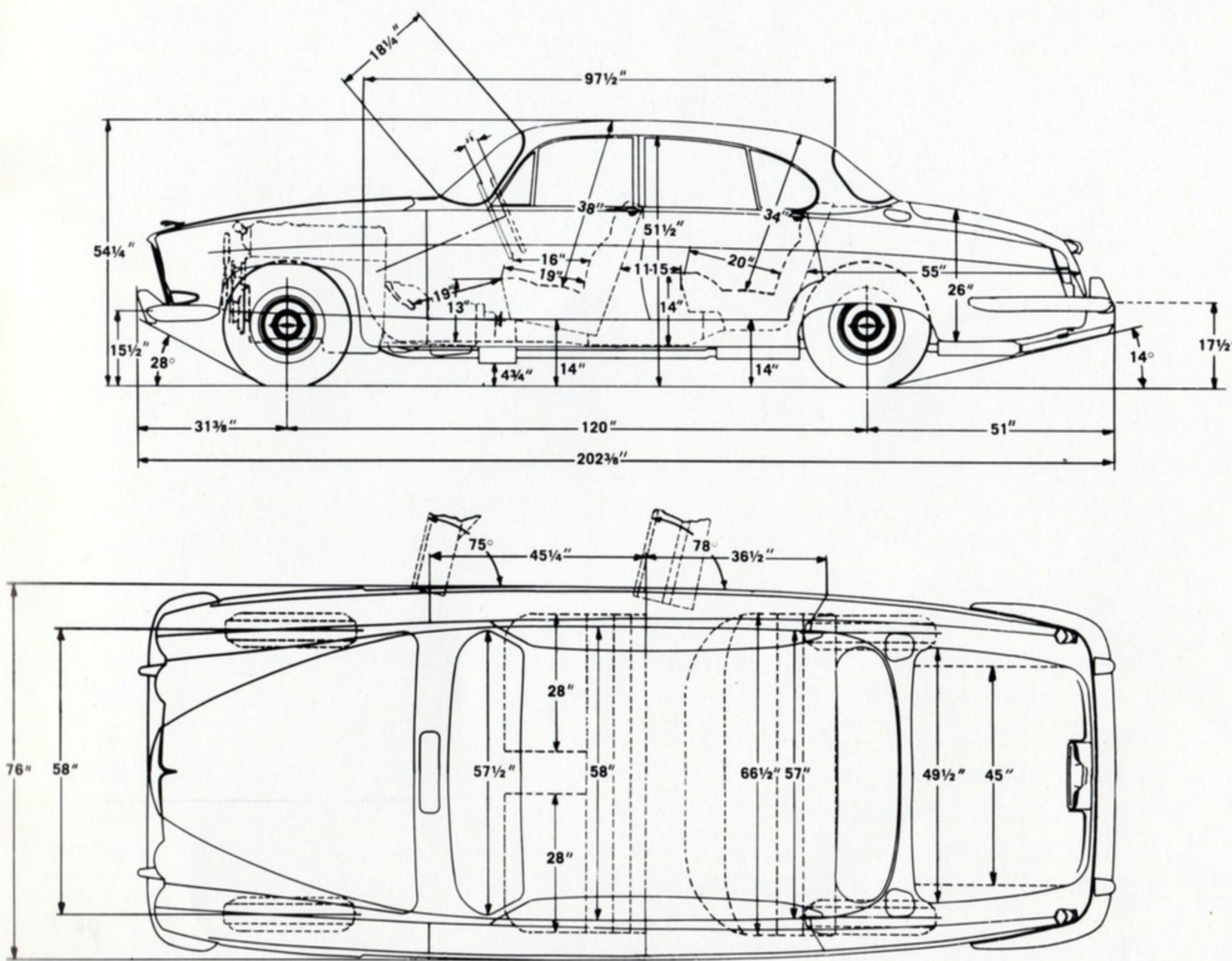

BODY AND APPOINTMENTS: All-steel four-door five-seater of monocoque construction providing maximum rigidity with minimum weight. Large semi-wrap-around windscreen with slim pillars and semi-wrap-around rear window for maximum visibility front and rear. The semi-wrap-around windscreen does not interfere with ease of entry and exit. Wide view rear mirror. All four doors hinged at the forward end and initial opening is assisted by torsion bars on front doors and springs on rear doors. Chromium plated window frames on all four doors. Special door handles incorporating push buttons designed to prevent freezing up in extremely cold conditions. Seats upholstered in finest quality Vaumol leather hide over deep Dunlopillo foam rubber cushions. Reclining type front seats, fitted with central folding armrests, adjustable for reach. Reclining seat mechanism provides wide range of positions. Seats incorporate flush fitting tables and ashtrays in the backs of the squabs. Each table when opened reveals a large rectangular mirror. Polished figured walnut instrument panel features revolution counter and speedometer positioned directly in front of driver and separate instruments for oil pressure, water temperature, fuel gauge and ammeter. Instrument panel contains on the passengers side, a glove compartment with an interior light and lockable lid. A large parcel shelf runs the full width of the car. Separate housing beneath the parcel shelf contains a radio and speaker (optional extra) together with the heater controls and a very large ashtray. When no radio is fitted, the speaker grille is retained and the radio control panel aperture is blanked off with an escutcheon. Two spoke steering wheel and semi-circular horn ring. Front and rear doors incorporate armrests. Central folding armrest in rear compartment. Sun vizors. Deep pile carpets over thick felt underlay. Heavy duty wrap-around bumpers with over-riders. Counterbalanced forward opening hood.

BRAKES: Dunlop bridge-type disc brakes featuring quick change pads, are fitted to all four wheels. Front brakes fitted on wheel hubs, rear brakes fitted inboard of halfshafts adjacent to differential unit. Bellows type brake servo operating directly on to brake pedal. Pedal operates twin master cylinders through a compensator device which divides the system into two entirely independent hydraulic systems to front and rear brakes. Self-adjusting handbrake. Brake fluid warning light operates on both systems, and is also actuated by application of handbrake.

PRINCIPAL DIMENSIONS: Wheelbase 120 in., track front and rear 4 ft. 10 in., overall length 16 ft. 10 in., overall width 6 ft. 4 in., overall height 4 ft. 6 1/2 in. laden. Turning circle 37 ft. Ground clearance 6 1/2 in. Weight dry 3920 lbs. approx.

ELECTRICAL EQUIPMENT & INSTRUMENTS: Lucas 12 volt battery. 60 amp/hour at 10 hour rate with current voltage control. Ventilated generator. Parking lights. Four headlamps controlled by foot operated dip-

switch. Separate lever for actuating headlamp flashing. Separate stop/tail, direction and reflector units mounted in a single assembly. Reversing lamp. Self cancelling flashing direction indicators with warning lights. Instruments and labelled switches illuminated by internal flood-lighting controlled by a two position dimmer switch. Concealed map reading lamp beneath screen rail in front compartment. Twin courtesy lights above the center door pillar operated either manually by switch on instrument panel or automatically by any of the four doors. Trunk illumination controlled by automatic switch. Cigarette lighter with luminous socket. Twin blended note horns. Twin-blade, two-speed, self-parking windshield wipers. Electrically operated windshield washers. Starter motor. Vacuum and centrifugal automatic ignition advance. Oil coil ignition. 5 in. diameter speedometer incorporating total trip and distance recorder. 5 in. diameter electrically driven revolution counter with electric clock. Ammeter, electrically operated oil pressure gauge, water temperature gauge, fuel gauge, combined handbrake and brake fluid level warning light.

ENGINE: Six cylinder twin overhead camshaft 3.8 litre XK Jaguar "S" Type engine. 3.43 in. bore x 4.17 in. stroke. Cubic capacity 230.6 cu. in. Compression ratio 9 to 1 (8 to 1 optional). Power output (9 to 1): 265 b.h.p. at 5,500 r.p.m., torque: 260 ft. lbs. at 4,000 r.p.m. Three S.U. carburetors type HD. 8 with automatic choke control. Forced lubrication by submerged pump system incorporating a full flow filter. Chrome iron cylinder block fitted with dry type cylinder liners. Special 'straight port' cylinder head of high tensile aluminum alloy featuring hemispherical combustion chambers and twin overhead camshafts operating large valves of 70° included angle. Aluminum alloy pistons. Steel connecting rods fitted with lead indium big end bearings, 2 3/4 in. diameter counterweighted crankshaft carried on seven large lead indium bearings. Pressurized cooling system with thermostatic control.

FUEL SUPPLY: Twin gasoline tanks—one in each rear fender—with a total capacity of 24 gallons. Each tank houses a submerged type electrical pump operating on the recirculation principle. Filter incorporated in fuel line to carburetors. Tank changeover switch mounted on fascia panel and fuel gauge records contents of tank in use. The separate fillers to each tank are concealed beneath lockable covers.

HEATING & DEMISTING: Completely new heating system capable of high temperature and volume supply to front and rear compartments independently. Layout also incorporates an extremely efficient separate system of windshield demisting. Air intake, distribution, and temperature control are all vacuum servo operated.

JACKING: Exterior jacking posts, on each side, enable the car to be lifted with the minimum effort by means of the jack provided.

LUGGAGE ACCOMMODATION: Ample luggage accommodation is provided in an extremely large rear trunk of 27 cubic feet capacity. Illumination is provided by an automatically controlled interior light operated by opening trunk lid which is counterbalanced by torsion bars for ease of operation. Whole of trunk is fully trimmed and spare wheel is provided with a cover to protect luggage.

SPARE WHEEL & TOOLS: The spare wheel is carried vertically in the luggage compartment and is readily accessible. A comprehensive set of tools is also supplied in a special container, and this together with wheel changing equipment is fitted behind the spare wheel.

STEERING: Power-assisted re-circulating ball type steering. Power assistance is applied by hydraulic pressure from a pump driven from the rear of the generator. 17 in. diameter steering wheel adjustable for reach.

SUSPENSION-FRONT: Independent front suspension incorporating semi-trailing wishbones and coil springs with telescopic shock absorbers. Anti-roll bar located between lower wishbones.

SUSPENSION-REAR: Fully independent rear suspension incorporating on each side, a lower transverse tubular link pivoted at the wheel carrier and subframe adjacent to the differential case and, above this, a halfshaft universally jointed at each end. These serve to locate the wheel in a transverse plane. Longitudinal location is provided by the rubber mountings locating the sub-assembly in the body structure and by radius arms between the lower link and a mounting point on the body structure. Twin coil springs, each enclosing a telescopic hydraulic damper provide the suspension medium. The whole assembly together with the differential unit is carried in an easily detachable subframe which is located in the body structure by rubber mountings.

TRANSMISSION: A. (Manually operated gearbox). Four speed single helical synchromesh gearbox. Change speed lever on floor between front seats. Gear ratios: 1st. and reverse, 11.95, 2nd. 6.58, 3rd. 4.54, 4th. 3.54. Borg and Beck 10 in. single dry plate clutch with hydraulic operation. Hardy Spicer propeller shaft. Hypoid rear axle. B. (Overdrive model). As above, with addition of a Laycock de Normanville Overdrive controlled by a lever mounted on the steering column. Gear ratios: 1st. and reverse, 12.73, 2nd. 7.01, 3rd. 4.84, Top 3.77, Overdrive 2.93. C. (Automatic Transmission model). Borg Warner Automatic Transmission system with driver controlled intermediate gear hold. Gear ratios: Low 17.6-8.16, Intermediate 10.95-5.08, Direct top 3.54. Gear selector lever on steering column. Hardy Spicer propeller shaft. Hypoid rear axle.

WHEELS & TIRES: Pressed steel bolt-on disc wheels fitted with Dunlop 7.50 x 14 in. Road Speed tires.

PARTS FOR YOUR JAGUAR

Jaguar Cars Inc., U. S. subsidiary of Jaguar Cars Ltd., of Coventry, England, wishes to call attention to the fact that Jaguar was one of the first imported motor cars to be sold in the United States in significant numbers.

In the early 1950's, therefore, Jaguar began an intensive study of ways and means of ensuring an adequate supply of parts to its Distributors and Dealers and, finally, to Jaguar owners in North America.

Jaguar Cars Inc. is proud to say that its prolonged efforts to improve the direct flow of parts from factory to point-of-service have achieved gratifying results.

Today, Jaguar Distributors and Dealers carry parts stocks ample to furnish service to the Jaguar cars registered in their territories. A factory Parts Depot is located in Long Island City, only minutes away from the major airline terminals of New York. A similar Parts Depot is maintained in Canada by Jaguar Cars (Canada) Ltd.

Time, energies and expense have not been spared by Jaguar in trying to provide Jaguar owners with the highest standard of service available to an imported car driver in the continent of North America.

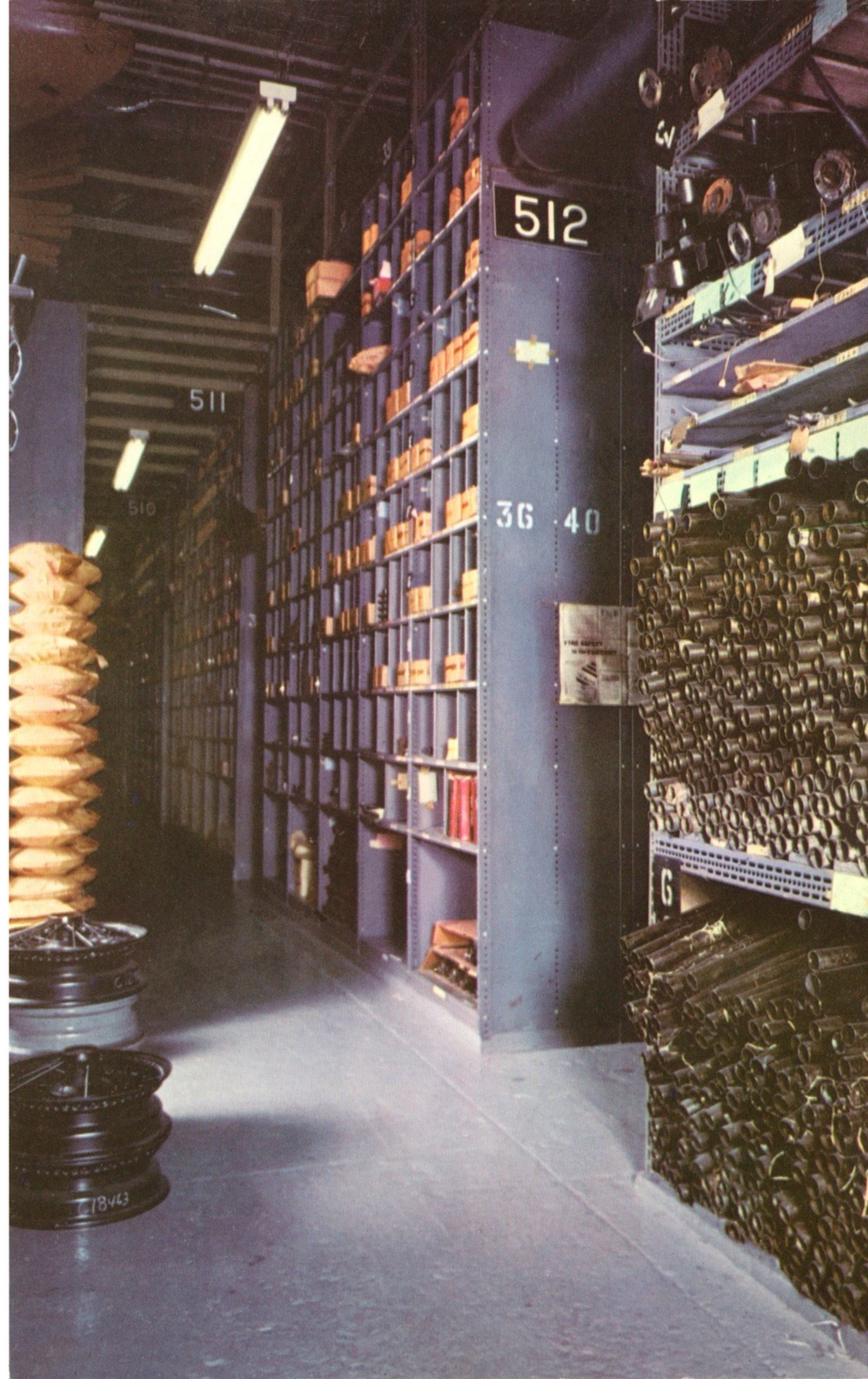

The issue of this catalog does not constitute an offer. Jaguar Cars Ltd. reserves the right to amend specifications at any time without notice.

JAGUAR CARS INC., 32 EAST 57th STREET, NEW YORK 22, N. Y.

