

**RH™ SERIES**



THE INTERNATIONAL® RH™ SERIES.



# THE INTERNATIONAL<sup>®</sup> RH<sup>™</sup> SERIES.

The International RH Series is built to redefine the rules for productivity in local and regional haul applications. It's designed based on the feedback of hundreds of hard-working drivers as part of our DriverFirst<sup>™</sup> philosophy, with a tight turning radius and the superior visibility needed to maneuver in tight spaces. It features an ergonomically advanced interior and instrument panel to enhance driver productivity and control. The RH Series is powered by the International A26, a 12.4L engine designed to deliver optimal uptime as well as class-leading fuel efficiency, reduced weight and quiet operation. The RH Series from International - the truck you need when you need optimal maneuverability for your deliveries, and optimal productivity for your business.



**RH**  
INTERNATIONAL



**A DRIVER'S TRUCK THAT  
DELIVERS WHERE YOU NEED IT MOST.**



## RH SERIES CONFIGURATIONS TO DELIVER FOR YOUR BUSINESS.



56" Hi-Rise Sleeper\*

56" Hi-Rise Sleeper with Roof Fairing

Day Cab with Roof Fairing

Day Cab

56" Low Roof Sleeper\*

The RH Series began with a vision to build an incredibly productive, efficient truck that's as dependable as the people who drive them. Every aspect of the RH Series design is optimized around a driver's needs, with maneuverability, efficiency, serviceability and reliability that are among the best in the industry. And the RH Series is available in a range of configurations, so you can spec an ideal match for your specific business needs.

\* Shown with optional sun visor



## A VISIBLE DIFFERENCE IN SAFETY AND PRODUCTIVITY.

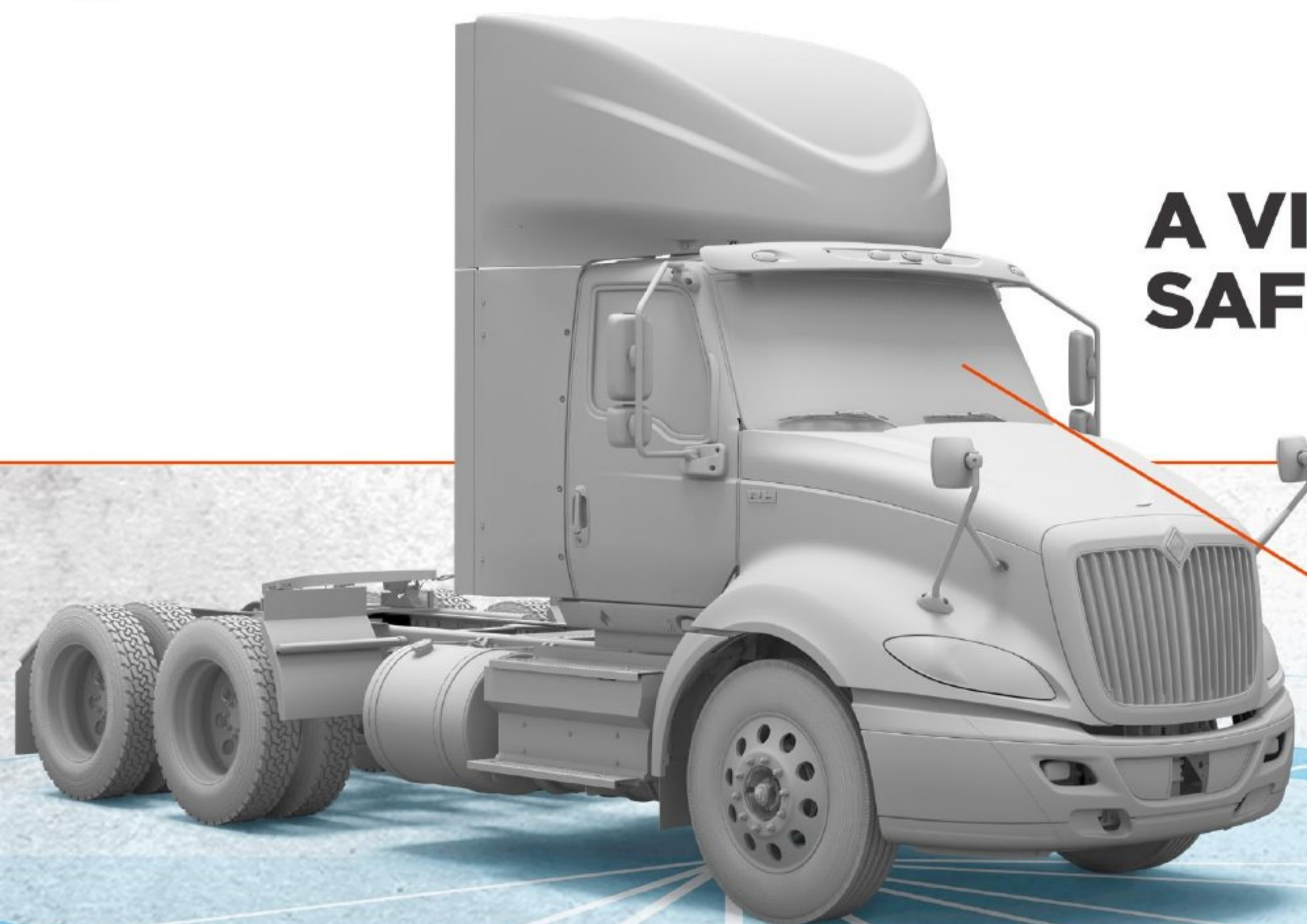

Forward visibility is among the industry's best at as little as 21'. This means objects closer to the vehicle are more visible to the driver, improving safety.

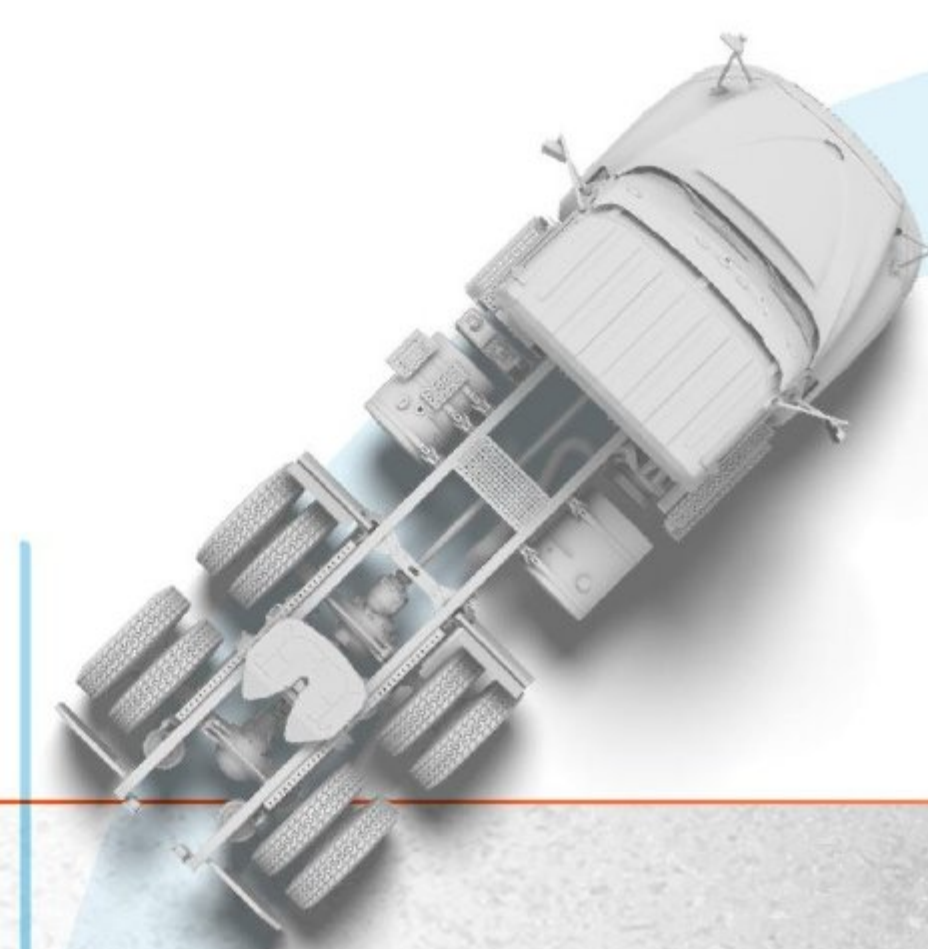

**50°**  
Inside Cut  
**27' 10"**  
Curb to Curb

TURNING RADIUS



### OUTSTANDING MANEUVERABILITY

You need optimal maneuverability to navigate through tight city streets or cramped loading docks. The RH Series is engineered to provide an inside wheel cut of up to 50° which delivers a curb-to-curb turning radius of only 27' 10", saving driver time and boosting productivity.\*

The RH Series interior was designed based on a meticulous study of interaction points between the driver and truck - everything from what a driver sees to how he moves and reacts in virtually any situation. That's why the RH Series was designed with a large swept-back windshield, optimized mirror placement and an aerodynamic sloped hood for a clearer view.

Direct Visibility

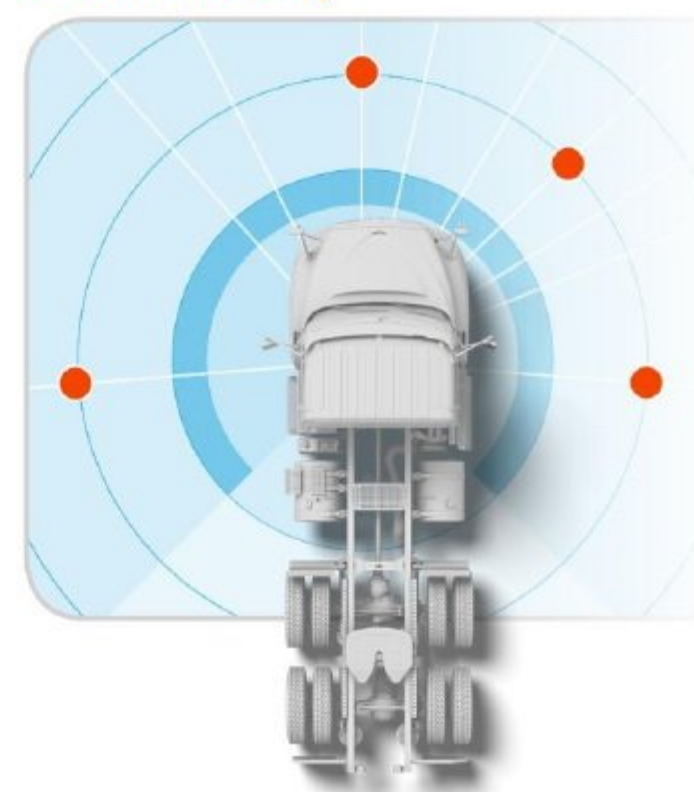

Indirect Visibility

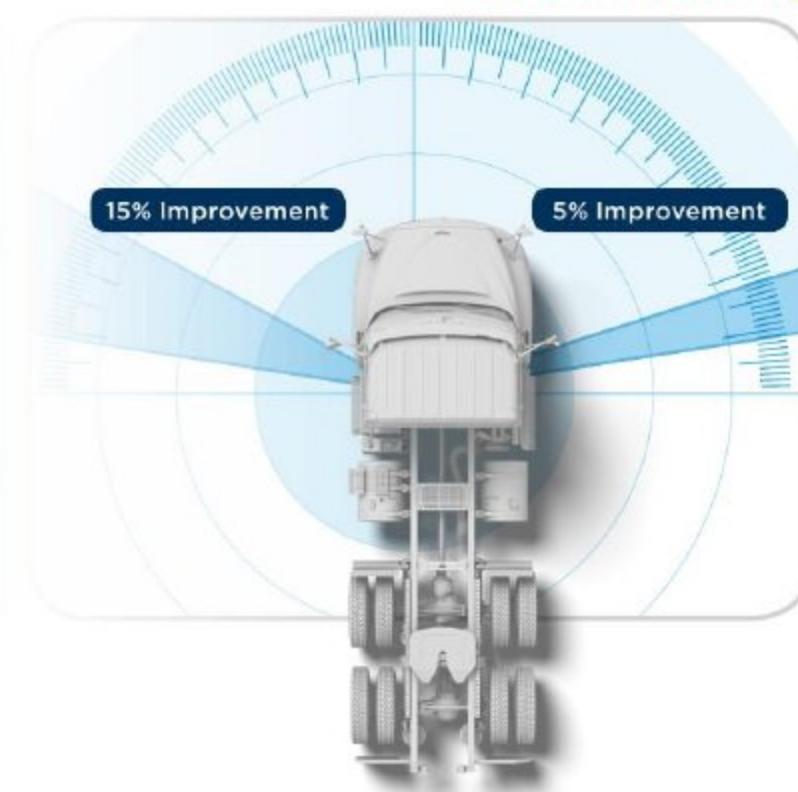

The shaded areas represent how indirect visibility has been optimized by reshaping the doors and side windows, and repositioning the cab mirrors so drivers turn their heads 15% less on the driver side and 5% less on the passenger side. This increased visibility reduces driver stress and neck strain to enhance productivity.

\*With a 152" cab to axle (wheelbase is 215")



## KEEPING YOU ON THE ROAD TO PROFITABILITY.

Uptime is more than a word in the RH Series – it's an unwavering commitment to deliver a truck that's as reliable and easy to service as the road is long.

- ▶ **Driver controls and instrumentation** are based on robust industry-standard SAE J1939 electrical architecture, with a premium gauge cluster and switches designed to keep drivers focused and maximize uptime.
- ▶ **Steering wheel control labels** are laser-etched through the thickness of the material and LED backlit for maximum durability and visibility.
- ▶ **Key interior fasteners** are exposed for more intuitive access and easier servicing.
- ▶ The available **automatic temperature control** maintains the selected cabin temperature for driver comfort.
- ▶ The **max defrost** feature in the HVAC system helps clear windows faster in colder climates, providing quicker, clearer visibility for increased uptime and less waiting.
- ▶ **Cab wiring** features a power distribution module that's located inside the cab, protected from the elements.
- ▶ The **single canister after-treatment system** is up to 60% smaller and 40% lighter than the system it replaces, with better heat management to help improve fuel economy and greater ash retention to stretch out time between service intervals. The system is also simplified for easier servicing.
- ▶ The **hood** opens wide for easy serviceability. It features torsion bar lift assist to enable lifting with one hand, and gas strut control to prevent the hood from closing too quickly.
- ▶ The easily removable **3-piece bumper** provides quick service access to front components.
- ▶ Standard **LED headlights** last longer than traditional headlamps while delivering brighter light pattern and intensity.

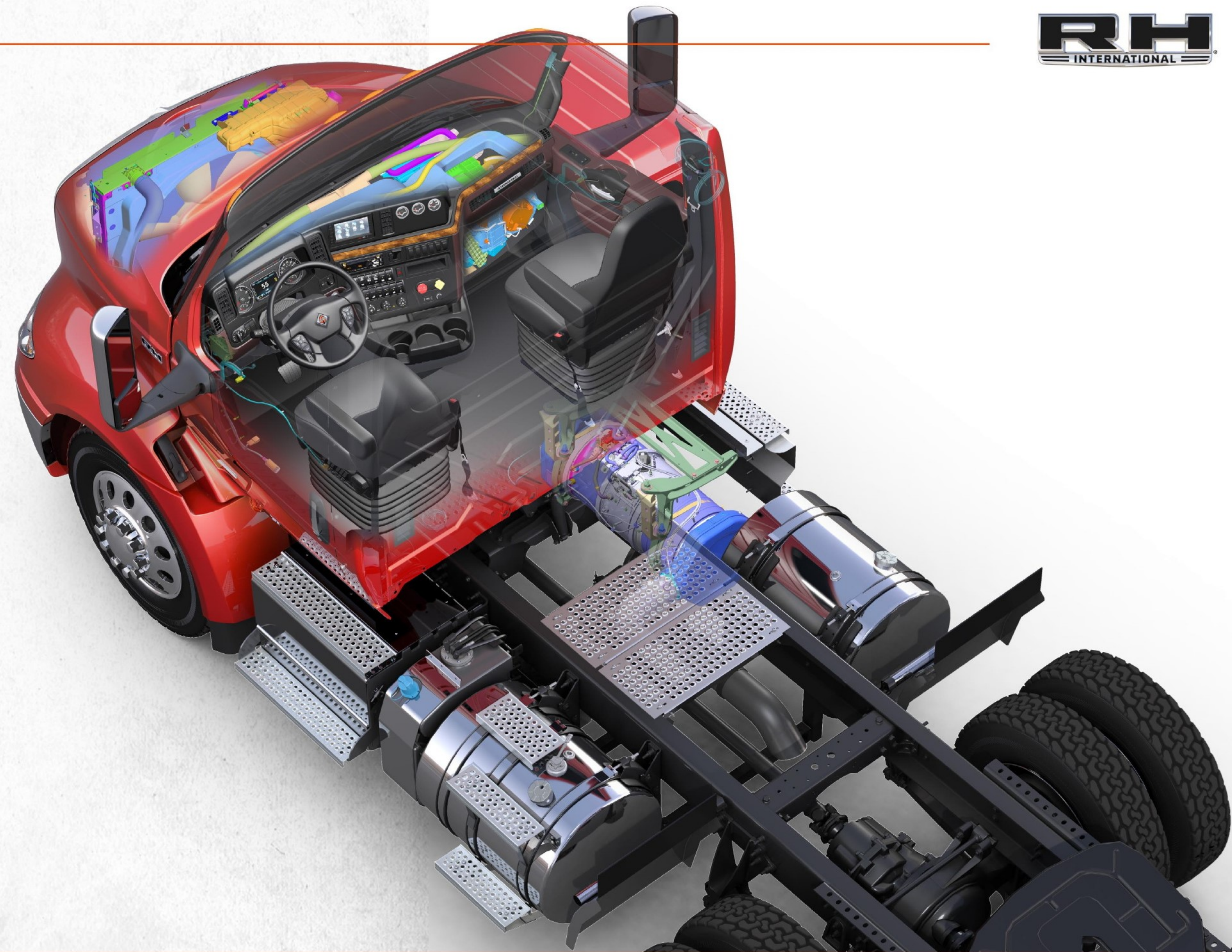

In-cab electrical panel

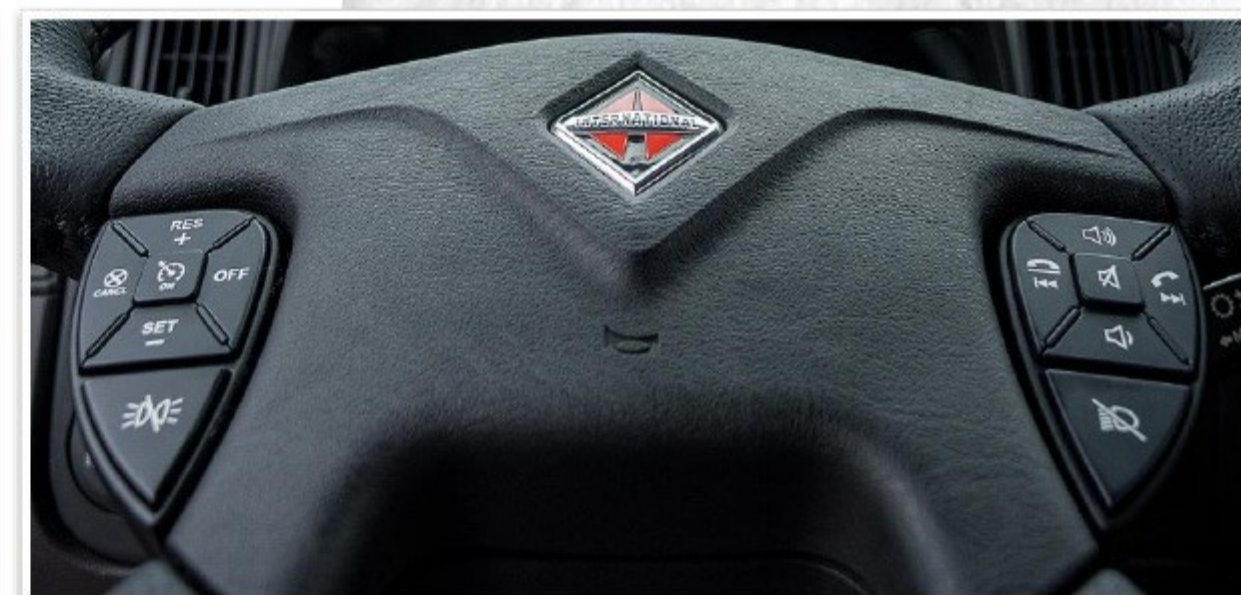

Laser-etched steering wheel controls



Single canister after-treatment system



## PUTTING THE DRIVER IN POSITION TO SUCCEED.

From the beginning, the top priority for the RH Series was to design a truck that made drivers more comfortable, alert and productive. To achieve this goal, we turned to the people who know driving best – drivers.

These professionals gave us honest, priceless input over numerous research sessions and driver clinics. Then we redesigned, fine-tuned and retested until drivers agreed, “this is the truck I’ve always wanted to drive.”

This DriverFirst™ philosophy is how the RH Series became the most driver-centric regional haul truck in its class – with more intuitive controls, enhanced visibility, a quieter cab, critical information at your fingertips and dozens of other smart features that help keep a driver performing at their best in local or regional applications.





# DRIVERFIRST™ IN EVERY DETAIL.

Every detail inside the RH Series cab has been carefully designed, measured and clinic-tested to optimally benefit the driver. The gauges are optimized so key information and alerts are precisely where they need to be for clear viewing without distraction. The standard premium gauge cluster features a customizable digital display that allows drivers to intuitively select the information they prefer in a variety of situations.



The standard **premium gauge cluster** provides a wealth of information for the driver, including:

- ▶ Real-time fuel economy
- ▶ Axle load\*
- ▶ Custom gauge settings\*
- ▶ Safety indicators\*
- ▶ Digital speedometer
- ▶ Tire pressure\*

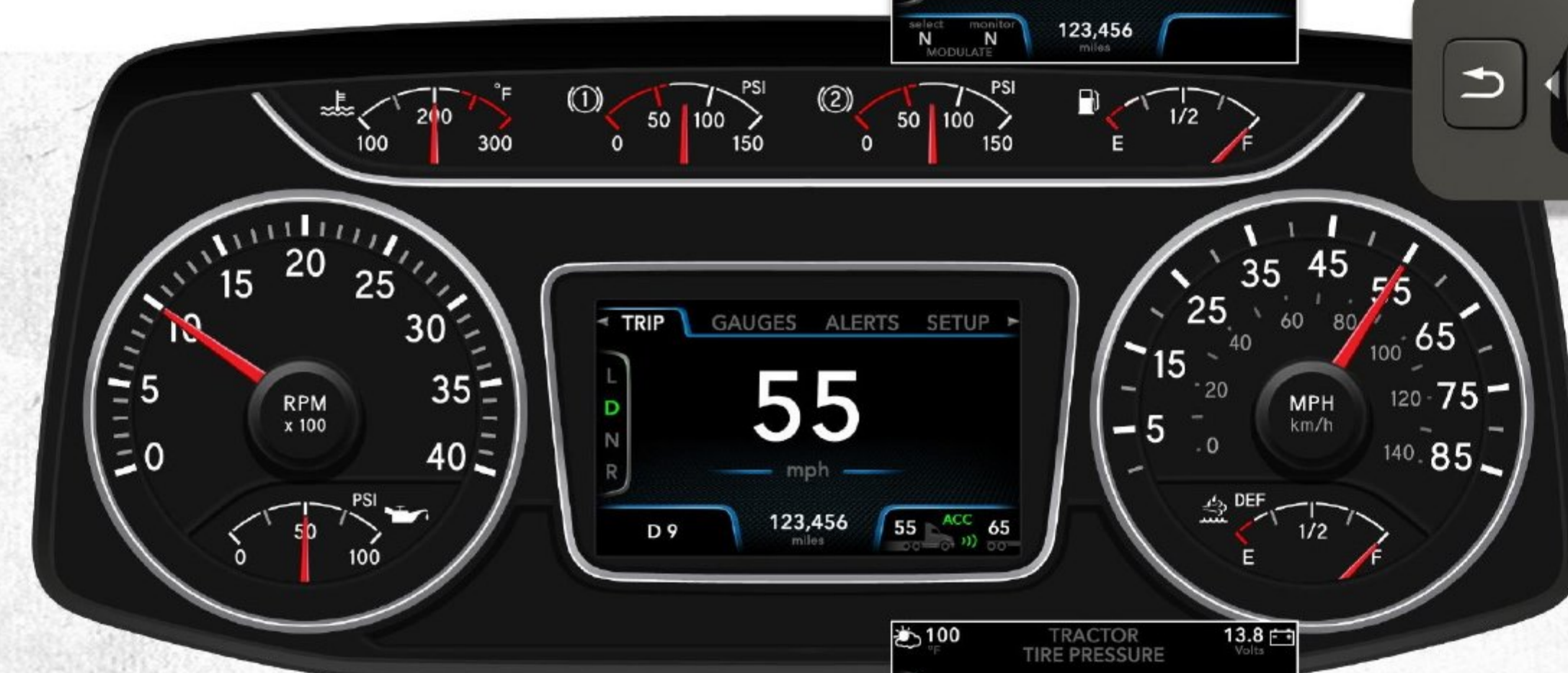

Intuitive controls allow you to easily navigate between digital screens.

**Back Button** - navigate to previous page/sub category and then to main home screen

**Navigation Button** - navigate up and down to move within categories, navigate left or right to access the main menu and to move from one category to another

**OK/Reset Button** - select a highlighted category or hold for 3 seconds to reset the item



Driver safety is always a priority. That's why the RH Series includes standard Bendix® Wingman® Fusion™ system with collision mitigation technology, adaptive cruise control, lane departure warning (pictured here), over-speed alert and stationary vehicle braking. You can also select from a number of proven stand-alone safety systems to meet your specific needs. Bendix Wingman Advanced™ and Wabco OnGaurdACTIVE™ TM are also available.

The color, illumination, legibility and even the type font and size of gauges is designed to deliver optimal viewing in varying light conditions, maximizing alertness and minimizing eye fatigue.

\* When added with optional feature code for required sensors.

## EASIER SHIFTING



- ▶ The innovative stalk shifter is mounted on the steering column, allowing you to easily reach and smoothly operate shifting and engine braking while keeping your eyes on the road and your hands on the wheel.



# A NEW BREED OF UPTIME.

THE A26 IS PACKED WITH LIGHTWEIGHT, HARD-WORKING PERFORMANCE FOR REGIONAL HAUL APPLICATIONS.

A26 engine

The International A26 represents the latest and greatest thinking in reliable, efficient performance. Producing up to 475 HP and 1750 lb.-ft. of torque in the RH Series, the 12.4L A26 delivers proven technology that has been carefully engineered to minimize weight while delivering uncompromising uptime, class-leading fuel efficiency and quieter operation.

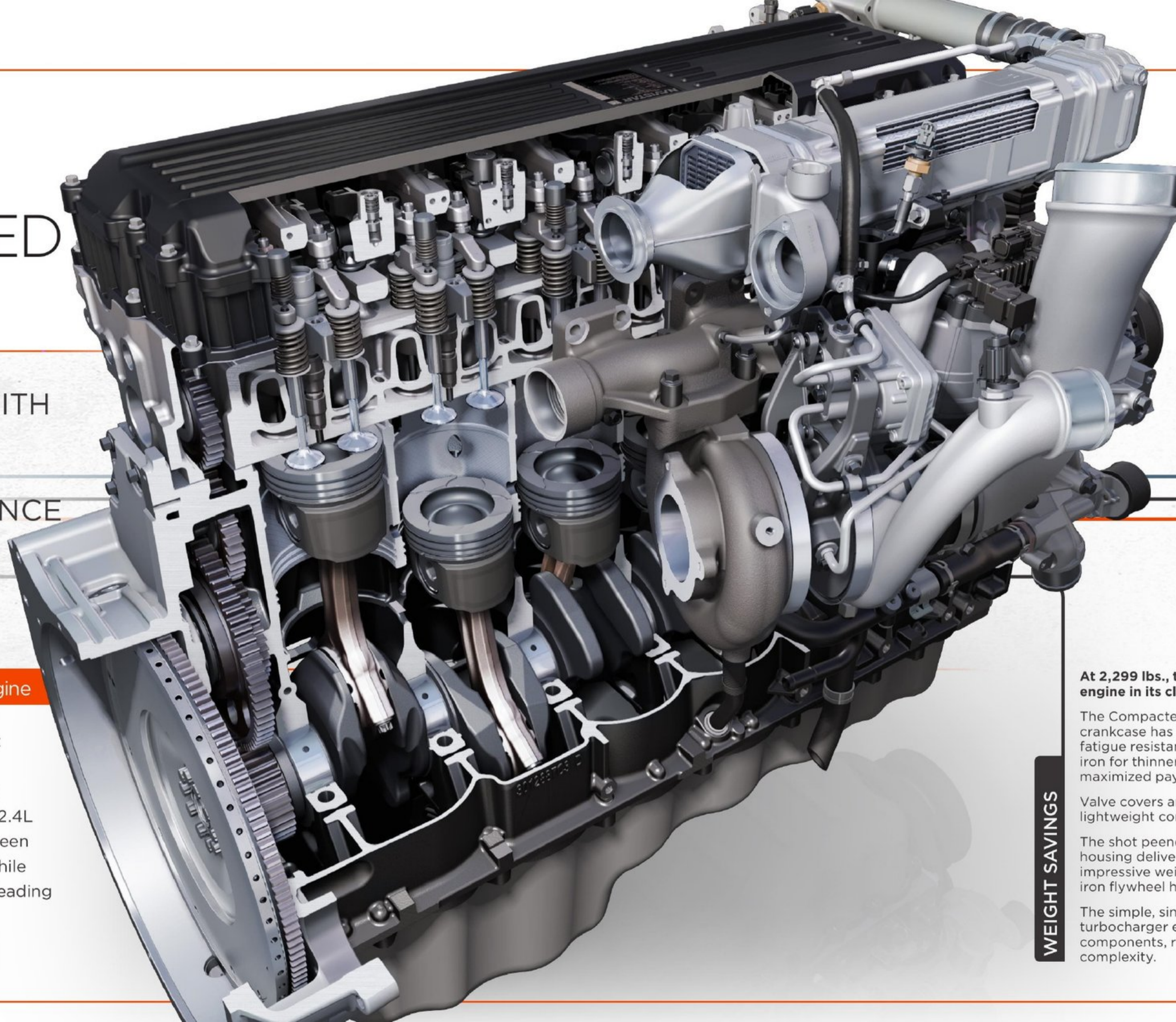

## UPTIME

### Every component is engineered to maximize uptime:

Larger piston pins, connecting rods and bushings optimize load distribution for enhanced durability.

The variable geometry turbocharger features a super-strong titanium compressor wheel that delivers superior fatigue life over aluminum designs, with simplified single stage design to reduce complexity and enhance reliability.

The 2500 bar High Pressure Common Rail (HPCR) fuel system has proven its reliability over 6 years of testing, and has been in production on the MAN D38 15-liter engine since 2015.

Smaller piston cooling jets increase oil pressure to improve lubrication and engine durability. Exposing less oil to hot pistons also reduces oil oxidation to improve oil drain intervals.

## WEIGHT SAVINGS

### At 2,299 lbs., the A26 is the lightest engine in its class:

The Compacted Graphite Iron (CGI) crankcase has greater strength and fatigue resistance than traditional gray iron for thinner walls, reduced weight and maximized payload.

Valve covers are built of durable, lightweight composite instead of aluminum.

The shot peened aluminum flywheel housing delivers high strength with impressive weight savings over traditional iron flywheel housings.

The simple, single stage design of the turbocharger eliminates several major components, reducing weight and complexity.

## NOISE REDUCTION

### The A26 is packed with noise-reducing features:

The uniquely sculpted crankcase significantly dampens vibration.

The HPCR fuel system delivers multiple injection events for smooth, quiet operation.

The oil pan and crankcase are isolated via a specially designed rubber gasket that absorbs vibration before it can get amplified through the oil pan.

Sophisticated calibration and programming are specifically designed to reduce engine noise.

The 6-blade fan features fewer blades for quieter operation.

## FUEL EFFICIENCY

### Engineered to deliver up to 5% greater fuel economy:

Maximized fuel injection pressure from the 2500 bar (36,300 psi) HPCR Fuel System reduces both fuel consumption and emissions.

The cylinder head coolant passages are 50% less restrictive to reduce parasitic loss to the water pump.

A simplified air management system with a variable geometry turbocharger turbo delivers optimal fuel economy and performance.

An oil cooler thermostat bypass allows oil to bypass the oil cooler in colder weather to improve fuel economy.



Engine braking power is increased by up to 67% for confident braking performance, particularly at low- to mid-RPMs and at higher altitudes



Start confidently down to -40°F with available oil heater, coolant heater and cold start system



Advanced engine control software developed by A26 engineers for the single engine control module allows calibration enhancements to reach customers in days instead of months





Horsepower [BHP @ RPM] 365 - 475 @ 1,700

Torque [LB-FT @ RPM] 1,250 - 1,750 @ 1,000

Gov. Speed [RPM] 1,800

Engine Type	Diesel, 4-Cycle
Configuration	Inline 6-Cylinder
Displacement	12.4 L (758 cu. in.)
Bore & Stroke	4.96 in. & 6.54 in. (126 mm & 166 mm)
Compression Ratio	18.5:1
Aspiration	Variable Geometry Turbocharger
Combustion System	Direct Injection 2500 bar HPCR
Engine Lubrication	42 Quarts (40 L)
Total Engine Weight (Dry)	2,299 lbs. (1,099 kg)
Valves	4 Valves Per Cylinder, Single Overhead Camshaft
B10 Design Life	1,200,000 mi (1,931,000 km)

### Best-In-Class Engine Warranty

Standard Engine Warranty	2 years, unlimited miles, unlimited hours
Optional Engine Warranties	Up to 6 years, 600,000 miles, unlimited hours
Optional Major Component Coverage	Up to 7 years, 700,000 miles, unlimited hours



## INDUSTRY-BEST B10 DESIGN LIFE.

The A26 is the first engine in the industry to meet rigorous B10 design life standards for an unsurpassed 1,200,000 miles.

The B10 designation is the mileage at which 10% of engines are expected to require a rebuild. Most competitors use a B50 designation where 50% of their engines are expected to require a rebuild, at 1,000,000 miles.

Only the A26 meets the B10 standard for 1,200,000 miles. If your trucks are averaging 60,000 miles each year, that's the equivalent of running over 3 more years before your first major overhaul - real savings that impact your business.



ACHIEVING B10 DESIGN LIFE STANDARDS. International B10 standards require 90% of all engines to endure 1.2 million miles before a rebuild is required.

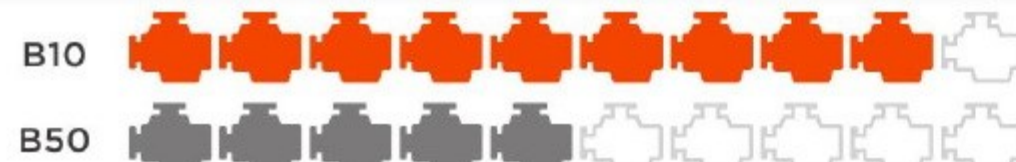

**Pistons** are engineered with a low-friction skirt coating and advanced piston ring geometry to reduce parasitic losses and enhance fuel economy.



The **single stage EGR cooler** is constructed of laser-welded stainless steel to deliver proven reliability and performance in a compact, easy-to-service design.



**Gear teeth** are produced using an innovative grinding process for smoother, harder and quieter gear surfaces.

## DURABILITY IN EVERY DETAIL.

EVERY DETAIL OF THE A26 IS ENGINEERED FOR UPTIME, AND EXTENSIVELY TESTED TO VALIDATE ITS PERFORMANCE OVER THE LONG HAUL.

### CYLINDER HEAD

The innovative A26 cylinder head achieves the perfect balance between optimal weight, strength, cooling and breathing:

- Innovative gray iron material offers the high strength and thermal conductivity needed for advanced breathing and cooling
- Extensive computer modeling and analysis optimizes port flow geometry to substantially reduce air restriction, helping the engine breathe more consistently from cylinder to cylinder for increased fuel efficiency
- Water jacket geometry ensures that more coolant flows to the hottest areas of the cylinder head that need it most, with less restrictive flow that reduces parasitic loss to the water pump for improved fuel economy



Free breathing intake port geometry

Lower water jacket cools the flame deck first

Better flow achieved through the exhaust ports

## TESTED AND VALIDATED TO NEW INDUSTRY STANDARDS.

International engineers pushed the A26 far beyond industry testing norms, including hundreds of thousands of hours of dynamometer testing. We performed more "key life" tests than we ever have before, testing each component to the end of its life. And we put the A26 through its paces over millions of real-world miles. Through every test, the A26 delivered uncompromising new standards of durability.

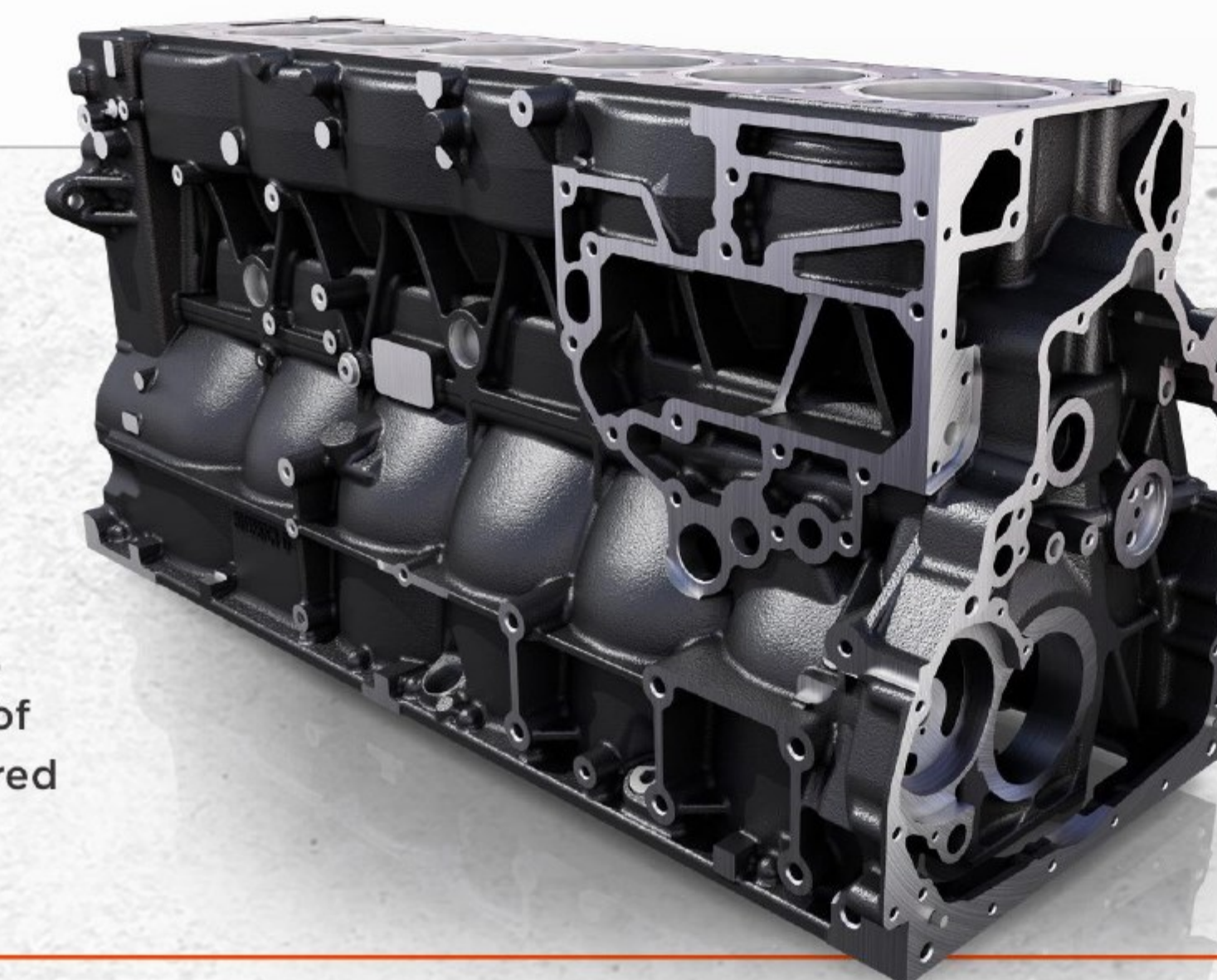

The **crankcase** is constructed with North America's first big bore Compacted Graphite Iron (CGI) design for 75% higher tensile strength and 45% greater stiffness while reducing weight, noise and vibration.



### SHEDDING POUNDS TO BOOST PRODUCTIVITY.

Here are just some of ways that the RH Series is engineered to significantly reduce weight and improve efficiency without compromising strength and durability.

#### Single Canister After-Treatment Device

The single canister design is smaller, simpler, lighter and easier to service than the twin-canister design used in the 2018 ProStar 113

# -105 lbs

#### International Ride Optimized Suspension (IROS)

The smooth ride on the RH Series also reduces weight over the previous generation ProStar thanks to increased use of strong, lightweight aluminum suspension components

# -128 lbs



#### A26 Engine

The CGI crankcase and other key components are constructed of advanced lightweight materials to reduce weight without compromising durability, resulting in a 55-lb weight savings over the previous N13 engine

# -55 lbs

#### Aluminum Fuel Tank Hangers

Lightweight aluminum is used for the mounting hardware on the fuel tank to shed unwanted weight from the previous ProStar design

# -53 lbs

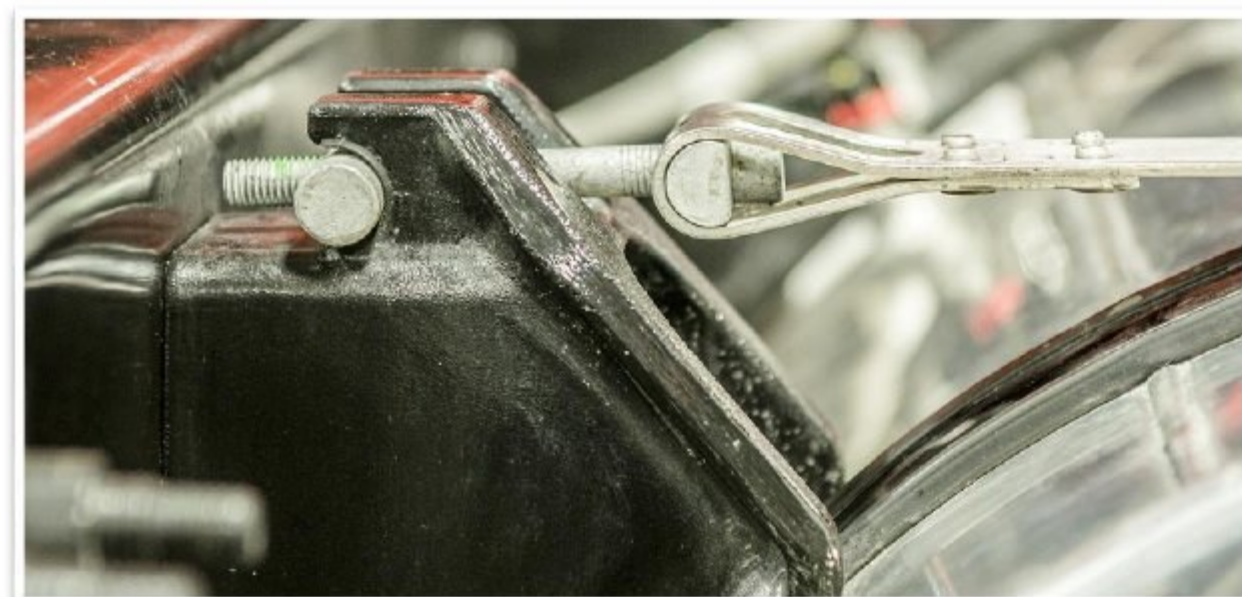

# EFFICIENT BY ANY MEASURE.

### The RH Series Day Cab with A26 Engine is up to 5.2% more fuel efficient.\*

The A26 engine produces impressive fuel efficiency gains of up to 5%, with innovative technology that squeezes optimal performance from every ounce of fuel. Additional fuel efficiency gains of up to 1% come from improved aerodynamics and drivetrain efficiencies.



# 5.2% More Fuel Efficient

■ Enhanced Aerodynamics: 2.5%    ■ International(R) A26 Predictive Cruise Control Enhancements: 2%

■ Flow Below 2.0+ vs. Flow Below 1.0: 0.7%

80,000 miles/year @ 7.42 miles / Gallon = 10,782 gallons/year

5.2% = 7.81 miles/gallon = 10,249 gallons/year

**Saves 533 gallons/year**

**Multiplied across a 40 truck fleet could yield over 35,000 gallons of fuel saved per year**

\* When compared to the introduction of the 2020 model year.



### DAY CAB

113" BBC

Local, Regional, Bulk and Specialized Applications



### 56" LOW ROOF SLEEPER

113" BBC

Regional Line Haul, Bulk, Flatbed and Specialized Applications



### 56" HI-RISE SLEEPER

113" BBC

Local to Regional-Haul and Specialized Application

#### GVW

- ▶ 32,000 – 60,000 lbs.

#### BBC/BA

- ▶ 125"/ 50"

#### Cab Configurations

- ▶ Day Cab
- ▶ 56" Low Roof Sleeper
- ▶ 56" Hi-Rise Sleeper

#### Wheelbase Options

- ▶ 146 - 226" 4x2
- ▶ 152 - 240" 6x4

#### Axle Configurations

- ▶ 4x2, 6x2, 6x4

#### Rear Axle

- ▶ SINGLE REAR AXLE (4x2)
  - Meritor: 23,000 lbs.
  - Dana Spicer: 23,000 lbs.
- ▶ TANDEM REAR AXLE (6x4)
  - Meritor: 40,000 – 46,000 lbs.
  - Dana Spicer: 40,000 – 46,000 lbs.

#### Front Axle

- Hendrickson: 12,000 – 14,000 lbs.
- Dana Spicer: 12,000 – 14,000 lbs.
- Meritor: 12,000 – 14,000 lbs.

#### Frames

- ▶ Heat Treated Alloy Steel 120,000 PSI

#### Front Suspension

- ▶ Spring Monoleaf: 12,000 – 13,200 lbs.
- ▶ Parabolic Taperleaf: 12,000 – 14,000 lbs.

#### Rear Suspension

- ▶ AIR SINGLE
  - International: 20,000 lbs.
  - International: 23,500 lbs. Vari-rate spring
- ▶ AIR TANDEM
  - International: 40,000 lbs.
  - Hendrickson: HTB 40,000 lbs.
  - Hendrickson: HAS 40,000 – 46,000 lbs.

#### Brakes

- ▶ Air Drum Brakes with ABS with Optional Automatic Traction Control and Electronic Stability Control
- ▶ Air Disc Brakes with Automatic Traction Control, and Electronic Stability Control

#### Power Steering

- ▶ Sheppard
- ▶ TRW

#### Engines

- ▶ International® A26: 365 – 475 hp and 1,250 – 1,750 lb.-ft.

#### Transmissions

- ▶ Automated Manual Transmissions
  - Eaton Endurant: 11, 12 speed
  - Eaton Fuller UltraShift PLUS: 13, 18 speed
  - Eaton Fuller Advantage: 10 speed
- ▶ Manual Transmissions
  - Eaton Fuller Advantage: 10 speed
  - Fuller: 10, 13, 18 speed
- ▶ Automatic Transmissions
  - Allison 3000: 6 speed



# AVAILABLE CONFIGURATIONS.



### SLEEPER FEATURES

12 Volt Power Supply
Trim Panels
Headliner
Sleeper Windows
Windshield Curtain
Sleeper Control Panel
Microwave Accommodation
TV Accommodation

### 56" Low Roof Sleeper Features

Overhead Storage
------------------

### 56" Hi-Rise Sleeper Features

Overhead Storage
Rear Wall Storage

### CLASSIC

Standard
Easy to Clean Soft Vinyl Neutral Trim Panels
Soft Vinyl
Standard
Optional
Standard
Optional
Optional

Two Airline Style Cabinets standard, with an Option for Two Additional
--

Two or Four Compartments with Netting or Doors
Optional

### DIAMOND

Standard
Easy to Clean Soft Vinyl Trim Neutral or Available Black Cherry Accents with Woodgrain Inserts
Soft Vinyl
Standard
Optional
Standard
Optional
Optional

Two Airline Style Cabinets Standard, with an Option for Two Additional
--

Two or Four Compartments with Netting or Doors
Optional

### CAB FEATURES

Cab Trim Panels
Door Trim
Trim Inserts
Instrument Panel
Gauge Cluster
Accent Color
Sun Visors
Lighting
Window Controls
Lock Controls
Cup / Bottle Holders
Overhead Console
USB Accessory Port

### CLASSIC

Easy to Clean Soft Touch Vinyl
Easy to Clean Soft Touch Vinyl
Neutral
Black
Premium 8-Gauge, 5" Color Display with Virtual Gauges Optional: 8-gauge, 3.5" Display with Odometer and Trip
Neutral
Two
LED
Manual or Power
Manual or Power
Four
Molded Plastic with Retainer Nets and CB Radio Housing and Paper Towel Storage in Sleeper Configuration
Up to 4

### DIAMOND

Easy to Clean Soft Touch Vinyl
Available with Black Cherry Accents - Padded Gray or Black Cherry Soft Touch Panels
Woodgrain - Optional Black Cherry Door Toppers
Black
Premium 8-Gauge, 5" Color Display with Virtual Gauges Optional: 8-gauge, 3.5" Display with Odometer and Trip
Neutral - Optional Black Cherry
Two
LED
Power
Power
Four
Molded Plastic with Retainer Nets and CB Radio Housing and Paper Towel Storage in Sleeper Configuration
Up to 4

## REMOTE DIAGNOSTICS FOR ALL MAKES OF VEHICLES.

All RH models come equipped with OnCommand Connection telematics and a free two-year subscription to our Advanced Remote Diagnostics solution.



## ALL THE TOOLS YOU NEED AT YOUR FINGERTIPS

OnCommand<sup>®</sup> Connection is designed to keep your vehicles moving and your profits rising through powerful features such as **interactive mapping**, **engineer-designed action plans** and **access to your fleet health information** through our portal or customized reporting to your email inbox

### OnCommand<sup>®</sup> Connection Features:



#### Customizable Dashboard

Easily track vehicle location data, vehicle health status, and more to stay fully informed on your fleet



#### Live Fault Code Action Plans (FCAPs)

Simple fault code descriptions, rating of fault severities and recommended actions to address the issue to help you prioritize which vehicles need repairs and keep your fleet running at peak performance



#### Vehicle Health Reports

Detailed history and health information on every vehicle, including fault code history, engine status, fluid levels and more



#### Geofencing

Set up designated areas and generate reports on which vehicles are inside and outside of those areas

## A REVOLUTION IN FLEET SERVICE MANAGEMENT

International<sup>®</sup> 360, a ground-breaking service communication and fleet management platform that can help you manage your entire portfolio of assets with ease while enabling streamlined, transparent communication with dealerships and more efficient fleet operations.

### BOOSTING UPTIME AND LOWERING TOTAL COST OF OWNERSHIP.

International 360 is built to transform your service process and revolutionize how you manage the utilization of your assets:

- ▶ Seamless communications with dealers and up-to-date repair status visibility
- ▶ Complete VIN-based information – asset specs, complete parts catalog, available service information, even remote diagnostics and health data
- ▶ Instant online service request initiation and estimate approvals
- ▶ Complete service history, up-to-date campaign information, and engine calibration status

# INTERNATIONAL<sup>®</sup> 360

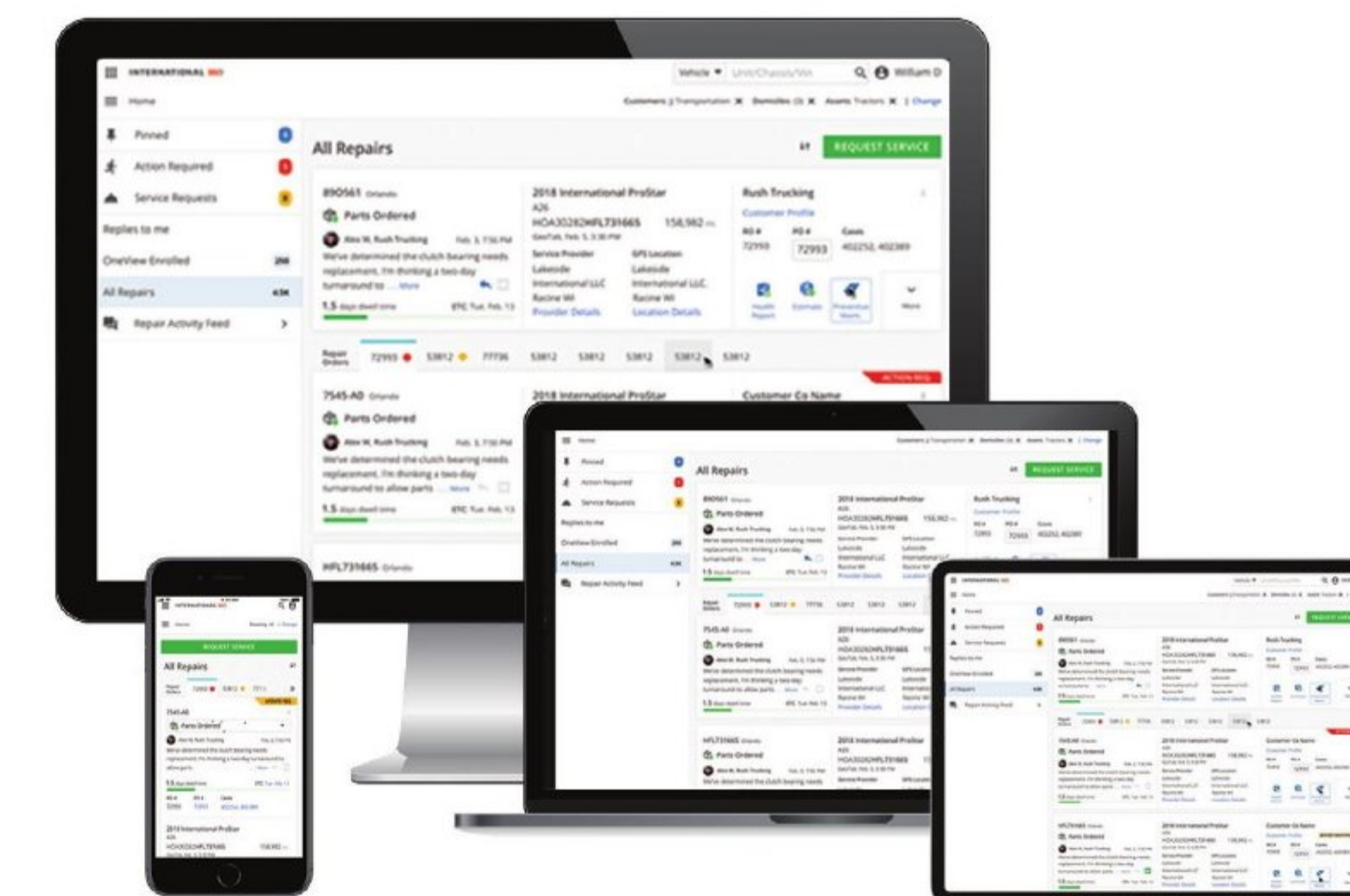



## WE HAVE YOUR BACK SO YOU CAN KEEP MOVING FORWARD

Your International dealer is one of the best in the business, and a strong link in the industry's broadest, most capable parts distribution and dealer network.



### DIAMOND EDGE<sup>SM</sup> CERTIFIED INTERNATIONAL TRUCK DEALERS

This select network of International dealer service departments has passed rigorous parts and service certification guidelines to provide you with faster turnarounds, immediate parts availability and a higher level of servicing expertise. Their ongoing pledge is to maximize your uptime and deliver a best-in-class customer experience.

### LESS LOST DAYS. MORE OPEN BAYS.

We've also increased your access to more service locations with our Love's & Speedco partnership. Over 300 locations are International Truck Certified Service Partners, factory-trained and authorized to perform warranty work for International Truck Class 6 through 8 trucks to get you back on the road quickly, maximizing uptime.\*



So no matter where you drive, you're not far from one of our

# 1,055

## DEALER LOCATIONS

Leading all competitors in

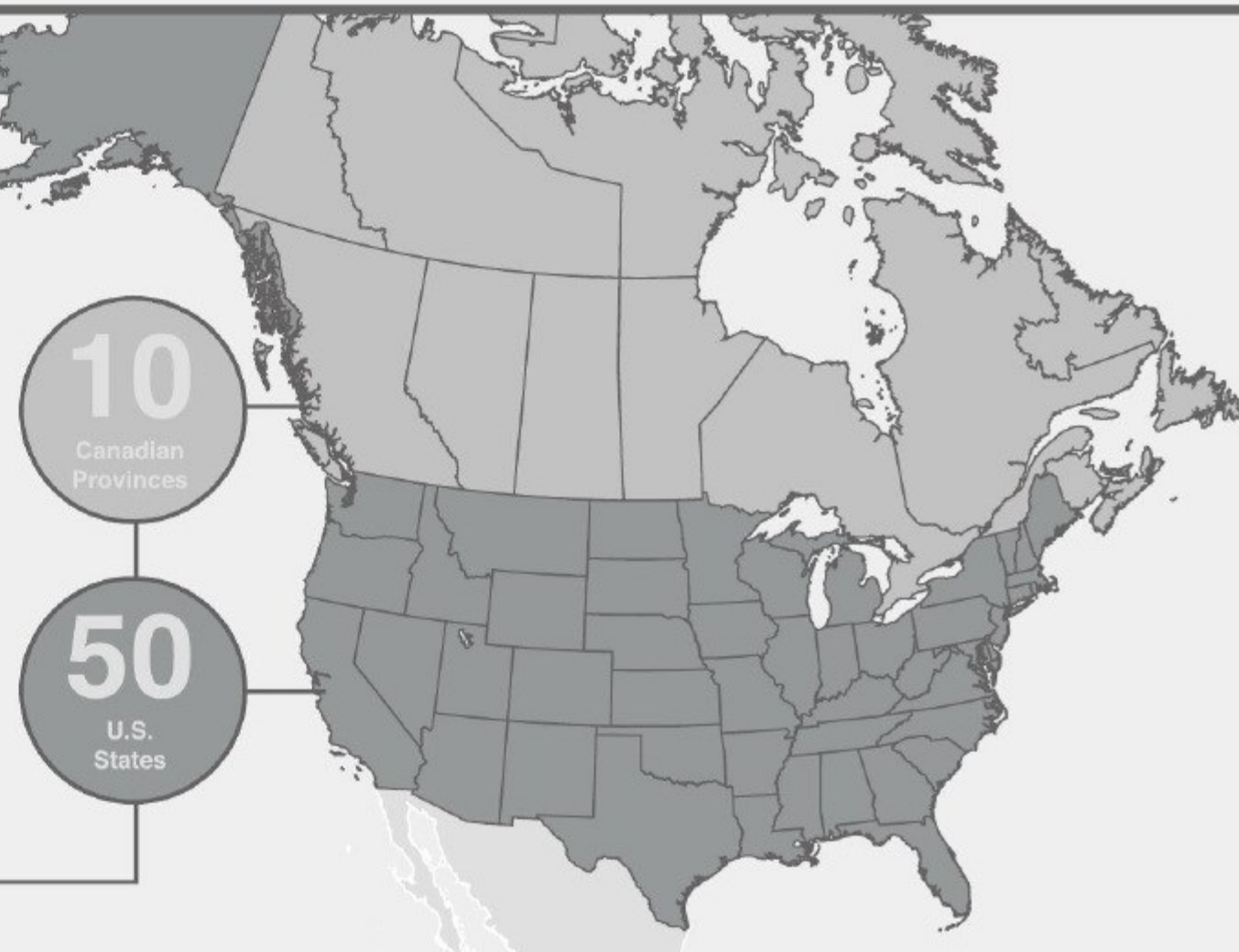

## 10,786+

TECHNICIANS

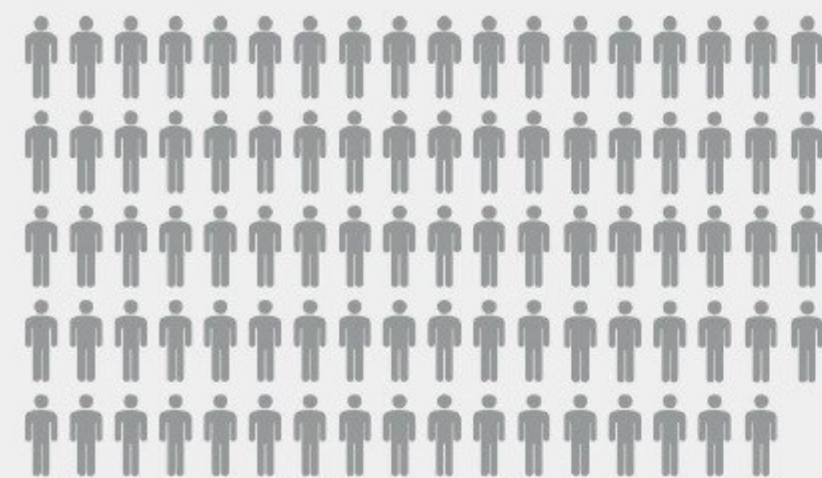

## 8,625+

SERVICE BAYS

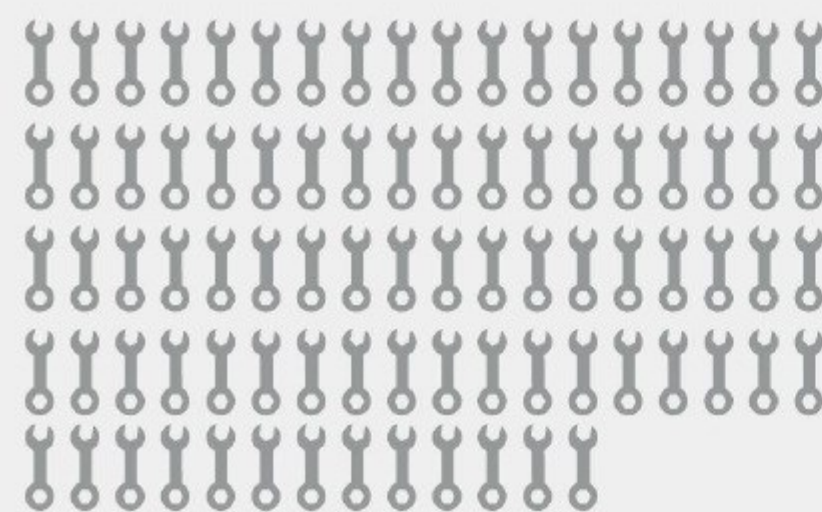

## NAVISTAR<sup>®</sup> CAPITAL

a BMO Financial Group program

Navistar Capital is an industry leader in commercial vehicle financing with over 40 years of experience. We provide customized leases and secured loans with flexible structuring for International heavy and medium duty commercial vehicles. Contact your local International Truck dealer for more information.



Fleetrite is the first name recognized for trusted quality in aftermarket truck and bus parts. With 50 years of strong performance in the industry, Fleetrite parts are OEM aftermarket quality approved and are backed by a one-year nationwide parts and labor warranty. High-quality parts at a competitive price. It's the reason why it's always the first recommended by more than 700 International Truck and IC Bus dealers. Your uptime is our first priority. Ask for Fleetrite First.

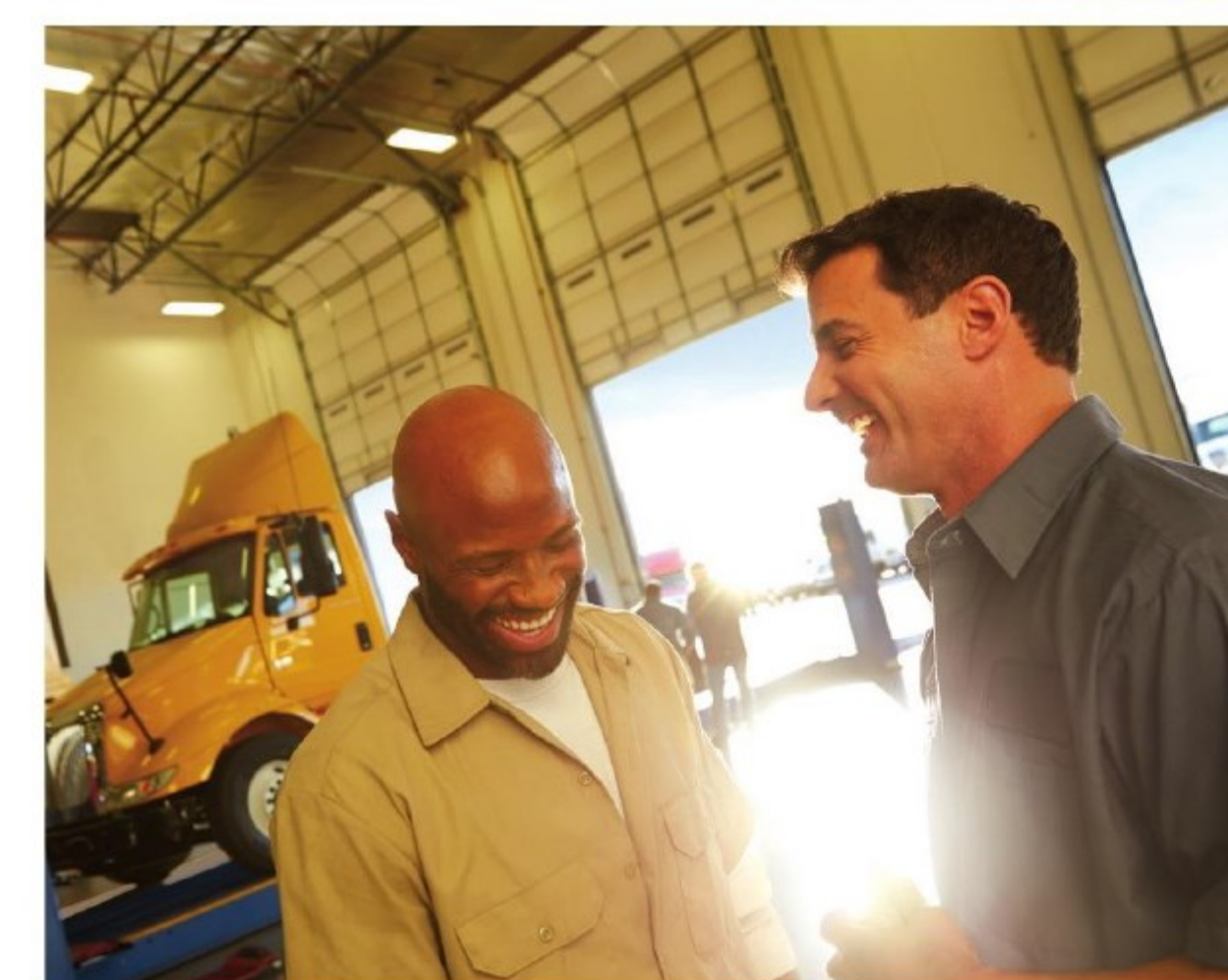

# TOP OF THE LINE. TOP OF MIND.



\*Love's and Speedco locations in Texas cannot perform warranty services.



**THE RH SERIES IS POWERED BY THE INTERNATIONAL A26,  
BUILT WITH UPTIME IN ITS DNA.**



**Note:** The information and conclusions contained herein are believed to be correct at time of publication, but do not necessarily apply to similar vehicles with different specifications or with production dates after the production of this publication. Vehicles with different specifications or later dates of production may yield different results. Vehicle specifications are subject to change without notice. TAD17012 10/2019 ©2019 NAVISTAR Inc. All rights reserved. All marks are trademarks of their respective owners.