

1988 Montero

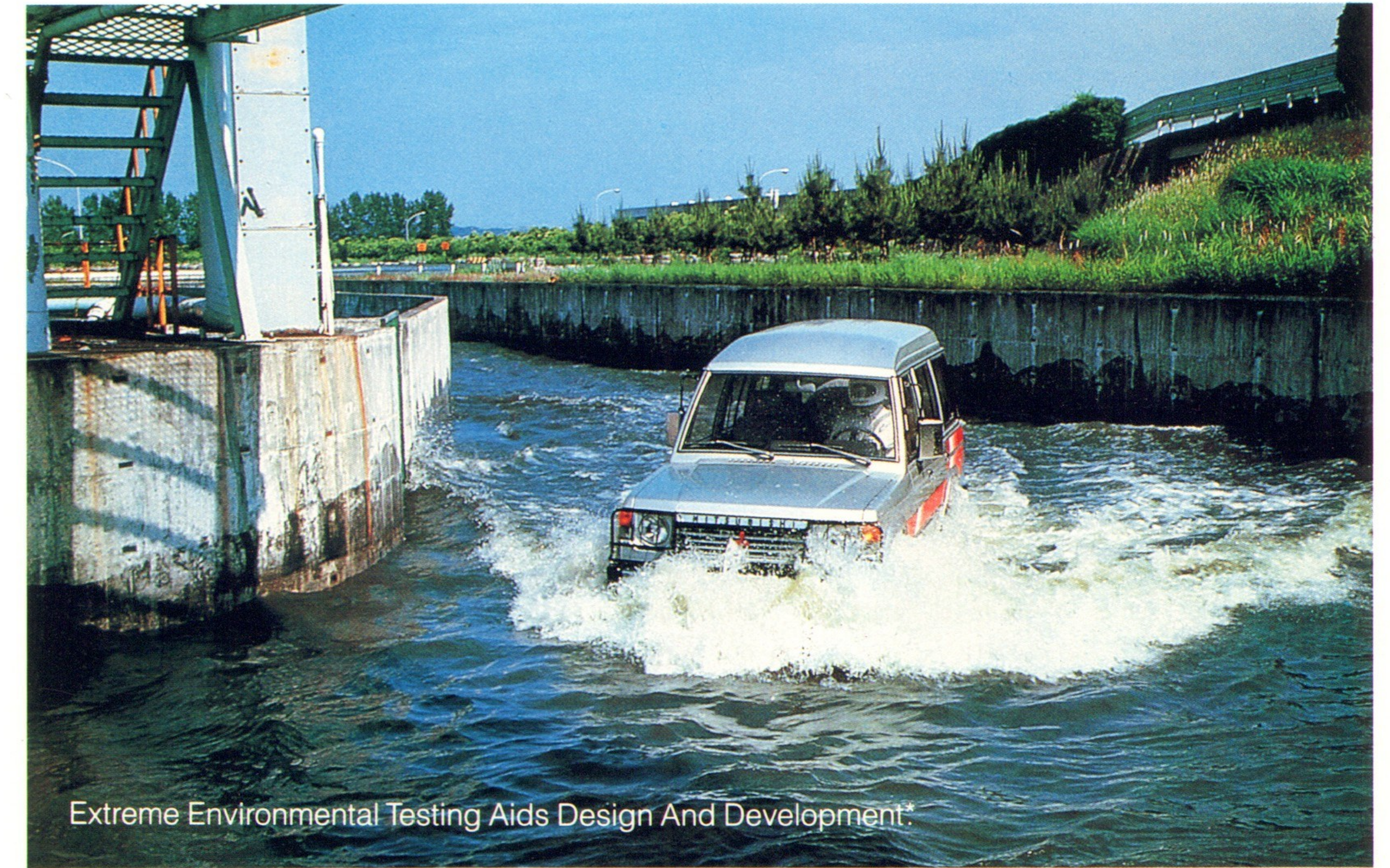

M I T S U B I S H I



Extreme Environmental Testing Aids Design And Development.

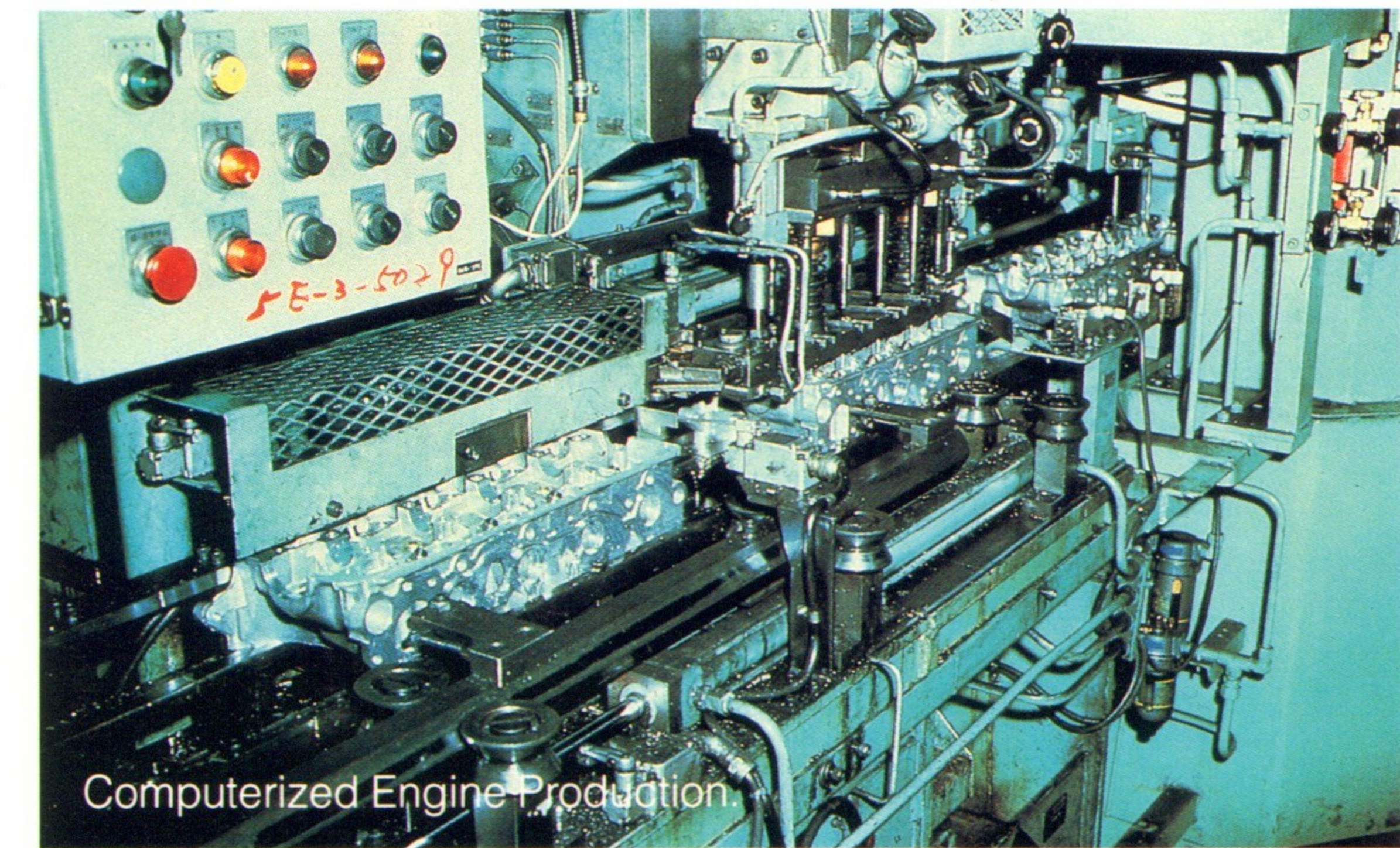

Computerized Engine Production

Mitsubishi Motors... Our Experience Shows.

In the last seventy years, Mitsubishi Motors Corporation has become one of the world's largest manufacturers of cars and trucks, producing over 1.2 million vehicles last year alone.

In 1988, the quality vehicles that carry the Mitsubishi name are the result of years of experience, research and technological refinement. All combined to provide you with a vehicle that is not only reliable, stylish and efficient, but one that truly performs.

There's Always a Better Way.

Mitsubishi has long been recognized throughout the industry for its leadership in engineering advancements that improve and enhance the performance and durability of its vehicles. Some of its many achievements include aerodynamic flush body styling for improved efficiency and patented Dual Engine Stabilizers,[™] an internal counter-balancing system used in most of its 4-cylinder powerplants to neutralize inherent vibra-

tions for quieter, smoother engine operation.

Mitsubishi sets the standard in the manufacture of rugged four-wheel drive vehicles. The use of skid plates at vital undercarriage points, a tough six cross-member ladder frame and independent front suspension ensure that Mitsubishi four-wheel drive vehicles perform equally well on-road or off.

Mitsubishi is continuing its commitment to the research and development of

components, integrated control systems and aerodynamic exterior and ergonomic interior design to develop cars, trucks, and sport utility vehicles to meet the needs of the future.

Mitsubishi Montero. The Great Way to Get There.

Whether it's a smooth ribbon of pavement, a dusty trail, knee-deep mud or swollen rivers, the Mitsubishi Montero gets you there in style. Its rugged con-

struction can take on a variety of road conditions with ease, plowing through the backwoods as easily as cruising the highways. The hefty 2.6-liter 109-horsepower engine has the heart to take on the tough terrain, while the fully independent front suspension with unequal-length A-arms, torsion bars, telescopic shock absorbers, stabilizer bar and power-assist vented disc brakes give you a sure feel for the road and a comfortable ride.

The interior offers an exceptional

degree of comfort, including reclining low back velour front bucket seats with adjustable headrests, height adjustable steering column with sport steering wheel, remote locking rear door and full instrumentation including inclinometer.

Take a few minutes to fully review the many features offered on the Mitsubishi Montero. If you're looking for a rugged sport utility vehicle that's at home just about anywhere, you'll see why Mitsubishi is the obvious choice.

*Not recommended driving for vehicle.

M O N T E R O S P O R T



**When the Road Ends,
the Fun Begins.**

All you need to fully appreciate the Montero Sport's multi-purpose utility is an adventurous spirit and a tough stretch of outback. This vehicle was built with the guts to go just about anywhere, and do it in style and comfort.

Montero Sport begins with the rock steady foundation of a six crossmember ladder frame, mated to a solid steel body. Drop in a rugged and proven 2.6-liter SOHC 109 hp engine. Temper it with a fully independent front suspension,

and finally, add a limited slip differential for exceptional traction in snow, sand or mud. And there you have the blueprint for one of the toughest off-road performers yet conceived.

Montero Sport's sophisticated suspension and "shift-on-the-fly" drivetrain are

protected with full skid plate armor at the gas tank, engine and transmission/transfer case. And with the front differential mounted directly to the frame, you'll get a full 9.1" of front end ground clearance.

But no matter how far you wander, Montero Sport never loses its sense of style and sophistication. After all, getting away from it all shouldn't mean you can't take a little civilization with you.



Versatile Utility in a Sporty Package.

From its distinctive, rugged styling with sporty accent stripe to its stylish spoked wheels, the Montero SP is a true sport utility vehicle through and through. Its off-road 4WD capability, powered by a 2.6-liter, 109-hp, SOHC engine will

bring out the sport in you on smooth pavement or rough backroads. And when there's work to be done, the Montero SP takes its utilitarian role seriously. With 62.9 cubic feet of cargo space in the rear, Montero SP is at home at work as it is at play. Its rugged inde-

pendent front suspension can handle loads of luggage or the tools of your trade comfortably. If you plan to carry more passengers and less cargo, a fold-down rear bench seat is available as a dealer installed option. Either way, the cargo area is completely carpeted for added

convenience, cargo protection, and sound insulation. When you need a vehicle that takes work as seriously as you take having fun, Montero SP is the one that combines sport and utility into one versatile on- and off-road machine.

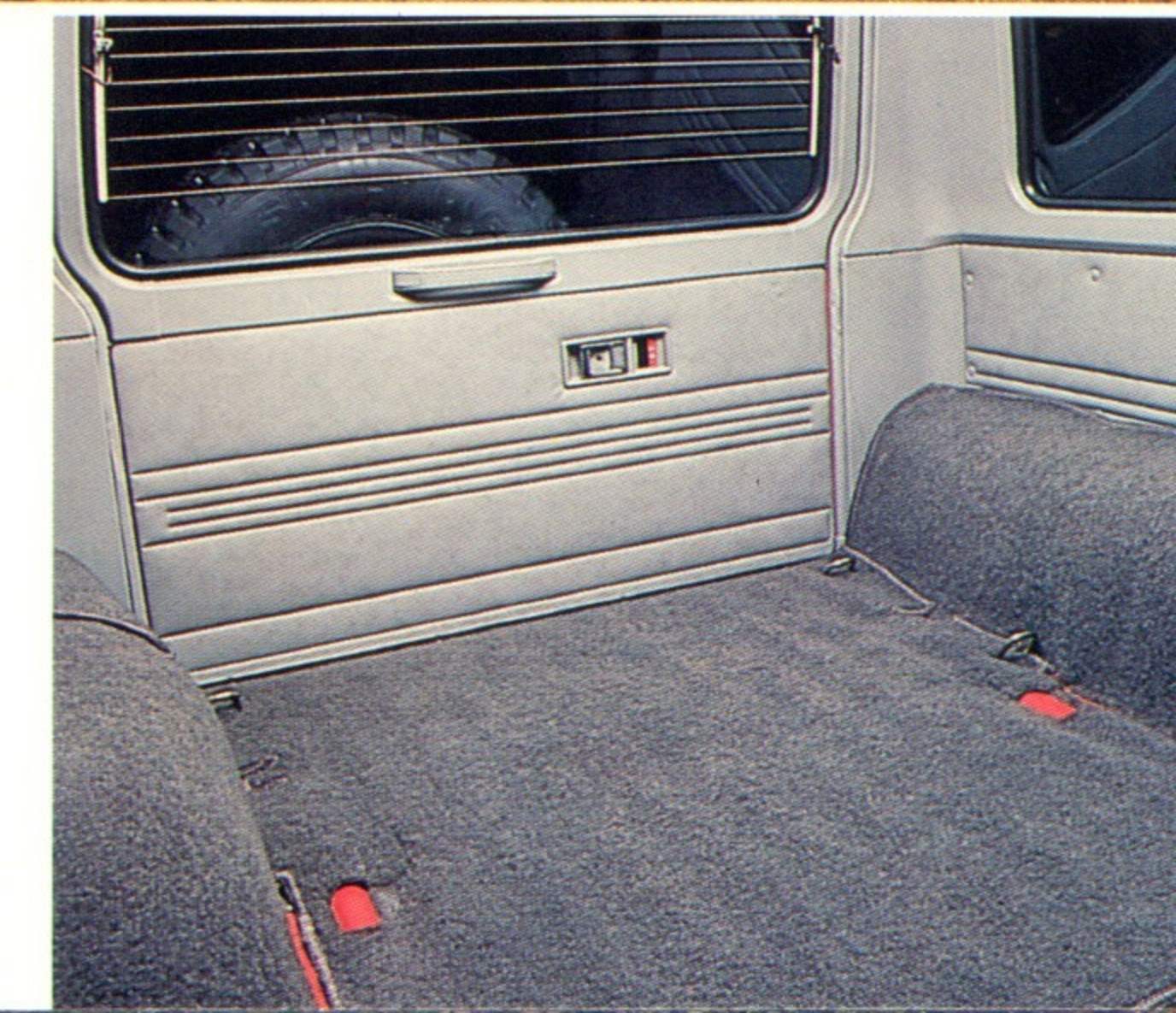



The Commanding View.

From inside Montero, the view outside is clear and unobstructed. You're surrounded by nearly 360 degrees of tinted glass. Now drop your eyes to the instrument panel. It's a complete guidance system with at-a-glance analog instrumentation and easy access controls.

Front and center, there's a speedometer, tachometer, fuel and temperature gauges, plus indicator lights for monitoring Montero's vital functions. High and to the right rests an instrument cluster for a voltmeter, oil pressure gauge and inclinometer, which graphically shows the angle of the terrain you're rolling over.

Behind the padded sports steering wheel, there are dual stalk mounted controls to adjust the intermittent wiper/washer, headlamps and turn signals. All within easy reach.

Year round comfort is yours with a dual bi-level heat/ventilation system and optional air conditioning. And to stir your soul, Montero Sport offers the incredible sound of a four speaker, electronically tuned AM/FM stereo radio with cassette deck, or choose the optional electronically tuned AM stereo/FM stereo cassette with graphic equalizer and four speakers. The Montero SP makes music your option with either an electronically tuned AM/FM stereo radio or an electronically tuned AM/FM stereo radio with cassette deck—both with four speakers.



Driver's Suspension Seat.



Rear Bench Seat.

It's all there and more. From the convenience of remote releases for the fuel-filler door and rear swing-away door to the height adjustable steering column for greater driving comfort. Montero's interior was obviously designed with your comfort and convenience in mind.

For an extra measure of versatility, the Montero Sport comes standard with a rear bench seat that folds forward to provide additional useful cargo space. The rear bench seat is available as a dealer installed option on the Montero SP, which comes standard with 62.9 cubic feet of carpeted cargo space. Whichever you choose, go ahead and rough it in high style.



Get to the Rough Without Getting Roughed Up.

Inside Montero Sport and SP is an invitingly comfortable interior that is truly civilized and spacious. There's luxurious velour upholstery covering a pair of comfortable and supportive reclining, low-back bucket seats with adjustable headrests. Underfoot is plush carpeting designed to wear like iron and look great all the time.

Montero Sport features a driver's seat fitted with adjustable suspension damp-

ing, to further enhance ride quality down long stretches of rough road.

Both Montero Sport and SP offer the convenience of automatic locking front hubs that allow you to make the change from 2WD to 4WD without leaving the driver's seat. So go where you want to go. Across town or across the Mojave, you'll find that the best part of the trip is getting there.

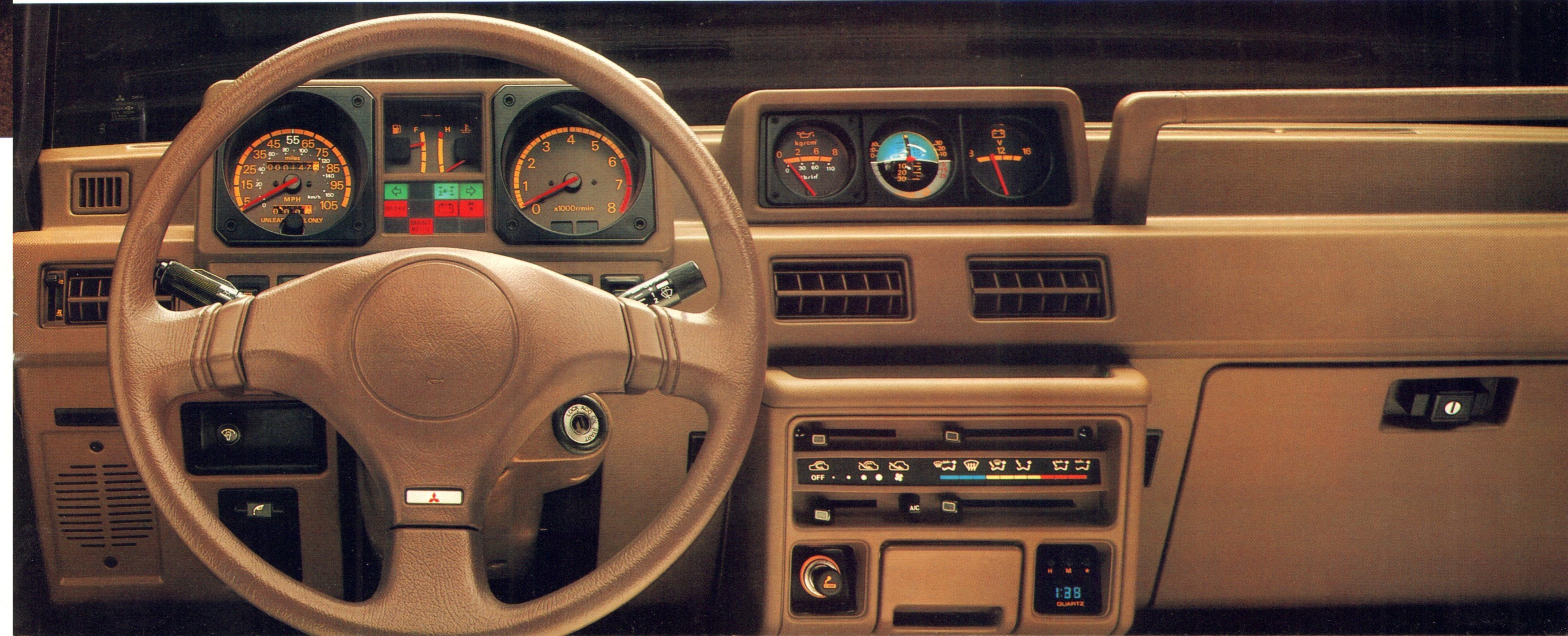

Unequaled from the Streets of Paris to the Sands of the Sahara.

The Paris-Dakar Rally. Nothing comes close to putting a vehicle through more extremes than this ultimate off-road race. Where else will you find an 8,500 mile crash course across the scorching Sahara desert, through monsoon swollen rivers and roads with knee-deep mud?

Worse, the race goes on for days, even weeks at a time, with only one thing that's certain—far fewer vehicles will make it across the finish line than the starting line of the Paris-Dakar Rally.

This is the environment that the Mitsubishi Montero thrives in. For five years running, Montero (called "Pajero" in Europe) has won a Marathon Class—the class which absolutely forbids changing or replacing any major part during the race.

No one else has ever won five times in a row. Not Porsche, Peugeot, Volvo, Mercedes or Toyota—no one but Mitsubishi. And in 1987, Montero went



one better, taking first place in the Team Performance Class.

Nothing tells the story of Montero's rugged durability like its impressive list of wins and finishes during the last five Paris-Dakar Rallies.

Montero Pajero Paris-Dakar Rally Wins.

- 1983: Marathon Class (No replacement of Major Parts): 1st, 2nd, 5th
Category II (Unmodified 4WD Production Vehicles): 1st, 2nd, 5th
- 1984: Marathon Class—1st.
Category II—1st, 3rd
Category IV Marathon (Modified Production Vehicles)—1st, 2nd
- 1985: Overall Winners—1st, 2nd
Marathon Class—1st, 2nd
Category II—1st, 2nd, 3rd
Category IV Marathon—1st, 2nd
Category IV-II (Modified 4WD Production Vehicles)—1st
- 1986: Overall Winners—3rd, 5th, 7th
Marathon Class—1st, 3rd, 4th, 5th, 7th, 8th, 9th
- 1987: Category IV Marathon—1st
Team Performance Class—1st
Overall Winners—3rd



What Makes Montero Run.

When you run out of road, Montero's just getting started. And with automatic locking front hubs, shifting from 2WD to 4WD (high) couldn't be easier. You can do it all without leaving the comfort of the cabin thanks to the 2-speed "shift-on-the-fly" transfer case. To disengage 4WD, simply come to a stop, shift into 2WD, backup 3 feet and you're free-wheeling again. Automatic locking front hubs are standard on both Montero Sport and Montero SP, as is a 4WD indicator light and hubs engaged light.

Satisfy Your Need for Power.

All the power you need is supplied by a 2.6-liter, SOHC counter-balanced, 109-hp engine, with the torque to haul 1,033 pounds of payload up a hill or tow a one ton trailer with ease.

Little wonder. This engine is the largest inline 4-cylinder powerplant built. Mated to a slick shifting, five-speed manual overdrive gearbox, you've got one of the best combinations of dependable power and economy* available in the Sport/Utility segment.

The main reason Montero can handle such a large displacement, stout-hearted 4-cylinder powerplant is the inclusion of Mitsubishi's patented Dual Engine Stabilizers.™ This is a system of internal counter-rotating balance shafts that effectively offset and neutralize engine vibration so well that Porsche has licensed it for use in their 944 series engines.

Room to Maneuver.

You'll be happy Montero's got a full 9.1 inches of ground clearance up front when you go out in the rough. That's partly due to the fact that the front differential is bolted directly to the frame.

Rearward, there's clearance to spare with 8.3 inches at the rear differential. Combine that with big, wide P225/75R15 all-terrain radial tires, and you've got the traction and maneuverability to get to the outback with ease.

Underneath, you're protected with a full set of skid plates. So your engine, fuel tank, front end, transmission and transfer case area are kept safe and out of harm's way.

*See EPA mileage figures in specifications section.

Great Stopping Power.

Full braking power is brought to bear by power-assisted 10-inch vented disc brakes up front, and self-adjusting drums in the rear. Together, they give your Montero a total brake swept area of 323 inches of balanced stopping power.



Automatic Locking Front Hubs.

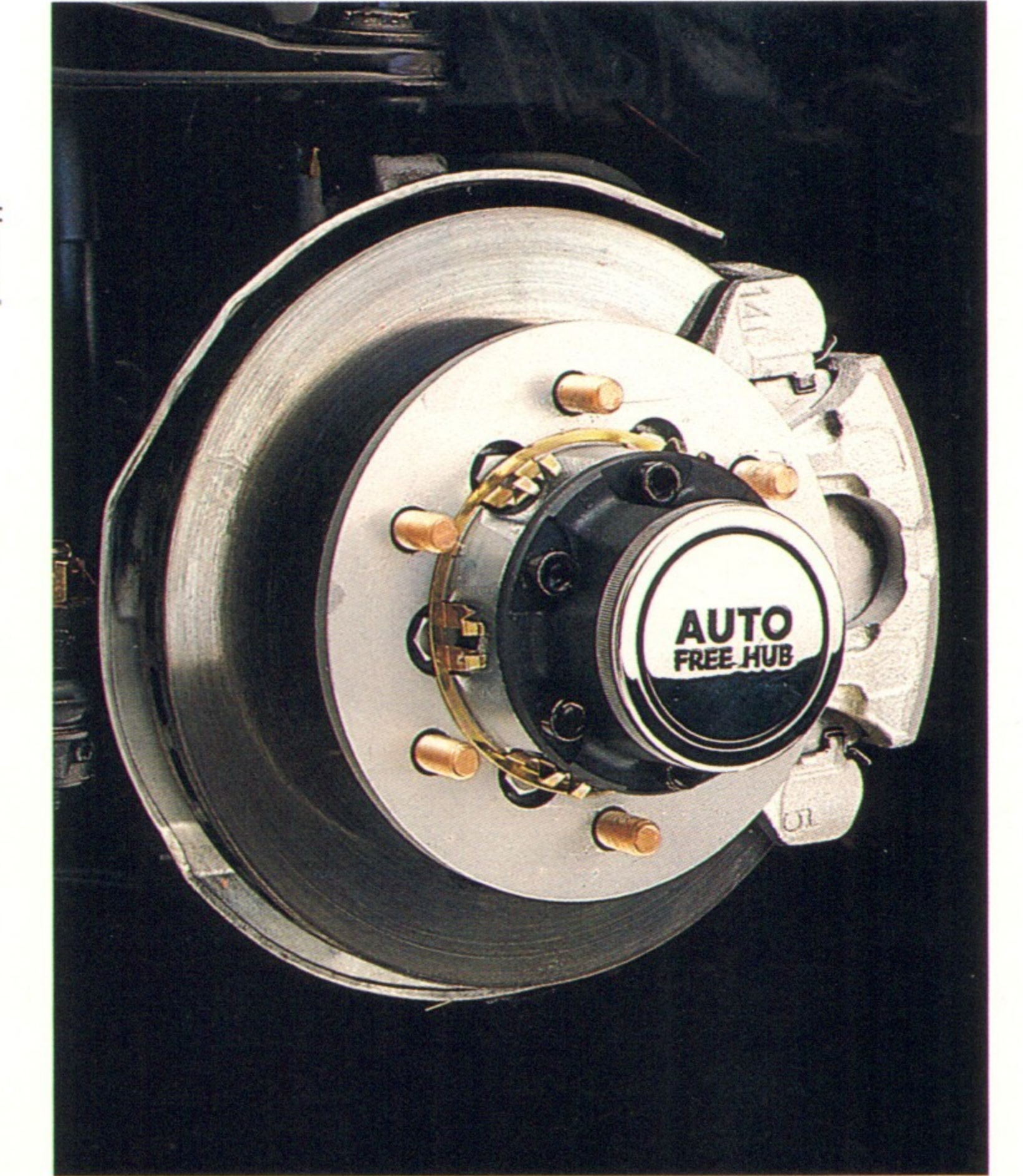

10-inch Vented Disc Brakes.

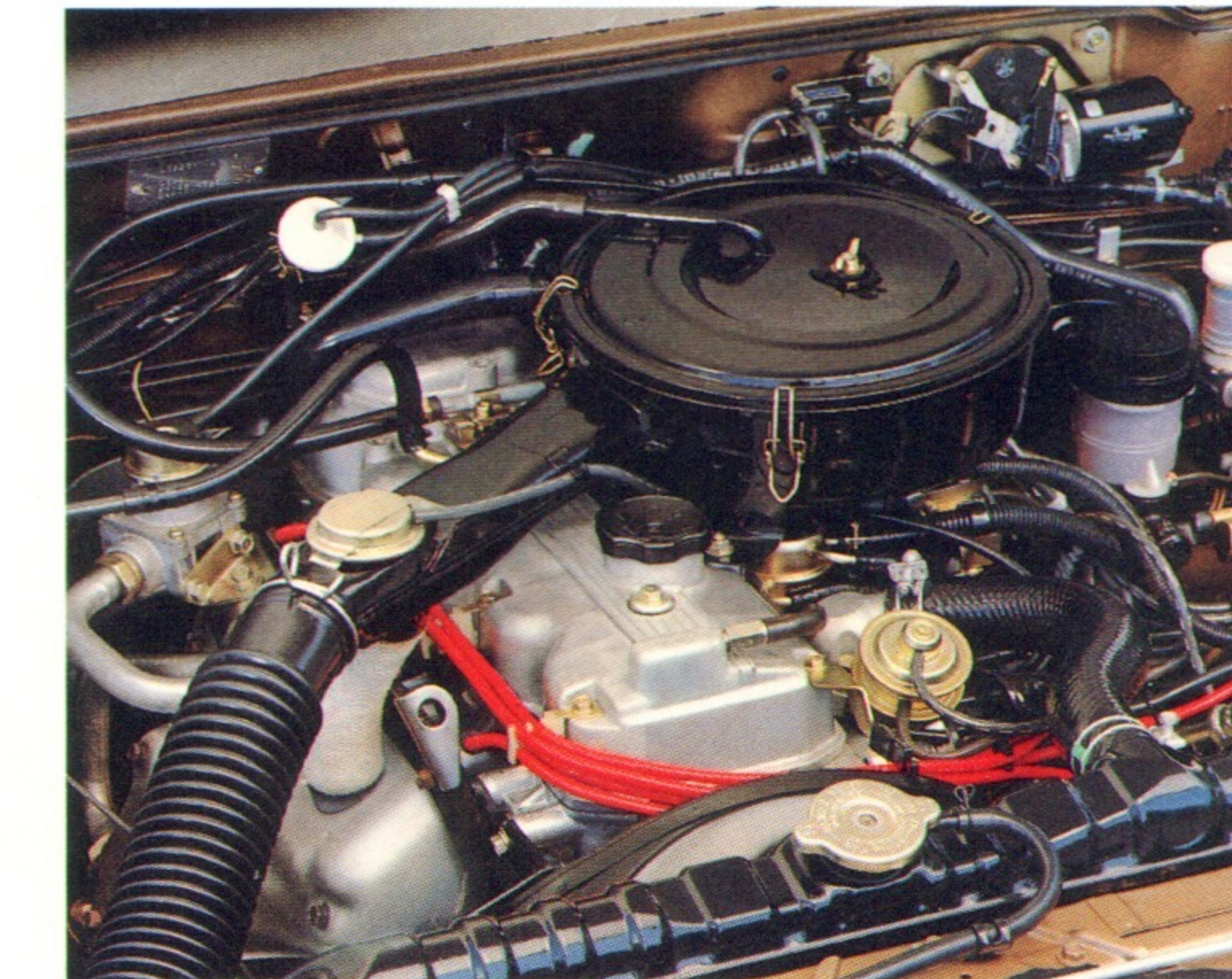

2.6-Liter SOHC Engine.



9.1 Inches Of Front Ground Clearance.

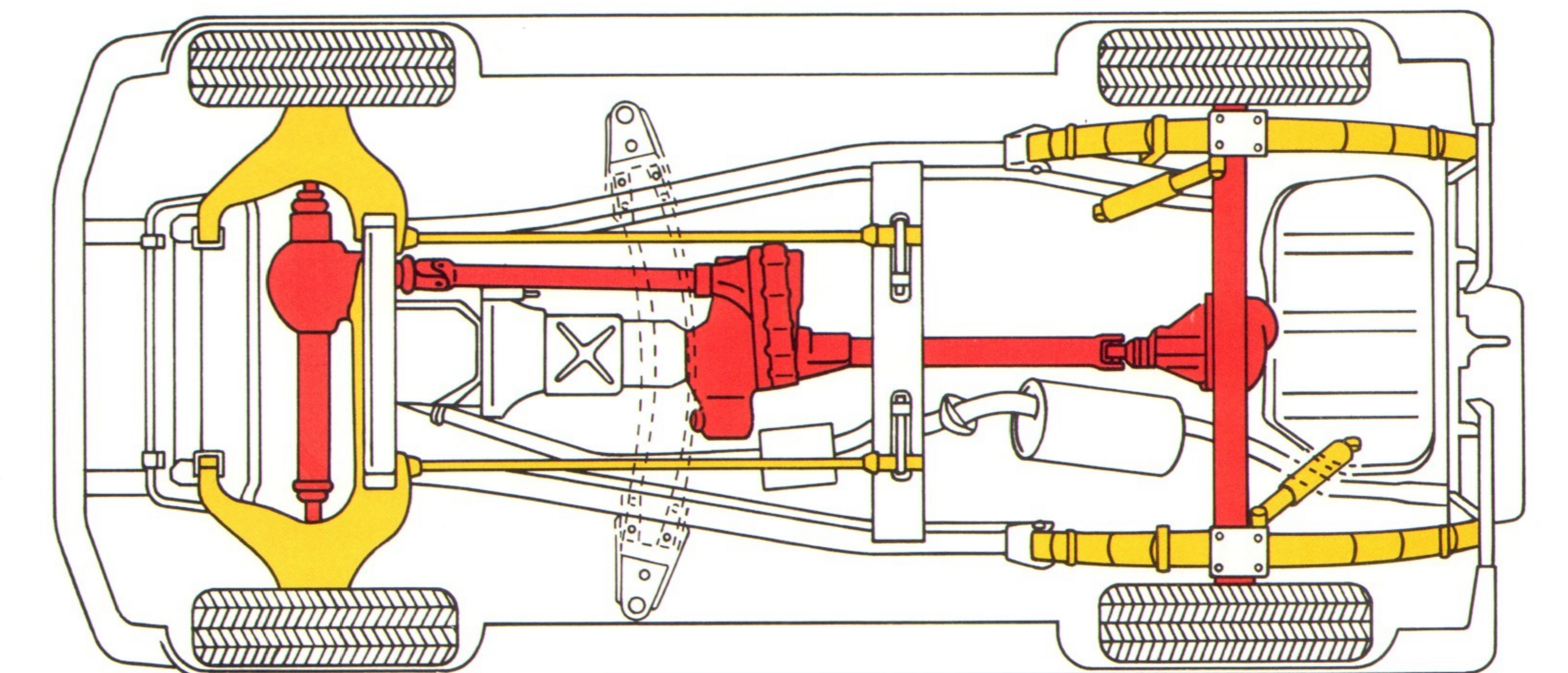

- Independent front suspension; live rear axle with leaf springs and bias-mounted shocks.
- Part-time four-wheel drive system with two-speed transfer case.

M O N T E R O O F F E A T U R E S

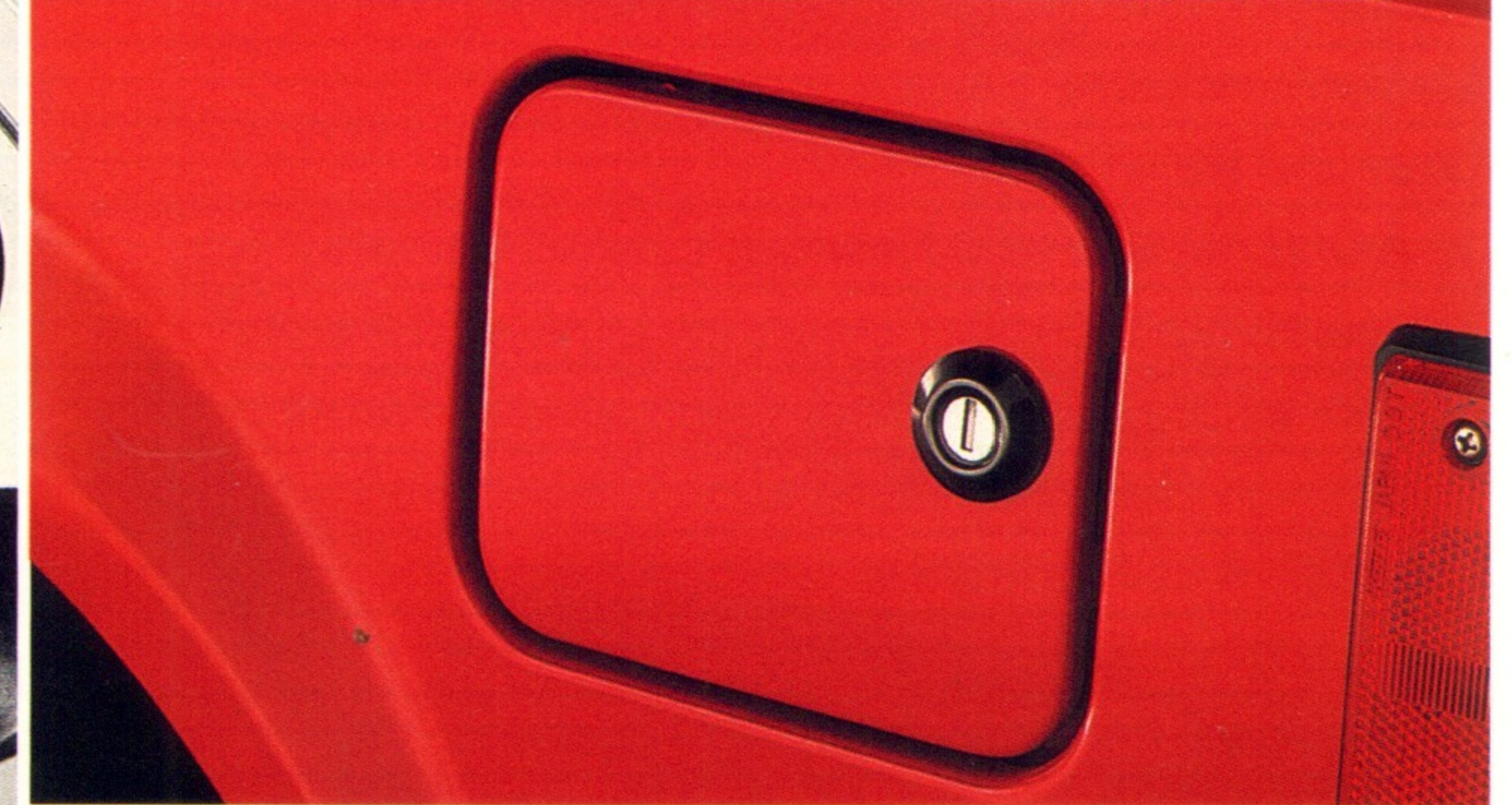
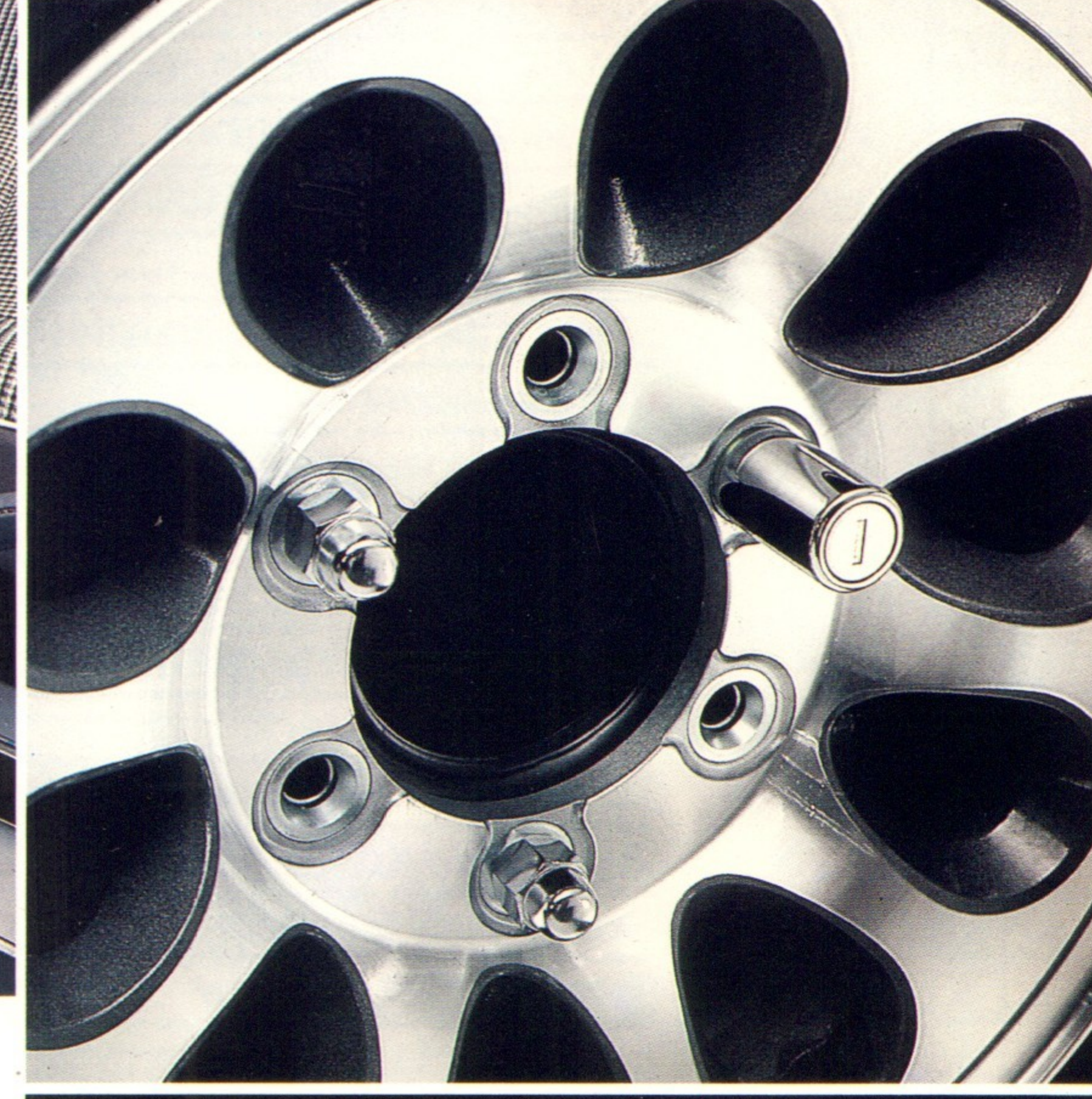
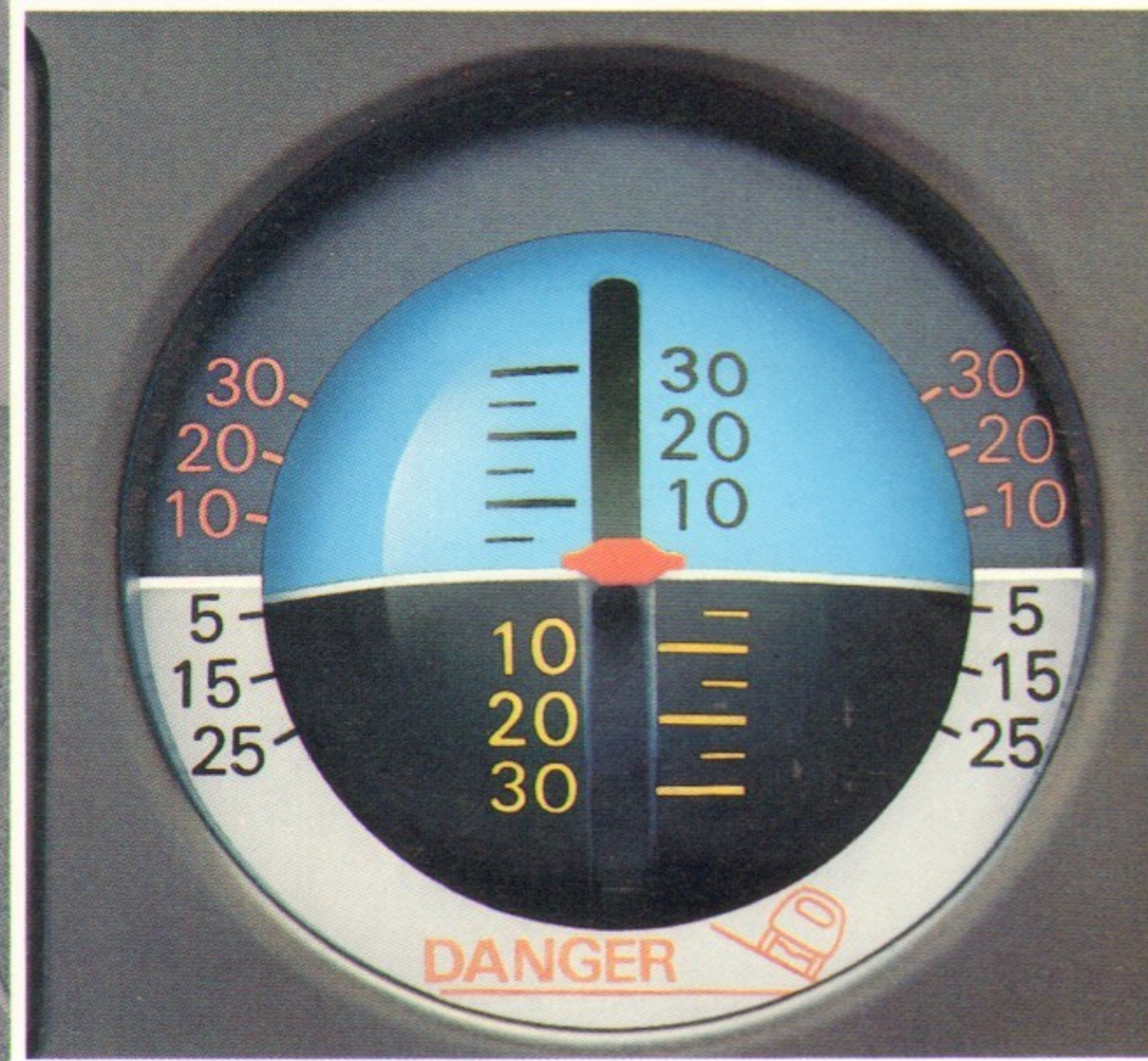
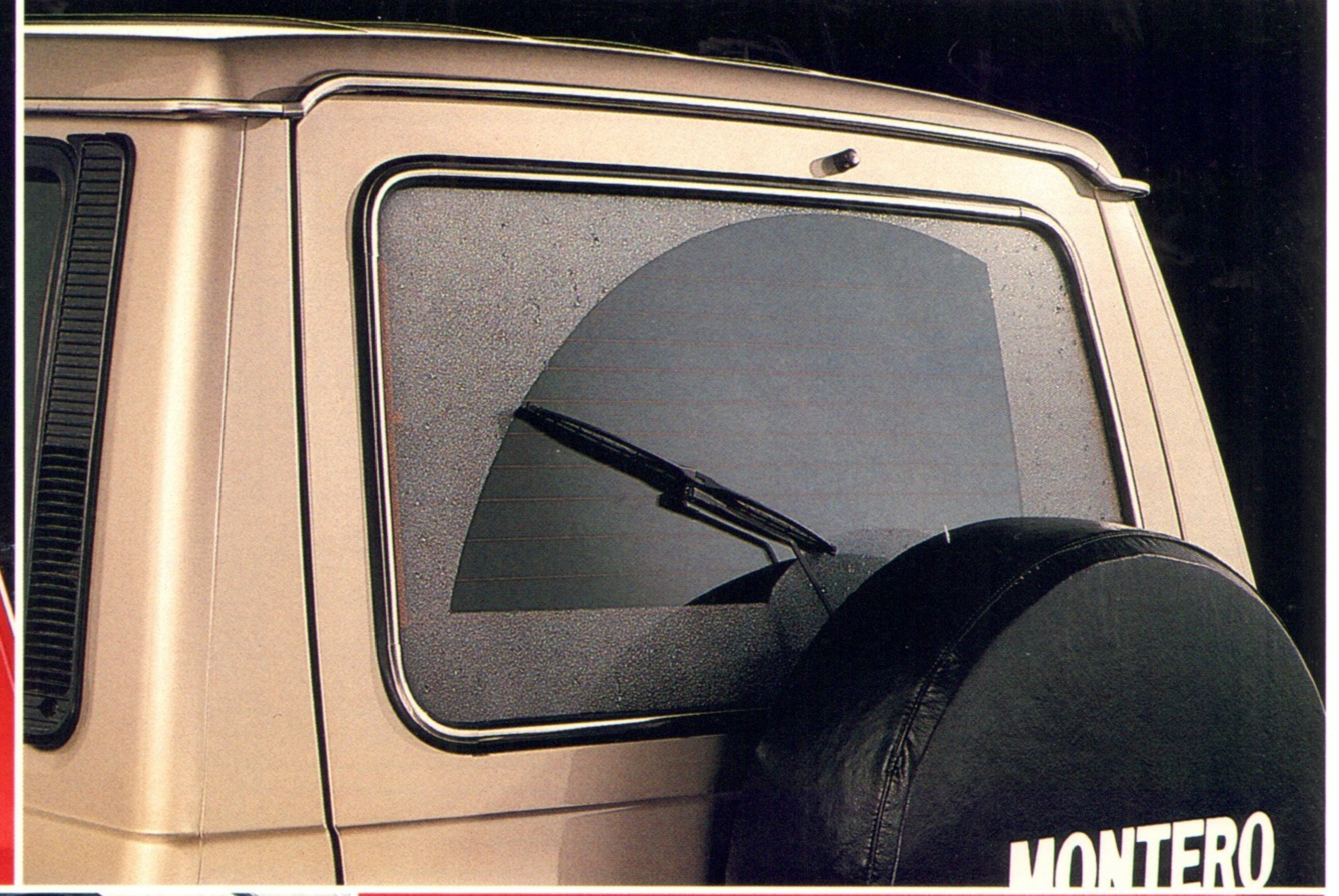

Traveling Music.

Select from three sensational sound systems for your Montero. The electronically tuned AM/FM stereo cassette with four full-range speakers is standard on the Sport, optional on the Montero SP. Or choose the optional electronically tuned AM/FM stereo with 4 speakers for your Montero SP. For the Montero Sport, you have the option of an electronically tuned AM stereo/FM stereo with cassette, 4 full-range speakers and graphic equalizer. All will drive you wild with wonderful sound.

Shift Into Action.

Get off to a running start with Montero's smooth shifting five-speed manual transmission with overdrive.

Easy Going.

Let our optional four-speed automatic overdrive transmission take the work out of driving.

Wheel Good Looking.

Put your Montero on center stage with a set of great looking 15" aluminum alloy wheels, and watch heads turn.

Extra Wide Open Spaces.

Wherever you go, you'll want to make sure you've got the space to take all your gear. So Montero SP's optional dealer installed rear seat folds forward for extra room and cargo carrying space. The rear seat is standard on the Montero Sport.

Easy to Gas Up.

Montero's convenient remote release in the cockpit makes gassing up easier than ever.

Know Where You Stand.

When four-wheel drive is engaged, you'll know it when the "front hubs locked" Indicator light and 4WD Indicator light go on.

Figure the Angles.

When you need to know the angle of a slope, check your inclinometer. It'll tell you at a glance the angle of your climb fore-and-aft and side-to-side.

When You Need a Breeze.

Slide back those side rear quarter windows and let the breezes flow through for complete ventilation.

Private Places.

Front and center, between both low back buckets there is a console storage bin for keeping your gear out of sight.



The Lock Up.

Keep your spare tire under lock and key so it stays safe and secure.

Diamond CareSM... Our Commitment to Quality.

Diamond CareSM Mitsubishi's comprehensive new vehicle delivery program, ensures that your new vehicle is thoroughly prepared, inspected and its features explained before you leave. And Diamond Care does not end when you leave the dealership. After your first 1,000 miles, you are invited to return for a check-up, and if you have any problem caused by normal vehicle use it will be taken care of absolutely free.

Clean it Up.

When the weather turns wet and nasty, put your rear wiper/washer into action. It'll clear up your rearward view instantly. (Optional SP/Standard Sport)

Key Action.

Your gas supply is safe behind Montero's locking fuel-filler door.

A Little Light Clean Up

Every Montero Sport comes with a high pressure spray washer that helps keep the halogen headlamps clean even when you're rambling down dusty trails.

S P E C I F I C A T I O N S

Features & Options

	SP	Sport
MECHANICAL		
2.6-liter, 4-cylinder SOHC engine	S	S
Dual Engine Stabilizers™	S	S
Automatic valve lash adjusters	S	S
Electronic fuel feedback carburetion system	S	S
Stainless steel exhaust system	S	S
5-speed manual overdrive transmission	S	S
4-speed automatic overdrive transmission	O	O
2-speed transfer case	S	S
Independent front suspension	S	S
Front stabilizer bar	S	S
Automatic locking front hubs w/hub engagement light	S	S
Part-time 4WD system	S	S
Limited-slip differential	-	S
Power-assisted vented front disc brakes	S	S
Power-assisted recirculating ball steering	S	S
Maintenance-free battery	S	S
Diamond Care™	S	S
12-month/12,000-mile New Car Limited Warranty*	S	S
36-month/50,000-mile Powertrain Limited Warranty*	S	S
36-month/36,000-mile Electronics Limited Warranty*	S	S
5-year Anti-Corrosion Perforation Limited Warranty*	S	S
COMFORT & CONVENIENCE		
Air conditioning	O	O
Dual bi-level heating/ventilation system	S	S
Rear heater outlets	-	S
Height adjustable steering column	S	S
Sports-style steering wheel	S	S
Power front windows	-	O
Center console w/between-seat storage area	S	S
Fold-down cargo tie-downs	S	S
Passenger assist grips	S	S
Rear assist grips	-	S
Dash-mounted passenger grab bar	S	S
Remote fuel filler door, hood releases	S	S
Remote electric rear door lock switch	S	S
Lockable glovebox	S	S
Illuminated cigarette lighter/front ashtray	S	S
2-speed windshield wiper/washer	S	S
Variable intermittent wiper control	S	S
Electric rear window defroster	S	S
Side window defoggers	S	S
INSTRUMENTATION & CONTROLS		
Tachometer, resettable tripmeter, Inclinator, Oil pressure gauge, Voltmeter	S	S
Digital quartz clock	O	S
Warning lights: Brakes, Battery charge, Door ajar, Seatbelts, Auto-locking hubs engaged, 4WD engaged	S	S
Electronically tuned AM/FM stereo + 4 speakers	O	-
Electronically tuned AM/FM stereo w/cassette + 4 speakers	O	S
Electronically tuned AM stereo/FM stereo w/cassette, graphic equalizer + 4 speakers	-	O

	SP	Sport
VISIBILITY		
Halogen headlamps	-	S
Headlamp washers	-	S
Tinted glass	S	S
Opening front vent windows	S	S
Sliding rear quarter windows	S	S
Rear window wiper/washer w/intermittent control	O	S
Western dual mirrors, bright	-	S
Flag type dual mirrors	S	-
Convex passenger-side mirror	S	S
SEATING & TRIM		
Sport type reclining front bucket seats	S	S
Full-face velour upholstery	S	S
Driver's suspension seat	-	S
Passenger's seat walk-in release	S	S
Fold-forward rear bench seat	-	S
Full carpeting, passenger compartment	S	S
Carpeted cargo area	S	S
Color-coordinated headliner	S	S
EXTERIOR		
Skid plates: front end, transfer case, fuel tank	S	S
Striping, accent	S	-
Front bumper, chrome	-	S
Rear step bumper, chrome	-	S
Rear step bumper, black with bright step	S	-
Grille, black with bright accents	-	S
15.9-gallon fuel tank	S	S
Locking fuel-filler door w/remote release	S	S
Rear window defroster	S	S
Swing-away rear door, electric remote control	S	S
Tow hooks, front & rear	S	S
Mud flaps, front and rear	S	S
Fixed-length whip antenna	O	S
Two-tone paint	-	S
Plastic inner fender liners (front)	S	S
WHEELS & TIRES		
Styled steel wheels w/center cap	S	S
Alloy wheels	O	O
225/75R15 all-terrain steel belted radials	S	S
Rear-mounted full-size spare tire w/lock	S	S
EXTERIOR COLORS/INTERIOR TRIM		
Palermo Gray/Brown	S	S
Selbia Black/Gray	S	S
California Red/Gray	S	S
Bright Silver/Gray	S	S
Baltic Blue/Blue	S	S
Dakar Sand/Brown	S	S
Summit White/Blue	S	S

Technical Specifications

Montero SP/Montero Sport	
ENGINE	
Model No. and Type	G54B, SOHC, 4-cylinder, in-line
Bore & Stroke (in./mm.)	3.59 x 3.86/91.1 x 98.0
Displacement (cu. in./c.c.)	155.9/2555
Compression Ratio	8.7:1
Horsepower @ rpm (BHP)	109 @ 5000
Torque @ rpm (lb-ft)	142 @ 3000
Induction Type	1-2V carburetor
Emission Control System	EGR, air induction, 3-way catalyst w/feedback control
CLUTCH	
Clutch Type	Single-plate, dry; hydraulically actuated
Diameter (in.)	8.86
TRANSMISSION RATIOS (:1)	
5-Speed Manual Overdrive	1st/3.967, 2nd/2.136, 3rd/1.360, 4th/1.000, 5th/0.856, Rev/3.578
4-Speed Automatic Overdrive	1st/2.826, 2nd/1.493, 3rd/1.000, 4th/0.688, Rev/2.703
Final Drive-Ratio	4.625
4-WHEEL DRIVE SYSTEM	
Type	Part-time
Automatic Locking Front Hubs	Standard
Transfer Case Type	2-speed
Ratios—High Range	1.000:1
—Low Range	1.944:1
SUSPENSION	
Front Type	Independent with unequal-length A-arms, torsion bar, telescopic shock absorbers, 0.91-in. stabilizer bar
Rear Type	Live axle on semi-elliptic leaf springs, bias-mounted telescopic shock absorbers
DIMENSIONS	
Chassis/Body Construction	Steel body on ladder frame
Wheelbase (in./mm.)	92.5/2350
Overall Length (in./mm.)	157.3/3995 including spare tire 155.9/3960 without spare tire
Overall Width (in./mm.)	66.1/1680
Overall Height (in./mm.)	72.4/1840—Montero Sport 72.8/1850—Montero SP
Tread Width (in./mm.)	Front—55.1/1400 Rear—54.1/1375
Ground Clearance (in./mm.) @MVMA load	8.3/210-static
Approach Angle (degrees) @MVMA load	38°
Departure Angle (degrees) @MVMA load	28°
Head Room (in./mm.)	Front—36.4/925 Rear—33.9/860
Shoulder Room (in./mm.)	Front—55.1/1400 Rear—57.1/1450
Hip Room (in./mm.)	Front—55.1/1400 Rear—41.3/1050
Leg Room (in./mm.)	Front—39.6/1005 Rear—34.4/875
Cargo Capacity—rear seat folded	62.9 cu. ft. —behind rear seat 22.2 cu. ft.

Montero SP/Montero Sport	
WEIGHTS	
Curb Weight (lbs./kg.)	Montero SP—5M-3185/1445 Montero SP—4A-3240/1470 Montero Sport—5M-3273/1485 Montero Sport—4A-3329/1510
Towing Capacity, maximum (lbs./kg.)	2000/907 (with trailer brakes) 1000/454 (without trailer brakes)
Tongue Weight (lbs./kg.)	200/91 (with trailer brakes) 100/40 (without trailer brakes)
STEERING	
Type	Recirculating ball, power-assisted
Overall Steering Ratio	16.4:1
Turning Circle, Curb to Curb (ft./m.)	34.1/10.4
BRAKES	
Front	Vented disc
Rear	Self-adjusting drum
Diameter Front/Rear (in.)	10.0/10.0 x 2
Total Brake Swept Area (sq. in.)	323
ELECTRICAL SYSTEM	
Battery	12-volt, maintenance-free
Ignition System	Electronic
Alternator Rating (amps)	50
FUEL SYSTEM	
Type Fuel Required	Unleaded (RON 91)
Fuel Pump Type	Mechanical
Fuel Tank Capacity (U.S. gal.)	15.9
WHEELS & TIRES	
Wheel Size and Type	15 x 6JJ styled steel (alloy optional)
Tire Size and Type	P225/75R15 mud & snow rated steel belted radials
Spare Tire Size and Type	Full size

Model	Eng./Trans.	Federal Est. City	Federal Est. Highway
Montero Sport, SP	2.6/5M	17**	19**
Montero Sport, SP	2.6/4A	16**	17**

S = Standard O = Optional - = Not available
* = For complete details, ask your salesperson for a copy of the limited warranty.

**These figures are estimates only, provided by the U.S. Environmental Protection Agency (EPA).

Technical data, features, options and other equipment shown in this catalog are based on the latest available information at the time of printing and are subject to change without notice. Some vehicles are shown with optional equipment. For further information on the additional options and accessories, contact your Mitsubishi Motors Dealer. Availability at dealers of vehicles with specific features may vary. Headlights, parking lights and fog lights on vehicles lighted for illustration purposes only.

Call 1-800-447-4700 for your nearest Mitsubishi Motors Dealer.
Part #MMSA-ADV-5040. Litho in U.S.A. ©1987 Mitsubishi Motor Sales of America, Inc.



Mitsubishi. Suddenly, the obvious choice.

