

S-10 BLAZER



S-10 BLAZER. SOPHISTICATED BRAWN.

S-10 Blazer is the most popular sport utility vehicle in America* for several big reasons...the way it looks, the way it works and the way it plays. That's exactly the way it was designed, to give you a handsome combination of truck-tough character and stylishly attractive lines.

S-10 Blazer was conceived as a workhorse. Its backbone is a sturdy ladder-type frame, beefy enough for the real world. Standard muscle is provided by the 2.5 Liter, electronically fuel-injected Tech IV engine. Or get even more punch with the optional 2.8 Liter V6, electronically fuel-injected for 1986. Team the engine of your choice with the standard 4-speed manual transmission; 5-speed manual overdrive and 4-speed automatic overdrive transmissions are available as well. Plus, there are two types of Blazer to choose from—the 2-wheel-drive

Blazer or the Insta-Trac 4x4 model that lets you shift from 2-wheel drive to 4-wheel-drive High and back without stopping.

But the S-10 Blazer is as street-smart as it is assertive. Sheet metal and glass are attractively integrated; the aerodynamic shape is logical, with excellent visibility and loads of cargo space built in. And inside S-10 Blazer you'll find an interior so comfortable it rivals that found in many automobiles.

Add your choice of creature comforts and what you've got is more than a vehicle: It's a dependable partner when the going gets heavy. It's a stylish pleasure seeker when you make a break for fun.

*Ward's Automotive Reports, January 1983 through September 1985.

Shown on cover: S-10 Blazer Tahoe 4x4 Special Two-Tone in Midnight Black and Apple Red.

Shown at right: S-10 Blazer 4x4 Custom Two-Tone in Steel Gray and Galaxy Blue Metallic. Tires supplied by various manufacturers.





S-10 Blazer Tahoe 2WD in Cinnamon Red. Tires supplied by various manufacturers.

2WD S-10 BLAZER. STYLISH ALTERNATIVE.

Consider the possibilities of a vehicle that offers the flexibility of a station wagon, the comfort of a passenger car and the rugged capabilities of a truck. Consider the 2WD S-10 Blazer, the sportster that hauls a load of lumber just as easily as it transports you to the fanciest restaurant in town.

There are lots of reasons why Blazer adapts so well to virtually any situation. Refined exterior contours that attract admiring attention. Interior seating, when the available rear bench is added, for four long-limbed American adults. Space, when the rear bench is folded, that accommodates 67.3 big cubic feet of cargo. A rear tailgate and lift-glass that make loading and

unloading simple, whether you're heading for the yacht club or checking out the newest boutique.

Of course, the 2WD S-10 Blazer is more than a handy runabout. As a highway cruiser, it's smooth and quiet, with low-pressure gas shocks to give a boulevard-like ride. As a tow truck, it'll handle 5,000 lbs. of

trailer and cargo, when properly equipped. As a fun wagon, it invites you to take the gang fishing. As an escape vehicle, it'll take you away from it all.

When it comes to S-10 Blazer, the possibilities are endless. That's what makes Blazer such an attractive alternative to more conventional ways to get around.





S-10 Blazer Tahoe 4x4 Custom Two-Tone in Doeskin Tan and Nevada Gold Metallic. Tires supplied by various manufacturers.



S-10 BLAZER 4X4. OFF-ROAD RUNNER.

True—it doesn't fly and it doesn't float. But there's a lot of ground to cover between those two extremes, and Chevy's aggressive S-10 Blazer 4x4 is ready, willing and eager to run out and explore.

The guts of this trail-blazing 4x4 is the patented Insta-Trac 4-wheel-drive system. This system is handy as well as ingenious, letting you shift from 2-wheel drive to 4-wheel-drive High and back again on the run. With S-10 Blazer there are no hubs to lock, no multiple levers to shift. Obviously, that's a real advantage when you're miles from civilization and Mother Nature puts obstacles in your way.

But Insta-Trac is just part of S-10 Blazer's 4x4 story. From craggy ridge tops to desert-canyon depths, S-10 4x4 moves with the resolute mus-

cle of independent torsion bar front suspension, the freedom of ample ground clearance and the confidence of self-adjusting front disc/rear drum brakes. All the while, this back-country runner uses a carefully designed suspension system and ergonomically constructed seats to cushion the passengers riding inside.

And by adding the available Off-Road Package, which includes Delco/Bilstein gas high-pressure shocks, front stabilizer bar and

requires the optional 2.8 Liter V6 engine, you can beef up your S-10 Blazer 4x4 even more.

So go ahead. Push the outer limits. S-10 Blazer 4x4 is the way to go, no matter which off-road extreme you decide to explore.





Tahoe interior in Blue Custom Cloth.

INSIDE S-10 BLAZER. THE GREAT INDOORS.

Step inside S-10 Blazer. It's not what you thought the inside of a truck would be like. But then again, S-10 Blazer is a lot more than just a truck.

Slide into the standard high-back bucket seats. Feel how they support you with firm, full-foam cushioning. Then stretch out. There's plenty of room for long, lanky legs. The available rear seat, which holds two adults, also has plenty of leg room, while still offering 28.1 cu. ft. of cargo space behind.

And getting to the back is easy with the front passenger "memory seat." Fold it forward for rear seat access and it'll return to its original setting with just a gentle nudge.

In available Tahoe trim, shown above, S-10 Blazer sports upholstery in your choice of ventilated Custom Vinyl or Special Custom Cloth, color-keyed carpeting and kick panels, zippered rear pockets, additional insulation and a gage package with trip odometer. Exterior appearance items, like bright wheel opening moldings and tailgate applique, announce your appreciation of life's finer things to the world outside.

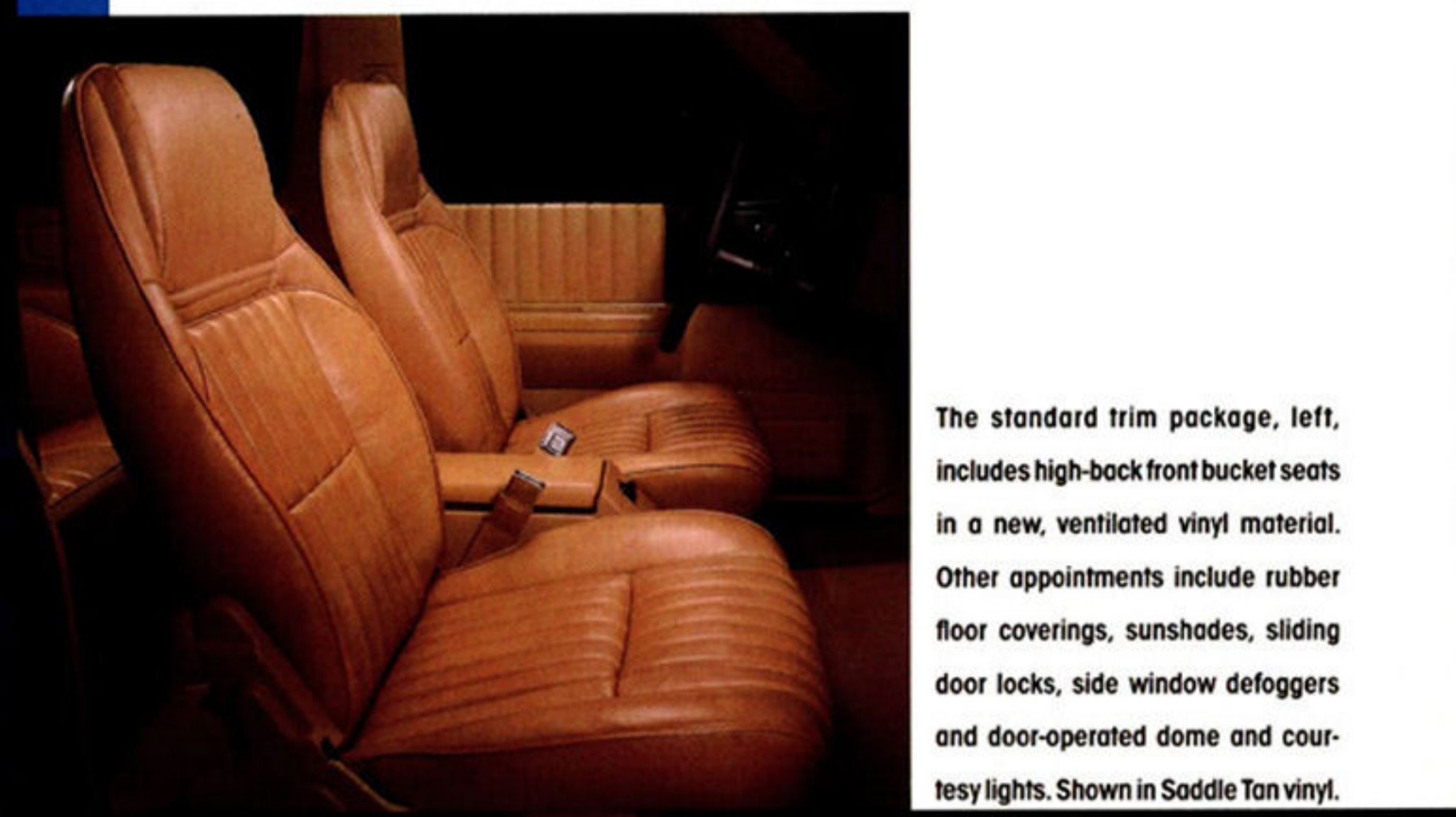

The standard trim package, left, includes high-back front bucket seats in a new, ventilated vinyl material. Other appointments include rubber floor coverings, sunshades, sliding door locks, side window defoggers and door-operated dome and courtesy lights. Shown in Saddle Tan vinyl.



S-10 Blazer's available top-of-the-line Sport interior, right, includes reclining bucket seats, locking console, full carpeting and Sport steering wheel. The Saddle Tan Deluxe Cloth seat trim is new for 1986.



High-tech-type instrument cluster new for 1986.

New Tahoe instrument panel.

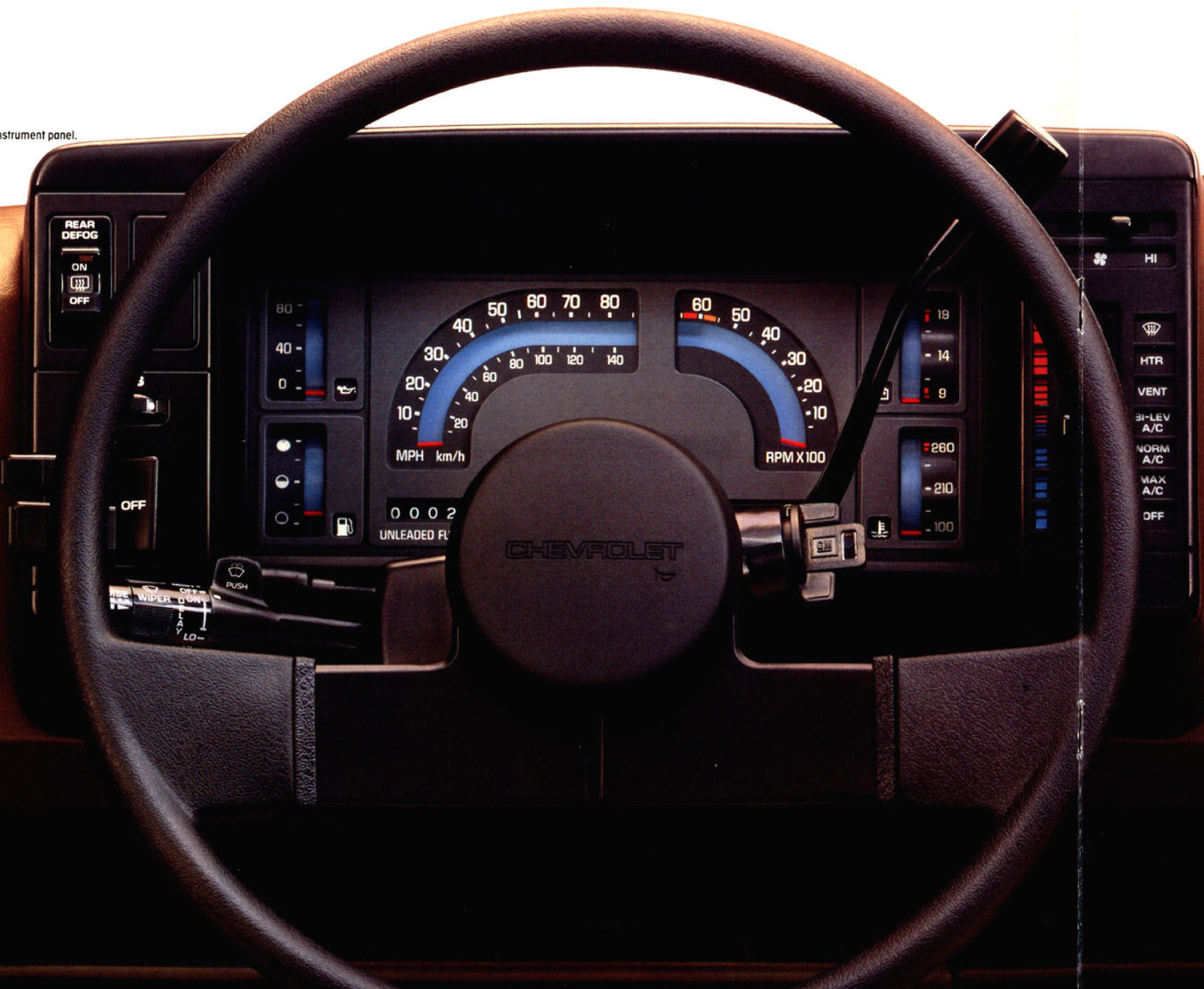

S-10 BLAZER UP FRONT. DRIVING COMMAND.

Highlighting S-10 Blazer's driving environment is this all-new command center. The instrument panel, which features a high-tech appearance, includes improved controls and cluster. New tell-tale warning lights sit to either side of the speedometer/fuel gage combination. New steering wheels in all three trim levels carry out the contemporary look. For added convenience, a new

parcel tray organizes little things while driving.

Enhancing your control of the vehicle is placement of the driving systems for fingertip-handly access. Visibility is good in all directions. And on 4x4 models, the Insta-Trac console is strategically placed to the right of the driver's seat.

Of course, the driving experience consists of more than just guiding a vehicle. So S-10 Blazer makes a variety of other pleasurable accoutrements available, including air conditioning, a complete gage package (included with Tahoe and Sport) and your choice of five available sound systems. For concert-hall-

quality reproduction, select the electronically tuned GM-Delco AM stereo/FM seek and scan and stereo

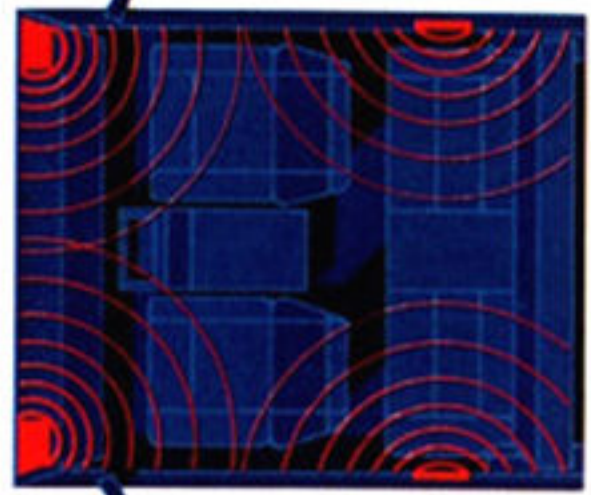

cassette unit with quartz clock, shown below. Four speakers, placed front and rear, make driving a particular pleasure each time you take to the road.



S-10 BLAZER ENGINEERING. ANATOMY OF A TOUGH TRUCK.

Chevy knows how you want your Blazer—tough. And you want proof that Blazer's rugged character is more than just talk.

To show you what goes into making this vehicle such a tough customer, the diagram highlights some of S-10 Blazer's design and construction details. Many features were created through advanced techniques of computer-aided design and manufacturing. Others grew out of real-world use and testing—yours and that of the engineers. And if you think you're rough on a truck, imagine what an engineer probing the limits of his creation can do.

Study the diagram carefully; it'll help you appreciate why Chevy S-10 Blazer is the best-selling vehicle of its kind in America. You'll see the kind of fortitude and determination it takes to be a Chevy tough truck.

Tech IV Engine. Among the continued improvements being made to S-10 Blazer are changes in the standard Tech IV engine. This 2.5 Liter electronically fuel-injected powerplant incorporates lighter-weight pistons and revised valve seat geometry for 1986. Lower reciprocating forces, cooler operation and improved durability resulting from increased surfaces contact area help place the Tech IV engine among the most modern in the lineup.

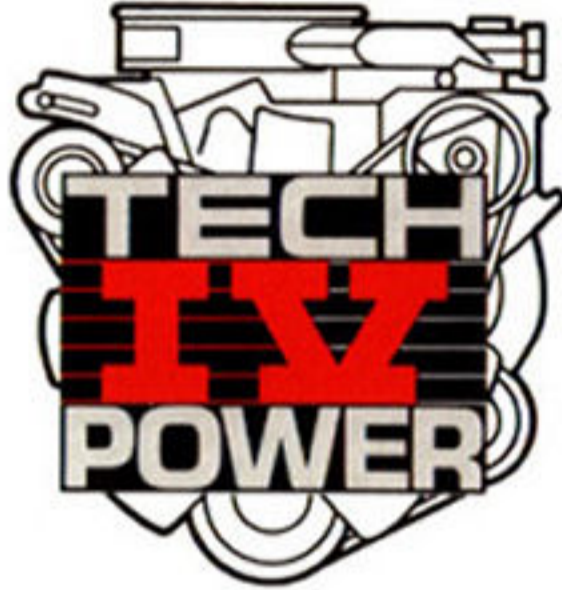

try for 1986. Lower reciprocating forces, cooler operation and improved durability resulting from increased surfaces contact area help place the Tech IV engine among the most modern in the lineup.

New Delcotron generator has 85-amp capacity, simplified design, higher charging rate at idle and is smaller and lighter than previous units.

The available 2.8 Liter V6 engine features Electronic Fuel Injection for 1986. Use of EFI results in a more precise fuel-to-air ratio and improved performance.

The available 5-speed overdrive manual transmission for added performance punch.

Variable-ratio steering gear allows easy parking and quick road response.

Four-layer paint finish has a fifth, chip-resistant coat added to lower body side panels.

Full-frame, hot-wax coating helps fight the effects of dirt and road salt.

Precision stampings designed for quiet, rattle-free, well-sealed fit.

Double-wall construction in windshield pillars, cowl, hood, front fenders, tailgate, rear side panels.

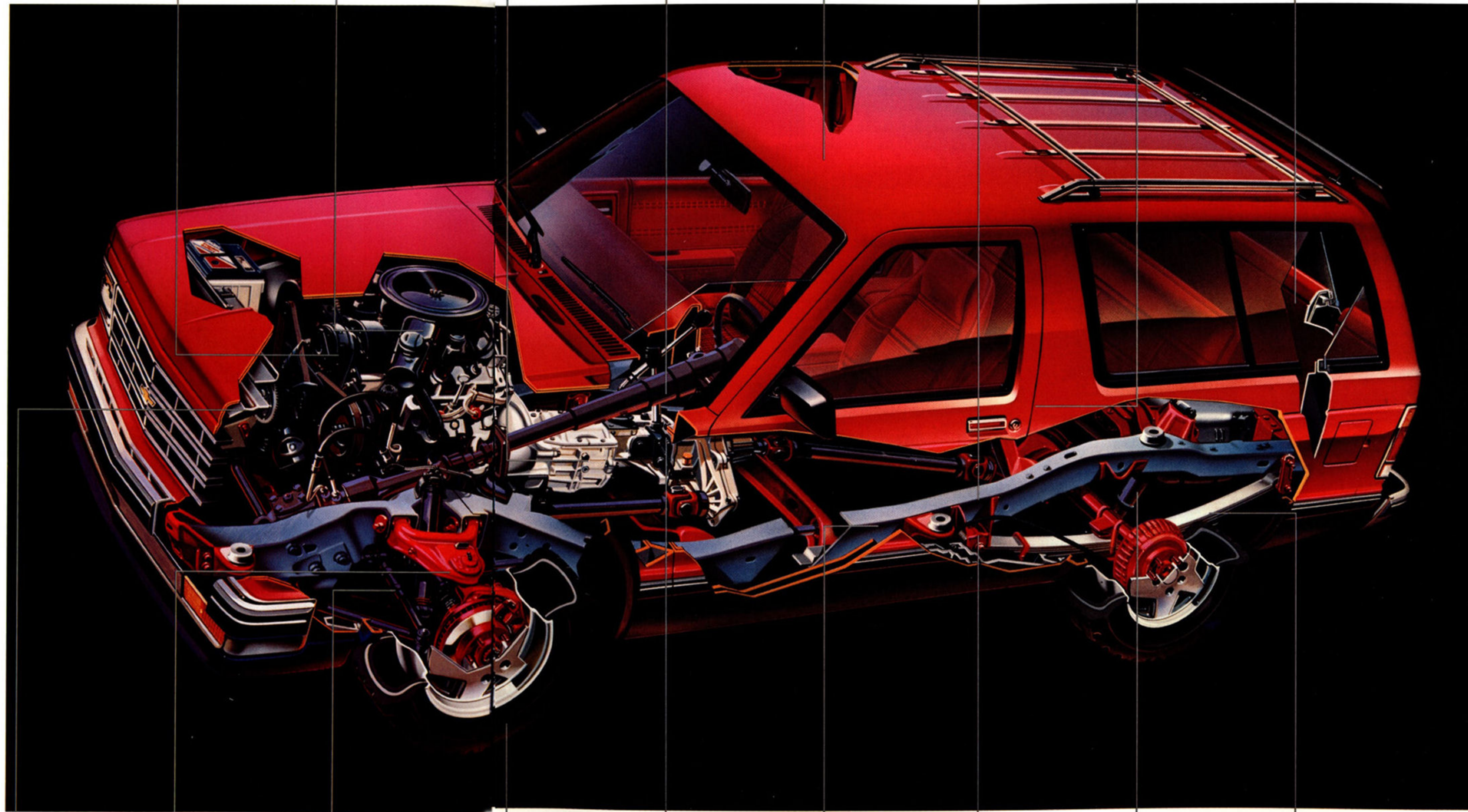

New radiator design pares excess weight and improves durability.

4x4 independent front suspension lets front wheels work individually for impressive ride and handling.

Rubber-bushed upper and lower control arms with lower torsion bar provide 4x4 riding comfort.

S-10 Blazer features 7.1-inch front-axle and 8.2-inch rear-axle ground clearance on 4x4 models when equipped with available P235/75R-15 steel-belted radial tires.

The self-adjusting hydraulically operated clutch offers smooth, light-effort operation and long wear.

Sturdy ladder-type frame is designed for structural rigidity.

Wire-wrapped brake lines are coated with Zincroterne® to help fight corrosion.

Low-pressure gas shocks help deliver a smooth ride.

Two-stage multileaf rear springs adjust to the load for smooth ride.



S-10 Blazer's available Heavy-Duty Trailering Package gives you 5,000 lbs. of towing capacity in the 2WD model, including trailer and cargo. (4,000-lb. capacity in the 4x4 model.)



With the proper equipment, S-10 Blazer 4x4 is ready to dig you out of a blizzard. Electronically fuel-injected 2.8 Liter V6, automatic transmission, heavy-duty front suspension and other optional equipment is required. See your Chevy dealer for complete details.

S-10 BLAZER FEATURES. ADAPTABLE VERSATILITY.

One of the best things about S-10 Blazer is that you can custom-order one just about any way you want it. By adding available equipment, features and packages, you can create an S-10 Blazer with a personality that fits your needs. From towing to snow plowing, from hauling to highway cruising, 2-wheel drive or 4x4, there's an S-10 Blazer for you.



With the optional rear seat folded down, you've got 67.3 cu. ft. of cargo room.

Wagon-style tailgate and lift-glass make rear load space easy to use. Shown: S-10 Blazer Sport Two-Tone in Doeskin Tan and Midnight Black. Tires supplied by various manufacturers.



OPTIONS.



Reclining front bucket seats shown in Saddle Tan High Country Sheepskin.

Performance & Heavy-Duty Equipment Options

	Standard	Tahoe	Sport
Color Climate Package	0	0	0
Cooling, H.D.: Radiator,			
Transmission Oil Cooler	0	0	0
Cruise Control	0	0	0
Fuel Tank, 20-gallon	0	0	0
Gages: Voltmeter, Temperature,			
Oil Pressure with Trip Odometer	0	S	S
Heavy-Duty Battery	0	0	0
Heavy-Duty Front & Rear Shocks	0	0	0
Locking Rear Axle Differential	0	0	0
Off-Road Chassis Equipment			
(4WD models)	0	0	0
Power Steering	0	0	0
Tachometer	0	0	0
Tailgate Window Release	0	0	0
Trailer Special Equipment	0	0	0
Transfer Case Shield			
(4WD models)	0	0	0

0—Optional S—Standard

S-10 Blazer Special Two-Tone in Apple Red and White. Shown with luggage rack, rear window defogger, air deflector, load-distributing hitch platform and rear spare tire carrier (cover included) with cast aluminum wheel. Tires supplied by various manufacturers.

Brush guard (dealer-installed).



Appearance and Convenience Options

	Standard	Tahoe	Sport
Air Conditioning	0	0	0
Bumper Equipment:			
Front & Rear—Painted.			
Color-Keyed			
(requires Two-Tone paint)	0	0	S
Guards, Front Black	0	0	0
Center Console, Floor Mounted	0	0	S
Chromed Grille	S	S	S
Cigarette Lighter	S	S	S
Color-Keyed Floor Mats	NA	0	0
Comfortilt Steering Wheel	0	0	0
Defogger, Rear Window	0	0	0
Glass:			
Deep-Tinted	0	0	0
Deep-Tinted with Light-Tinted			
Rear Window	0	0	0
Deep-Tinted Sliding Rear			
Quarter Windows	0	0	0
Intermittent Windshield Wipers	0	0	0
Lighting Equipment:			
Engine Compartment Lamp	0	0	0
Halogen Headlamps	0	0	0
Luggage Carrier or			
Rear Air Deflector	0	0	0
Mirrors:			
Dual Below Eyeline Type,			
Painted	0	0	0
Chrome	0	0	0
Moldings:			
Body Side and Wheel Opening	0	S	S
Door Edge Guards	0	0	0
Wheel Opening, Bright	0	S	NA
Wheel Opening, Black	0	0	S
Operating Convenience Package			
Includes:			
Power Door Locks, Power Windows	0	0	0
Paint Options:			
Custom Two-Tone	0	0	NA
Special Two-Tone	0	0	NA
Sport Two-Tone	0	0	S
Striping (requires solid paint)	0	NA	NA
Radio Equipment, GM-Delco:			
AM Radio	0	0	0
AM/FM Radio	0	0	0
AM/FM ETR* Stereo Radio	0	0	0
AM/FM ETR Stereo w/Clock	0	0	0
AM/FM ETR Stereo w/Cassette			
Tape, Clock and Seek and Scan	0	0	0
AM Stereo*/FM Stereo ETR Radio			
with Seek and Scan, Stereo			
Cassette Tape with Search and			
Repeat, Graphic Equalizer and			
Digital Clock	0	0	0
Speakers, Premium Dual Rear	0	0	0
Seats: Folding Rear Bench	0	0	0
Sliding Rear Quarter Window	0	0	0
Spare Tire Cover	0	S	S
Wheels:			
Styled (2WD models)	0	0	0
Cast Aluminum (4WD models)	0	0	0
Wheel Trim: Bright Trim Rings	0	S	S

0—Optional S—Standard NA—Not Available

Receives C-Quam AM stereo broadcasts. C-Quam is a registered trademark of Motorola, Inc.

Some options may require the purchase of other options. See your dealer for details.



5-speed manual transmission with overdrive.



Distinctive black chrome grille is part of the Sport trim package.



GM-Delco AM/FM stereo radio with cassette deck, seek and scan and digital clock.



The Off-Road Chassis Package includes Delco/Bilstein gas high-pressure shocks, special torsion bars, front stabilizer bar, transfer and fuel tank shield and P235/75R-15 radial tires with full-size spare, making your Blazer tough enough to conquer almost any kind of terrain.



Below Eyeline mirror.

Styled steel wheels (2WD only).



Cast aluminum wheels (4x4 only).



OPTIONS AND FACTS.

S-10 Blazer Paint Options

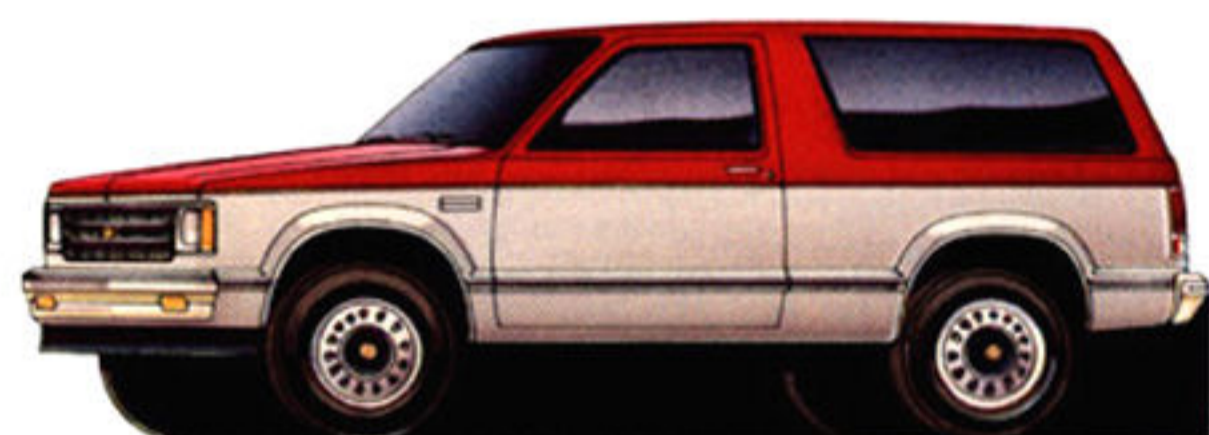

Custom Two-Tone includes decal striping with Color Code 2 applied below the beltline.



Sport Two-Tone includes a four-stripe decal below the crease line, with Color Code 2 applied below the decal.



Special Two-Tone includes Color Code 2 on areas between the molding and the crease line.

Interior and Exterior Color Availability Chart

Interior Colors by Trim Levels		Blue	Carmine	Charcoal	Saddle Tan
STANDARD INTERIOR Custom Vinyl High-Back Bucket Seats					
TAHOE Custom Vinyl High-Back Bucket Seats					
Special Custom Cloth High-Back Bucket Seats					
High Country Sheepskin High-Back Bucket Seats*					
SPORT Deluxe Cloth High-Back Bucket Seats					
High Country Sheepskin High-Back Bucket Seats*					
Exterior Colors		Color Code 1	Color Code 2	Recommended Interior Trim Color	
BLACK, MIDNIGHT					
Gold, Nevada (Metallic)					
Red, Apple					
Silver (Metallic)					
White, Frost					
BLUE, GALAXY (Metallic)					
Silver (Metallic)					
White, Frost					
BLUE, LIGHT (Metallic)					
Blue, Galaxy (Metallic)					
White, Frost					
BRONZE, INDIAN (Metallic)					
Gold, Nevada (Metallic)					
Silver (Metallic)					
White, Frost					
GOLD, NEVADA (Metallic)					
Black, Midnight					
White, Frost					
GRAY, STEEL (Metallic)					
Black, Midnight					
Blue, Galaxy (Metallic)					
Red, Apple					
Silver (Metallic)					
White, Frost					
RED, APPLE					
Black, Midnight					
Silver (Metallic)					
White, Frost					
RED, CINNAMON					
Black, Midnight					
White, Frost					
TAN, DOESKIN					
Black, Midnight					
Gold, Nevada (Metallic)					
White, Frost					
WHITE, FROST					
Black, Midnight					
Blue, Galaxy (Metallic)					
Gold, Nevada (Metallic)					
Red, Apple					
Silver (Metallic)					

*With YC2 Tahoe, rear seat trim is Special Custom Cloth; with YC3 Sport, rear seat trim is Deluxe Cloth.

Specifications	Two-Wheel Drive	Four-Wheel Drive
Payload (lb.)	1000	1000
GVWR Range (lb.)	3880-4600	4125-4880
Engine—Liter (cu. in.)	Std. 2.5 (151) Tech IV Opt. 2.8 (173) V6	2.5 (151) Tech IV 2.8 (173) V6
Front Suspension	Type Independent/Coil Springs Capacity 2200	Independent Driving/Torsion Bar 2400
Rear Suspension	Axle Type Semi-floating Capacity 2600	Semi-floating 2700
Brakes—Disc/Drum	Std. Power	Power
Steering—Type	Std. Manual Opt. Power	Manual Power
Transmission	Std. 4-Sp. Manual Opt. 5-Sp. Manual/O.D. Opt. 4-Sp. Automatic/O.D.	4-Sp. Manual 5-Sp. Manual/O.D. 4-Sp. Automatic/O.D.
Transfer Case	—	N.P. 207
Tubeless Tires	Std. P195/75R-15 Opt. Larger Size Tubeless Tires	P195/75R-15 Larger Size Tubeless Tires*

Engine Specifications		
Displacement—Liter (cu. in.)	2.5 (151) Tech IV	2.8 (173) V6
Engine Ordering Code	LN8	LL2†
Bore & Stroke (in.)	4.00 x 3.00	3.50 x 2.99
Compression Ratio	9.0 to 1	8.5 to 1
SAE Net Horsepower @ RPM	92 @ 4400	125 @ 4800
SAE Net Torque (lb.-ft.) @ RPM	134 @ 2800	150 @ 2200

*Including P235/75R-15 on- and off-road tires, which do not accept tire chains.
†Produced in U.S., Canada or Mexico.

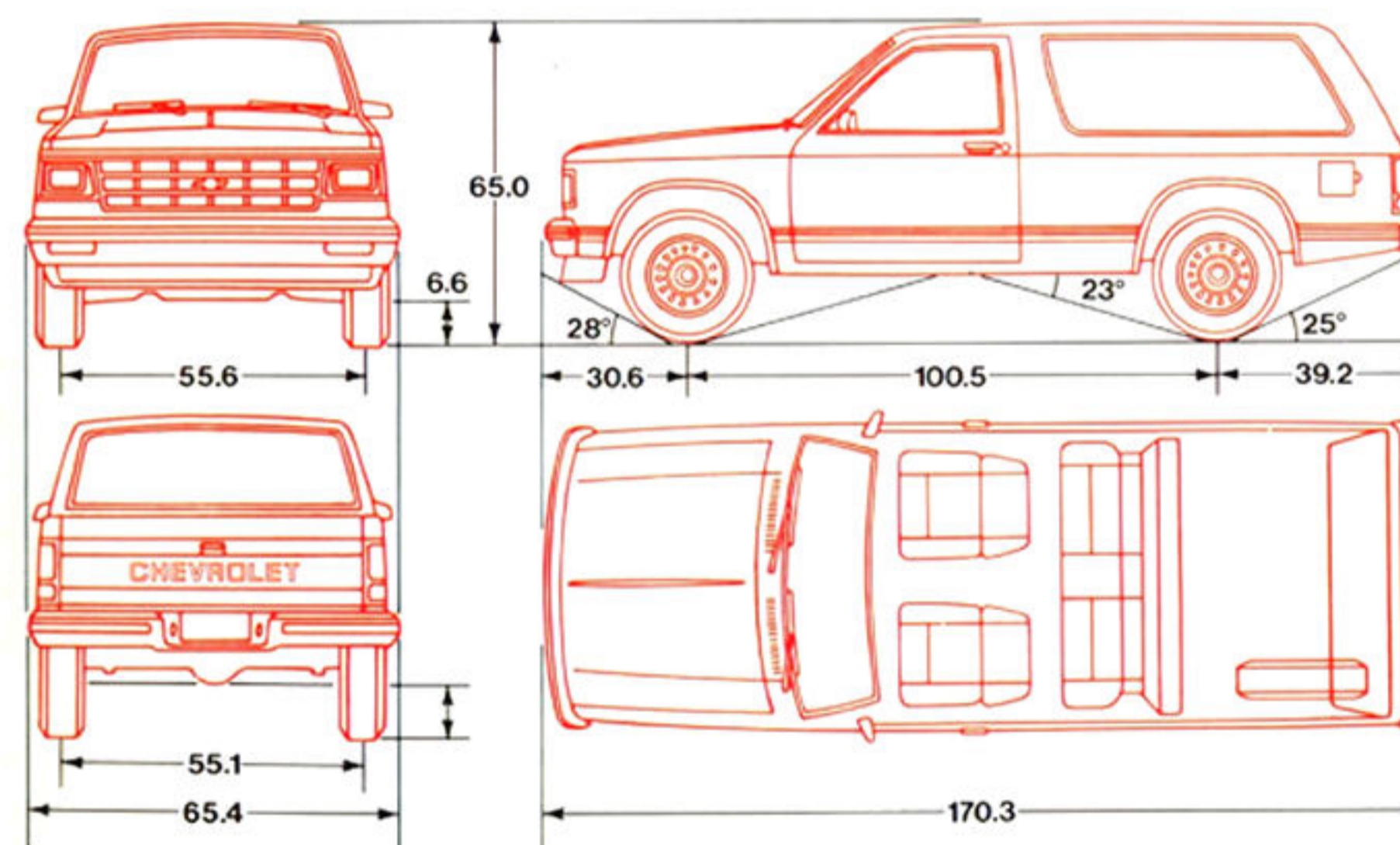

As part of the 1986 Chevrolet new-vehicle limited warranty, your Chevy truck includes three-year perforation-from-corrosion coverage. Exhaust system components not included. See your Chevy dealer for details and other limitations.

A word about engines. Chevrolet trucks are equipped with engines produced at facilities operated by GM car and truck groups, subsidiaries or affiliated companies worldwide.

At your Chevy dealer's, financing or leasing your new S-10 Blazer can be as easy as saying GMAC.

The GM Protection Plan. An option that offers service protection in addition to that provided by GM's new-vehicle limited warranty. Available only in the U.S. and Canada for the 1986 model year. Ask your dealer about this option.

For information on any new Chevy truck. See your Chevy dealer for a complete selection of 1986 truck catalogs. They cover ■ full-size 4WD Blazer ■ Chevy S-10 Pickup ■ full-size Chevy Pickup ■ Suburban ■ El Camino ■ Sportvan ■ Chevy Van ■ Astro Passenger Van ■ Astro Cargo Van ■ all Medium-Duty Chevys and the ■ Chevy Recreation & Trailering Guide.

Important: A word about this catalog. We have tried to make this catalog as comprehensive and factual as possible. However, since the time of printing, some of the information you will find here may have been updated. Also, some of the equipment shown or described throughout this catalog is available as factory-installed options, dealer accessories and specialized equipment from various independent suppliers at extra cost. Your dealer has details and, before ordering, you should ask him to bring you up to date. The right is reserved to make changes at any time, without notice, in prices, colors, materials, equipment, specifications and models. Check with your Chevrolet dealer for complete information.

Let's get it together . . . buckle up. Every new 1986 S-10 Blazer delivered by a Chevrolet dealer in the United States comes with a one-year, \$10,000 safety belt user insurance certificate from MIC General Insurance Corporation at no additional charge. \$10,000 will be paid to the estate of any occupant who suffers fatal injuries as a result of an accident involving that vehicle while wearing a GM safety belt. Buckle up every time you drive.

A word about updated service information. Chevrolet regularly sends its dealers useful service bulletins about Chevrolet products. Chevrolet monitors product performance in the field. We then prepare bulletins for servicing our products better. Now you can get these bulletins, too. Ask your dealer. To get ordering information, call toll-free 1-800-551-4123.

A word about assembly, components and optional equipment in these Chevrolet products. The Chevy Blazers described in this catalog (Series S-10 2WD and 4WD) are assembled at facilities operated by General Motors or GM of Canada. These vehicles incorporate thousands of different components produced by car and truck groups and various component divisions of GM and by various suppliers worldwide to General Motors. From time to time during the manufacturing process, it may be necessary, in order to meet public demand for particular vehicles or equipment, or to meet federally mandated emissions, safety and fuel economy requirements, or for other reasons, to produce Chevrolet products with different components or differently sourced components than initially scheduled. All such components have been approved for use in Chevrolet products and will provide the quality performance associated with the Chevrolet name.

With respect to factory-installed extra-cost optional equipment, make certain you specify the type of equipment you desire on your vehicle when ordering it from your dealer. Some options may be unavailable when your car is built. Your dealer receives advice regarding current availability of options. You may ask your dealer for this information. GM also requests the dealer to advise you if an option you ordered is unavailable. We suggest that you verify that your vehicle includes the optional equipment you ordered or, if there are changes, that they are acceptable to you.

These vehicles are also available under the GMC nameplate Jimmy Series S-15: 2WD and 4WD.

Commitment to Excellence Chevrolet enhances your ownership experience with its "Commitment to Excellence," a customer satisfaction program that brings you an extensive system of services and benefits. The program includes: ■ Vehicle identification cards to speed your service request at the dealership. ■ Special rates and reservation service at participating hotels, motels and car rental agencies. ■ Hotel/motel and car rental guides. ■ Pre-registered key return service. ■ A "Let's Talk" booklet of service signals. ■ A glove compartment organizer. ■ An improved delivery procedure that includes an inspection checklist and orientation drive. Chevrolet's "Commitment to Excellence" is another way Chevrolet takes care of you for as long as you own your truck.

Tire chains should not be used on an S-10 Blazer equipped with P235/75R-15 tires because they may cause damage to this vehicle.

Shown on back cover: S-10 Blazer Tahoe 4x4 in Galaxy Blue Metallic. Tires supplied by various manufacturers.

NOTHING WORKS LIKE A CHEVY TRUCK

