

# FORD FALCON GLi



HAVE YOU DRIVEN A FORD...LATELY?



# FORD FALCON GLi



HAVE YOU DRIVEN A FORD...LATELY? 



TAKING  
AUSTRALIA'S  
FAVOURITE  
FAMILY CAR  
FURTHER.

When you cast your eyes over the new Ford Falcon GLi, you're looking at the product of thirty years intensive and continuous development.

Three decades' worth of work dedicated to just one purpose: making successive generations of Falcons good enough to gain and hold the position of Australia's favourite family car.

Today, the competition is fiercer than ever. Which means that for continued success this Falcon has to perform at a level of automotive sophistication unimagined in

Australian cars just a few years ago.

With each new Falcon, Ford has sought to set constantly improving standards for comfort, space, ride, handling and performance in a family car. And the latest model is no exception. This Falcon builds on the reputation earned by its predecessors by taking the marque into new areas of power, advanced technology and safety.

In styling, Falcon leaves the competition on the outside looking in. The exterior displays the clean and uncluttered lines that have made the current Falcon body shape so appealing to so many. While the interior is trimmed in a range of new fashion co-ordinates. Ride and handling continue to be both comfortable and confidence building.

Under the bonnet, Falcon powers ahead with a new 4 litre, multipoint electronic fuel injected six cylinder engine. And the uncompromising power of Ford's famous five litre V8 is also available as an extra cost option.

This Falcon provides additional safety features such as belt locker systems for front seat belts, increased roof strength and an optional Anti-lock Braking System at extra cost.

In thirty years, a lot of drivers have come to trust Falcon to deliver everything they ask for in a family car - including value. This Falcon goes even further by giving you even more. Falcon can look back with pride on a great heritage. And buyers of the new Falcon can look forward to a great future.

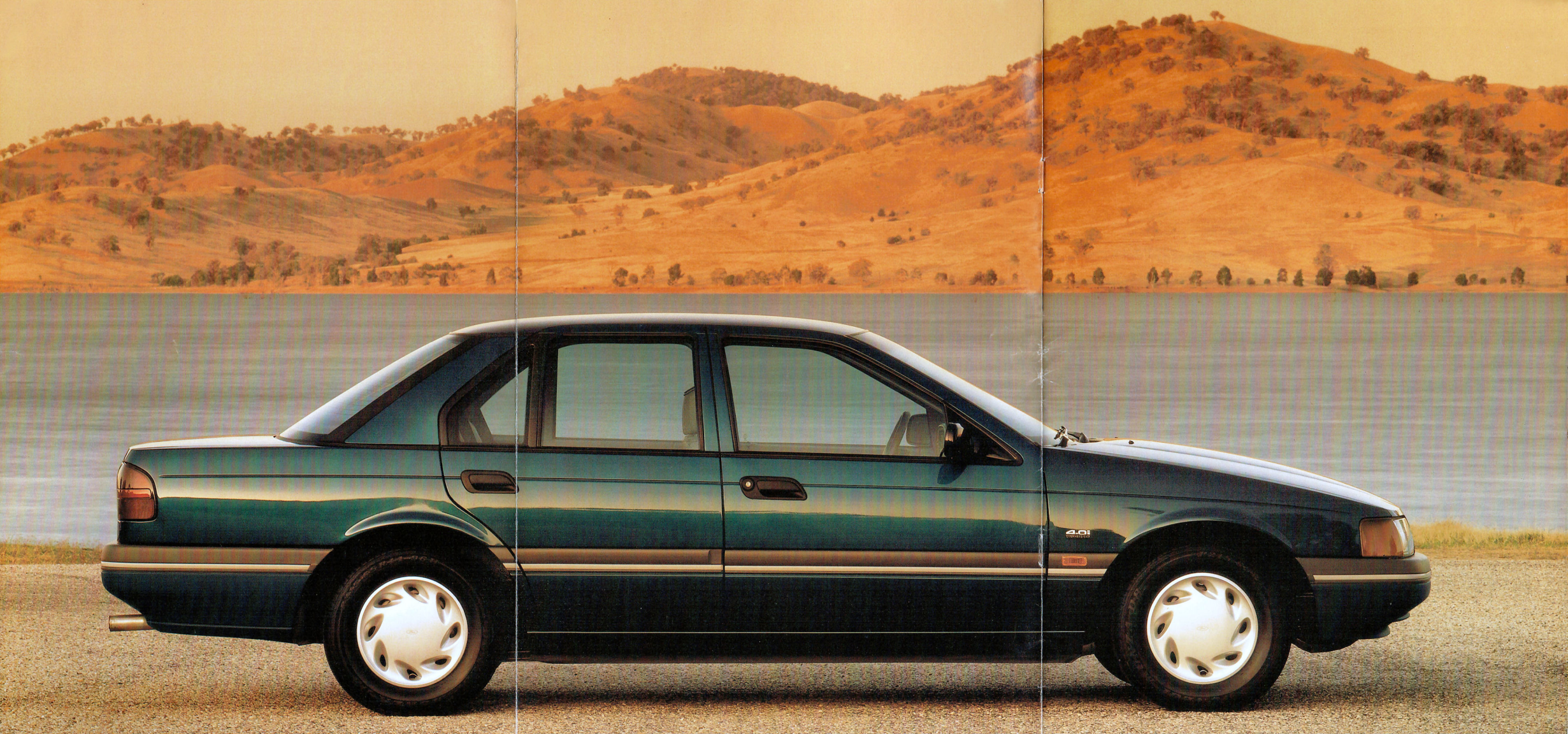



THE BEAUTY OF  
INNER SPACE.

Take a seat inside Falcon GLi and your first impression is of tremendous comfort and spaciousness.

It's a feeling that never leaves you. Even in situations like city traffic jams or travelling endless country roads, Falcon GLi can make being on the road enjoyable.

The feeling of spaciousness is enhanced by the interior trim, which features co-ordinated light tones and colours.

Falcon comfortably accom-

modates five adults, or six with the optional Centafold front seat. And the standard 60/40 split fold rear seat back enables you to carry long or awkward bootloads in addition to



one or two rear seat occupants.

But for ultimate space there's the Falcon GLi wagon. With a 2622 litres maximum capacity, it's the biggest in its class.

STYLE AND  
COMFORT.

Sheer space alone doesn't make a big car great; it's the way the space is used that's important. And in Falcon GLi there's enough head, shoulder and leg room to let you really stretch out. You're also comfortably supported in seats trimmed in 'Saville' and 'Tivoli' cloth that beautifully co-ordinates with Falcon's other interior materials.

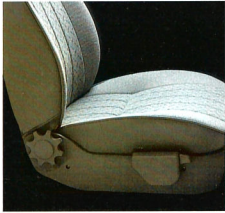

The driver, deservedly, receives special attention. He benefits from a left-foot footrest while his seat adjusts fore-and-aft and for height.

The seat has adjustable tilt and has a lowerback comforting adjustable lumbar support.

Front headrests that adjust and moulded door trims with built-in armrests help take some of the strain out of a long trip. And rear outlet ducts in the centre console provide fresh air to rear seat passengers.



TAKING  
CONTROL.

With controls at your fingertips and conveniently arranged instrumentation, the Falcon GLi driver is always in a position to know what his car is doing. Twin levers on either side of the steering column take care of the steering column flash/dip and washer/wipers.

The steering column itself is adjustable in both rake and reach so it can be positioned to give any driver more precise control. For comfort and convenience, power exterior mirrors are standard equipment.

Across the dashboard are controls for an efficient and effective heater/ventilation system, rear screen demist, analogue instruments

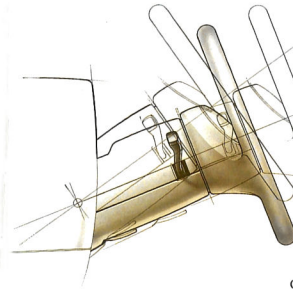

Adjustable steering column for comfort and control.

including fuel and temperature gauges, speedometer and warning lights for six functions.

There are ample storage spaces provided including a lidded console bin between the front bucket seats.

And entering and leaving Falcon GLi is made easy with standard power door locks fitted.

SOUND  
SECURITY  
MEASURES.

To help combat crime, Falcon GLi is equipped with a variety of theft deterrent devices.

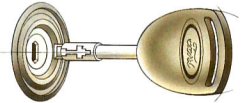

Unique high security Tibbe locks are fitted.

Doors, ignition and boot/tailgate feature high-security 'Tibbe' locks. As a deterrent against unauthorised entry, door lock buttons are recessed. The ignition lock barrel is heavily reinforced to further improve security. And individually unique Vehicle Identification Numbers are permanently marked on major vehicle components to help deter theft.

Falcon GLi's advanced AM/FM stereo radio with cassette player features four speakers, auto reverse, auto scan, LCD display, auto store and digital clock. It is protected by a security code that renders it useless to thieves. And an even more sophisticated Deluxe Sound System with eight individual speaker elements is available as an extra cost option.



S A F E T Y .  
A N I S S U E Y O U  
C A N ' T A V O I D .

There's no sense denying that the road is a potentially dangerous place. So Ford has always had an ongoing commitment to continuously improving vehicle safety.

Over successive generations of vehicles, Ford has incorporated an increasing number of safety features into Falcon.

Primary safety features include engines with sufficient power not to be found wanting when extra response is called for. Steering and suspension systems that are precise and predictable. Powerful braking systems, that include four wheel discs and an optional Anti-lock Braking System. But because, even though it may not be you or your

car's fault, collisions do occur, Falcon's secondary safety features are so important. The list includes integral vehicle crumple zones and strengthened passenger compartments, inertia reel seat belts with reinforced mountings and belt lockers. In fact, Ford takes safety so seriously that Falcon not only meets but significantly exceeds many of the safety standards laid down.

Of all the features on your new Ford, the ones concerning safety are the ones we hope you never have to think about. But if you do, it's good to know that the engineers at Ford have done a lot of thinking for you. And here are some of our latest thoughts.

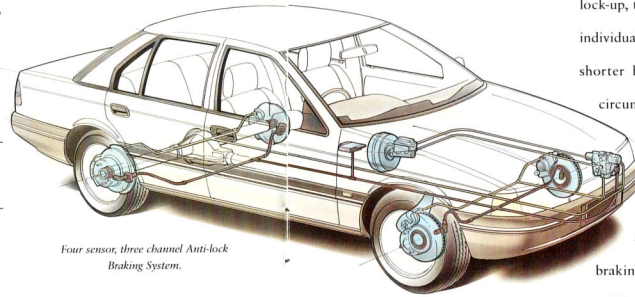

Four sensor, three channel Anti-lock Braking System.

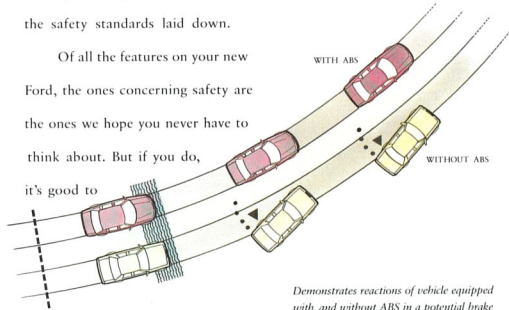

Demonstrates reactions of vehicle equipped with, and without ABS in a potential brake lock-up situation.

A N T I - L O C K  
B R A K I N G  
S Y S T E M .  
I M P R O V E D  
C O N T R O L F O R  
G R E A T E R  
S A F E T Y .

Falcon's optional four sensor, three channel Anti-lock Braking System (ABS) is designed to give you greater control in extreme or emergency braking situations.

To prevent your brakes from locking, sensors at each wheel are connected to a microprocessor which detects when a wheel is about to lock.

When triggered, a system of electronically-controlled valves between the brake booster and the wheel open and close several times per second to enable maximum braking power, just short of

lock-up, to be applied to each wheel individually. Not only does ABS mean shorter braking distances in most circumstances, more importantly it means you still have full steering control so hazards can be more easily avoided by a combination of braking and steering.

The sophisticated ABS fitted as an extra cost option to the new Falcon GLi has software specially programmed for Australian road conditions, including a special 'deep-pulse' program designed for gravel roads. The system is designed to operate with complete effectiveness even when different wheels are on different types of surface; a situation frequently encountered when passing on-coming vehicles on narrow country roads.

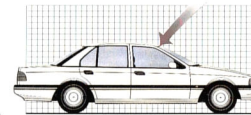

I T ' S T O U G H  
A T T H E T O P .

The passenger safety cage of the new model has been significantly strengthened by improving its roof crush strength and making the roof a

structural member of the passenger compartment.

An epoxy resin composite has been used to reinforce both A and B pillars, while the fitting of thicker front and side glass strengthens the area still further.

Falcon GLi can withstand a force of 32 kN (over 3 tonnes) in testing for the US roof crush resistance standard FMVSS 216.

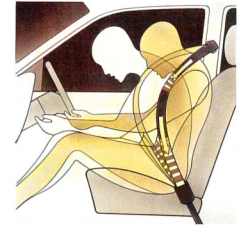

B E L T U P F O R  
S A F E T Y .

Seat belts don't usually rate much attention - until you need them in an emergency. But Falcon's front seat belts are now fitted with a special belt-locking device that instantly stops any payout of seat belt webbing in extreme circumstances. They also have special sections of belt designed with 'popable' stitches to precisely control the movement of the wearer in a collision.



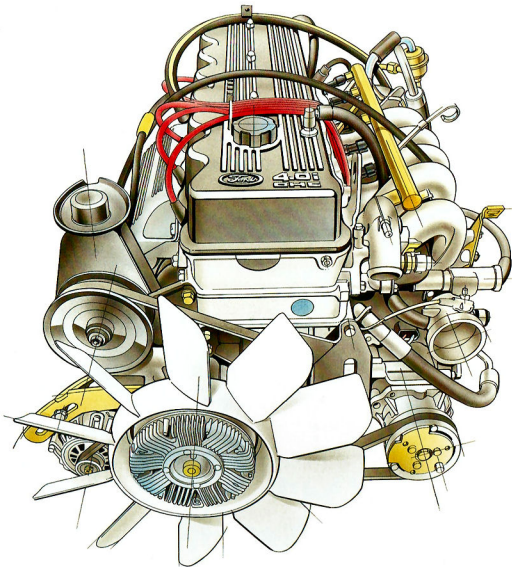

THE POWER ON  
THE MOVE.

Power, and plenty of it, lies at the heart of what makes Falcon GLi such a great family car. And while the performance statistics impress, the fuel efficiency figures will delight anyone with an eye for economy.

Take your choice of either six cylinder or V8 power. Both engines offer copious amounts of energy produced under the economical control of Ford's EEC4 computerised engine management unit.

4 . 0  
MULTI-POINT  
EFI.

Bore & stroke mm	92.26 x 99.3
Cylinder head	OHC Aluminium alloy
Displacement cc	3984
Compression ratio	8.8:1
Fuel injection	Multipoint
Fuel System	Elect. fuel inject. controlled by EEC4 Engine Management System
Fuel	Regular Unleaded
Max Power DIN kW/rpm	148/4500
Max Torque Nm/rpm	348/3750

The new four litre 6 cylinder engine is equipped with an alloy head,

overhead camshaft and multipoint electronic fuel injection. It's designed to produce 148kW of power at 4500 rpm and 348 Nm of torque at 3750 rpm. While this may be the most powerful six cylinder engine ever offered with Falcon, it's the smooth and quiet way in which the power is produced that's so impressive.

That smoothness is the result of a revised combustion chamber plus significant advances in piston and valve technology.

These developments help the engine breathe better resulting in faster, more effective gas flow.

To keep the engine operating at peak efficiency, and with optimum fuel efficiency, Ford's EEC4 Engine Management System incorporates a single highly advanced micro-processor that controls both engine and automatic transmission. This system, known as Integrated Powertrain Control, uses a single chip to reduce electronic complexity and increase reliability. The end result is the co-ordinated monitoring and control of sixteen important engine functions, including fuel air mixture, air intake and coolant temperature, fuel flow and ignition timing.

WHEN THE  
PRIORITY  
IS POWER.

For some situations and for some drivers there is simply no substitute for the uncompromising power of a V8.

And now drivers can once again add V8 performance to the long list of pleasures that come from owning and driving Falcon GLi.

Available as an extra cost option on Falcon GLi automatic only, the 5 litre Falcon V8 engine is the inheritor of a proud tradition of Ford V8s. And this engine is a worthy successor to those illustrious predecessors.

Equipped with Sequential Multipoint electronic fuel injection, the Falcon V8 is designed to developing a stirring 165kW at 4500rpm. With tremendous torque figures of 388Nm at 3000 rpm.

Yet this engine isn't about raw power. It is a product of technical excellence that delivers its energy smoothly and effectively.

Enormous engineering efforts have been poured into making this engine one of the most fuel-efficient V8s ever.

The results will delight even

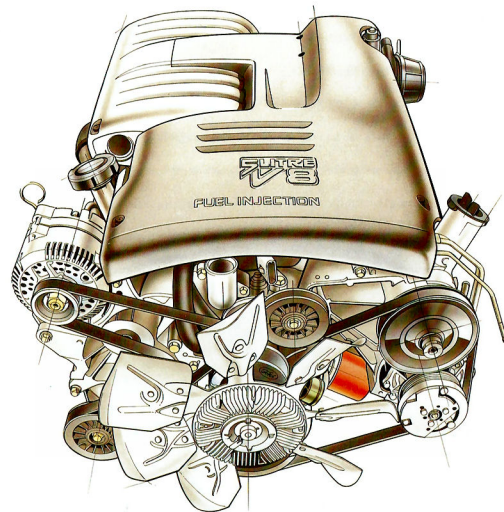

5 . 0 L I T R E V 8 .

Bore & stroke mm	101.6 x 76.2
Cylinder head	Push-rod cast iron
Displacement cc	4942
Compression ratio	9.0:1
Fuel injection	Sequential multipoint
Fuel System	Elect. fuel inject. controlled by EEC4 Engine Management System
Fuel	Regular Unleaded
Max Power DIN kW/rpm	165/4500
Max Torque Nm/rpm	388/3000

those most concerned about fuel consumption.

For efficient breathing, air intake ducts have been specially designed for low restriction. A mass air flow sensor, providing greater

air flow metering accuracy, is monitored by the EEC4 engine management system.

Efficiency is also the watchword for the exhaust system. A semi-dual design is utilised featuring 63mm pipes to reduce back pressure. The system is constructed of long-lasting stainless steel and finishes with the flourish of a chrome plated tailpipe.

No other engine has the ability to seemingly shorten distances, flatten hills or make light work of a tow load like a V8. And no other car combines V8 performance with style and comfort like Falcon GLi.



ADVANCED  
FOUR-SPEED  
ELECTRONIC  
AUTOMATIC  
TRANSMISSION.

Falcon puts its power to work through a smooth and positive feeling five-speed manual gearbox. For drivers who prefer an automatic transmission Falcon's advanced, electronically controlled four-speed transmission is an extra cost option.

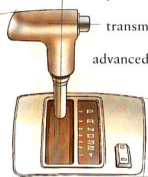

This silky smooth electronic transmission, designed, developed and produced in Australia, gives outstanding fuel economy with quiet operation.

Economy features include a power/economy switch changeable by the driver to suit driving conditions and a torque convertor with 'lock-up clutch'.

STRAIGHT AND  
SMOOTH.

The latest Falcon GLi is equipped with a refined steering and suspension system that give it both a comfortable ride and handling characteristics that inspire confidence.

Up front there's a short and long arm, long spindle (SLALS) front suspension. A sophisticated system built for strength and durability, yet one that offers smooth and confident road holding.

Falcon sedan is fitted with a trusted and reliable Watts Link rear suspension that produces precise and predictable road manners and outstanding stability whilst towing. Falcon wagon retains the proven Hotchkiss rear suspension designed to cope with the extra loads to which a wagon is subjected.

Both sedans and wagons feature suspensions with carefully chosen spring rates and nitrogen-charged gas shock absorbers. In addition, upper and lower rear suspension bushes and mountings are designed to contribute towards a smooth ride and a quiet, durable suspension.

Falcon GLi's power-assisted rack and pinion steering offers excellent 'feel' and sharp responses thanks to carefully selected camber and castor geometry and a quick 18.5 to 1 steering ratio.

Falcon GLi also offers the security and stopping power of

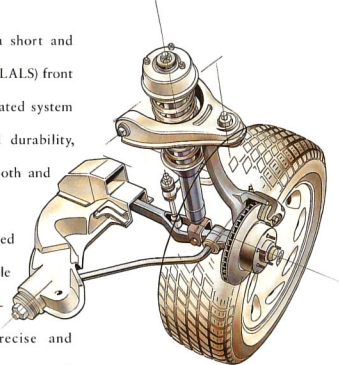

power-assisted four-wheel disc brakes.

Today's Falcon is truly a delight to handle, be it on gravel roads, open freeways, or tight and twisty city conditions.

ON THE  
OUTSIDE.

The sweeping lines of Falcon's exterior brilliantly combine both engineering excellence and distinctive style. So the twin dictates of fashion and function are both superbly accommodated.

Falcon's designers, using the latest in CAD/CAM technology, shaped a car that not only has attractive looks but is also aerodynamically smooth to help increase fuel economy and reduce wind noise.

Falcon's sleek lines are further

improved by flush glass mounting of all windows, by concealed drip rails and exhaust air vents. Special attention has been paid to reducing interior noise, so front and side glass is thicker. Windscreen wipers have been lowered to operate with greater quietness and efficiency. And new mouldings and seals in the body and doors also help keep noise outside.

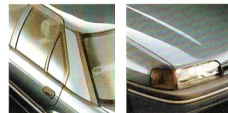

To pack plenty of luggage, the boot has 453 litres of usable carrying capacity while the jack and wheel-brace are tucked away neatly out of sight.

Other important exterior

design features include a low profile bonnet fitted with dual gas struts for ease of opening and closing, one piece body sides to reduce joins and one piece door construction for continuous sealing against dust and water. A wide body side moulding protects Falcon's body and at road level, stylish covers enhance the looks of your wheels.



THE FINISH  
IS BRILLIANT.

To top off such a great body, five separate coating processes are applied to the Falcon GLi.

The entire body is electrochemically cleaned and prepared for painting. The vehicle is dipped in primer, then a second primer coat is applied robotically. Both the topcoat enamel and the clearcoat are applied by robot to ensure the most effective

coverage. Finally, a rust-proofing wax is applied. And for the finest finish of all, prestige paint treatments are available as extra cost options.

Your Falcon GLi's paintwork

does more than just look good. It also protects your investment. In fact it does such a good job Ford provides a five year warranty against perforation corrosion.

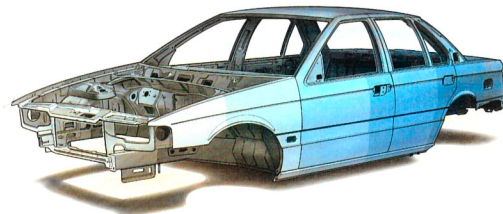



T H E W A G O N ' S  
R O L E .

For some people only a wagon has sufficient space for their needs. And Falcon GLi wagon gives them vast cargo room without having to compromise on comfort.



With ample room for five passengers, or six with the optional Centafold front bench seat, plus 1466 litres of load space, this is a truly comfortable and accommodating wagon. But there's more to come.

The rear seat features a 60/40 split backrest. Fold down either side and increase your cargo area but still be able to carry one or two rear seat passengers. Fold down both sides and you'll open up an awesome 2622 litres cargo capacity.

Loading and carrying are made easy thanks to a high and wide opening tailgate and a virtually flat floor with no intruding suspension towers. For a clear view behind, Falcon GLi has a tailgate wiper/washer. When the front wipers are in use and reverse gear is selected, the rear wiper is automatically activated.

The latest Falcon wagon also makes the powerful option of Ford's V8 engine available, at extra cost. Further proof that with Falcon GLi wagon, wagon drivers travel first class.



**CONSIDER  
YOUR OPTIONS.**

Further increase the level of comfort, performance or style of your Falcon by adding from this list of extra cost options.

**5 LITRE  
SEQUENTIAL  
MULTIPOINT  
EFI V8 ENGINE.**

The ultimate in power and performance - V8 power is once again available for Falcons. This five litre V8 is equipped with a sequential multipoint electronic fuel injection system and is designed to produce

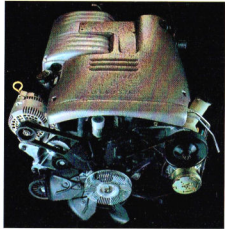

165kW of power at 4500 rpm. Its torque figures are equally impressive, being able to generate 388Nm of torque at 3000 rpm. The enormous energy of this sophisticated power plant makes the Ford V8 the engine of choice for extra performance and long distance towing power.

**ELECTRONIC  
AUTOMATIC  
TRANSMISSION.**

Superbly smooth in operation, Ford's automatic 4-speed transmission offers advanced electronic control.

Designed, developed and is built in Australia for our road conditions. Choose from a 4-speed T-bar or a 4-speed column change with the 'Centafold' seat option. This electronic transmission includes a power/economy switch, which alters the gearbox shift pattern to best suit the prevailing driving conditions.

**AIR  
CONDITIONING.**

Factory fitted integrated air conditioning brings relief from the heat and humidity of Australia's harsh climate. It also provides fast, efficient demisting.



*Eye catching sports-styled alloy wheels.*

**LIMITED SLIP  
DIFFERENTIAL.**

Provides improved traction in wet or slippery conditions.

Recommended for cars used for towing or travel on unsealed roads.

**TOWING PACK.**

Specially designed for Ford Falcon, the tow pack offers a towing capacity of 1200kg. Including a tow bar with painted gooseneck, wiring harness, 7-pin connector and reinforcement brackets.

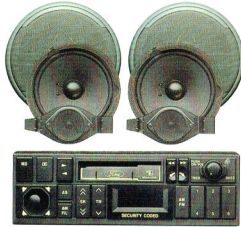

**DELUXE SOUND  
SYSTEM.**

For entertainment on the move. Featuring a sophisticated Clarion AM/FM stereo radio cassette with Dolby tape hiss reduction, music search, auto scan, memory storage, security coding, auto store and joystick fader/balance control. Eight individual speaker elements combine to produce high fidelity sound.



**CENTAFOLD  
SEAT.**

A unique Ford Falcon option, 'Centafold' is available as an alternative to standard bucket seats. Lift the armrest and it becomes a backrest and creates front seating for three. Four-speed column shift automatic is mandatory with the Centafold option.

**HEAVY DUTY  
SUSPENSION.**

Heavy duty springs and shock absorbers produce a 19mm increase in ground clearance of underbody components.



For increased suspension life under rigorous operating conditions such as country travelling, this is an intelligent addition to your new Falcon's equipment list.

**CAR  
ALARM.**

Sophisticated and highly sensitive alarm system designed to protect your new Ford GLI. Features include remote active arming, auto arming selectable, auto disarming, rearming if no entry after 60 seconds, starter cut out, shock detector, L.E.D. display. Remote control of the central locking system is also included.

**CRUISE CONTROL.**  
This convenient option maintains a constant speed on the open road. Instantly disengages when either brakes or 'off' switch are operated. Switches for cruise Control are integrated into the steering wheel hub for increased safety and convenience.

**SPECIAL  
EXTERIOR PAINT.**  
For a finishing touch of class, choose from the impressive list of prestige paints.

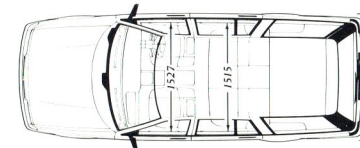
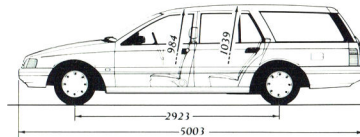
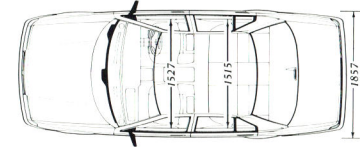

*All dimensions are shown in (mm).*

STYLING  
AND  
SUSPENSION  
OPTIONS.

Your new Falcon sedan is engineered to perform to exacting standards of ride and road holding. But for the driver who wants to equip his new car to perform with even sharper handling and quicker responses, specialised suspension option packs are available to enhance your Falcon sedan's capabilities.

Ford option packs are specifically made for Ford vehicles from high quality materials. They're installed when your new car is being built, so you are assured of proper fit and compatibility. Ford option packs are fully covered by the Ford Express New Vehicle Warranty.

FORD HANDLING  
OPTIONS GIVE  
YOU EVEN  
BETTER  
PERFORMANCE.  
Australia's motoring press have praised the handling of the new Falcon. With Sports Pack 1, that handling is improved even further.

Stiffer front and rear springs, new sports-tuned shock absorbers and bushes, new front stabiliser bar and revised wheel alignment combine to produce razor-sharp handling and a new low stance on the road.

SPORTS PACK 2.  
All the features of Sports Pack 1 plus Italian 'MOMO' leatherbound

four spoke sports steering wheel. Adds an extra touch of class and improves steering feel.

SPORTS PACK 3.  
All the features of Sports Pack 2 plus body styling package.

Includes side skirts, front and rear spoilers and rear apron.

Improves aerodynamic performance and gives head-turning looks to your new Falcon.

16" WHEELS  
AND TYRES.

Aggressive 16" x 7" five spoke alloy wheels fitted with high performance Michelin 225/50 ZR16 tyres. Designed to fully exploit the handling capabilities of Sports

Packs, while adding a bold new style to your vehicle.

CLASS II  
TOW PACK.  
2100kg rated capacity. Features Hayman Reese towbar and hitch, trailer wiring kit, revised turn signal flasher, brake pads and oil cooler.

SUNROOF.  
Precision crafted electric glass sunroof full imported from Germany.

Operates as a tilted vent to improve ventilation or partially or fully open to increase your enjoyment of the great outdoors. Automatic pop-up wind deflector reduces wind noise and buffering.

Falcon GLi shown equipped with Sports Pack 3 and 16" wheels and tyres.

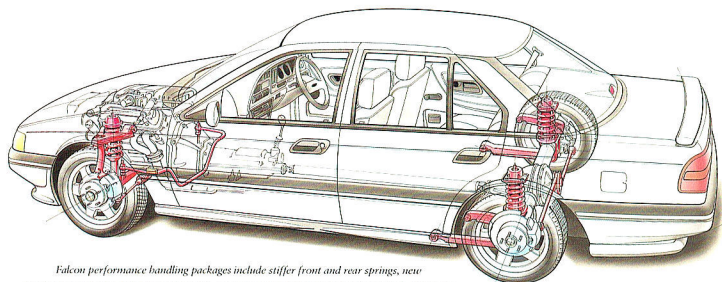

Falcon performance handling packages include stiffer front and rear springs, new sports-tuned shock absorbers and bushes, new front stabiliser bar and revised wheel alignment.

EXTRA  
PERFORMANCE.  
EXTRA  
PLEASURE. NO  
EXTRA WORRIES.  
Fitting any of these options to your new Ford will enhance your enjoyment of your new car and add to its value. Whether you choose to specify one of the Sports Packs, Touring Packs, Sunroof, Tow pack or 16" wheels, the warranty cover of your new Ford is not affected in any way. You'll still receive all the benefits of Fordcare and the options themselves are fully covered by the Ford Express New Vehicle Warranty.

A COMPREHENSIVE  
RANGE OF  
ACCESSORIES.

Make your Falcon as individual as you are with a selection of Ford approved accessories. Choosing the accessories you want will help make your Falcon even more enjoyable,

enhance its styling, help protect its bodywork and add value.

Ford factory accessories are the only accessories specifically designed for Falcon. They're manufactured with the same care and attention to quality as the car itself, and are fully covered by the Ford

dealer 12 month/20,000km express parts warranty.

Choose your accessories when you buy your new Falcon and start enjoying the advantages they offer right from the start.

Your Ford dealer will be happy to show you the range.



What the best dressed Falcons are wearing. Shown (front view) sun visor, headlamp guards, weathershield, bonnet protector, carry bars, styled mud flaps.



Shown (rear view) rear sunshade, chrome exhaust extension, styled mud flaps.

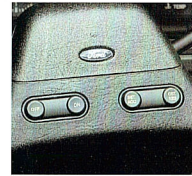

Cruise Control. Helps maintain a constant speed on the open road. Instantly disengages when brakes or clutch are operated. (6 cyl. MPi EFI only)

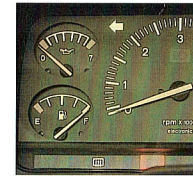

Sports instrumentation. Includes tachometer, ammeter and oil pressure gauge.



Trip computer. Displays fuel consumption, distance to empty and average speed.



Carpeted door bins. Extra, useful storage space, trimmed to colour co-ordinate.



Rear louvre. Helps reduce glare and shades rear seat occupants.



Weathershields. Tough acrylic shields which help protect against wind and light rain.



Tirebar (Class 1) Specially designed for Falcon. Tows up to 1200kg. Meets Australian Design Rule (ADR4-1) specifications.



Styled mud flaps. Enhance your Falcon's looks and help protect against stones and grime.

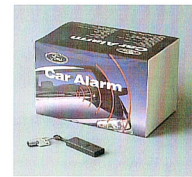

The only car alarm approved by Ford. Can be tailored to provide different levels of protection. Features both audible and visual alarms.



Remote central locking conversion kit. Converts standard central locking to remote control operation.

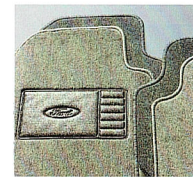

Tailored carpet mats. Hard wearing protection, in two colours to match your Falcon's interior.



Car care products. A range of quality products to help maintain your Falcon's appearance inside and out.

**OTHER**

**ACCESSORIES**

**AVAILABLE**

**INCLUDE:**

**FORD SELECTAIRE**

**AIR CONDITIONING**

Efficient air conditioning offers cool comfort on hot days and de-humidified air for de-misting in cold and damp conditions.

**SUN VISOR**

A stylish accessory and offers practical protection from sun and glare.

**REAR SUNSHADE-TWIN BLADE**

An attractive alternative to the rear louvre for rear seat sun protection.

**REAR VENETIAN SHADES**

Helps protect rear seat passengers and interior from the sun.

**WAGON ROOF RACK**

Carry up to 90kg of additional baggage.

**INSECT SCREEN**

Helps keep bugs out of radiator. Easily removed for cleaning.

**TIRRE LOCK SWITCH KIT**

Dash mounted switch allows drivers to lock/unlock all doors from the driver's seat.

**AIR HORNS**

Give a penetrating dual tone.

**WAGON VENETIANS**

Helps provide extra shade when fitted to tailgate and rear side glass.

**REAR SUNSHADE-SINGLE BLADE**

Made of dark grey translucent acrylic. Offers style and practicality.

**ELECTRIC AERIAL**

Raise or lower the aerial from inside the vehicle.

**60 WATT REAR SPEAKERS**

For superb all-round sound when combined with standard front speakers.

**HEADLAMP GUARDS**

Help protect headlamps from chipping and breakage.

**BONNET PROTECTOR**

Helps protect your paintwork from stone chips and minor scratching.

**SUMP GUARD**

Extra protection for the underside of your Falcon in rough conditions.

**WAGON DUST DEFLECTOR**

Helps avoid dust and dirt build up on rear windows

(Painting optional at extra cost.)

**FIRE EXTINGUISHER**

An important safety accessory. Supply with mounting bracket.

**LOCKING FUEL CAP**

Helps guard fuel against theft or tampering.

**TRAILER WIRING/ACCESSORIES**

Everything you need to connect Falcon's electrical system to a caravan or trailer.

**CARRY BARS**

Easily fitted to wagon or sedan. Ideal for skis or surfboards.

**AIR ADJUSTABLE SHOCK ABSORBERS**

Help maintain a level ride when carrying extra heavy loads or when towing.

**TRANSMISSION OIL COOLER**

Helps avoid overheating and possible transmission damage. Essential for towing with auto transmission

**BODY STYLING PACKAGE**

Extra style - ask your Ford dealer about the exciting and attractive

Ford-approved body styling packages available for Falcon sedan and wagon.

**CHROME EXHAUST EXTENSION**

Adds a finishing touch.

**FORDCARE.**

**OUR COMMITMENT TO**

**CUSTOMER SATISFACTION.**

We are committed to ensure that you enjoy your new Ford from delivery, through all of its lifetime. We meet that commitment with Fordcare - a range of services and benefits designed for Ford vehicles and their drivers.

At the frontline of Fordcare are highly trained technicians backed by advanced equipment and parts support.

■ Sophisticated diagnostic, tuning and servicing equipment.

■ Oasis (On-line Automotive Service Information System), an extensive Ford Engineering data base that helps technicians pinpoint problems quickly and helps save you money - available at most Ford dealers.

■ Ford Approved Service Parts - the ones you can trust to perform like original equipment - are covered by the Ford dealer 12 month/20,000 kilometre Express Parts Warranty for your protection.

You can relax knowing that Fordcare will always be there to help keep your vehicle at the peak of performance.

The in-built quality of your Ford is backed by the following additional warranties.

**12/20 EXPRESS**

**FORD VEHICLE WARRANTY.**

Covers your Ford against defects in materials or workmanship for the first twelve months or 20,000 km - whichever comes first.

**FIVE YEAR PERFORATION CORROSION WARRANTY.**

Covers the original vehicles' body against perforation corrosion for the first five years of its life.

**LIFETIME SERVICE**

**WARRANTY.**



Covers the majority of part replacements, including labour carried out by your Ford dealer after the expiration of the initial 12 month/20,000km warranty. You will only ever pay once for such replacements.

**LIFELONG PANEL**

**WARRANTY.**



Covers replacement outer body panels against perforation corrosion for the life of the vehicle.

Further information on these warranties may be obtained from your Ford dealer.

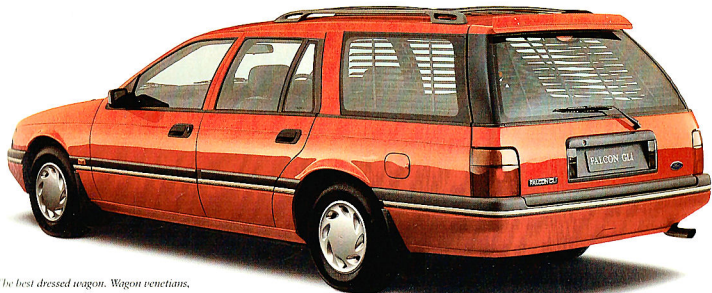

The best dressed wagon. Wagon venetians, wagon roof rack, wagon dust deflector, styled mud flaps.

## FORDcare

All Ford vehicles sold throughout Australia are backed by Fordcare after sales service.

Fordcare is comprised of a number of individual service products designed exclusively for Ford vehicles and their drivers. These include technical support back-up, diagnostic equipment, approved Ford/ Motorcraft replacement parts and service warranties.

This brochure is designed to provide you with a general introduction to the Ford Products (including available optional equipment) referred to, and should be read in conjunction with the latest specification sheet. Because of changes in conditions and circumstances Ford<sup>®</sup> reserves the right, subject to all applicable laws, at any time, at its discretion, and without notice, to discontinue or change the features, designs, materials, colours and other specifications and the prices of its products, and to either permanently or temporarily withdraw any such products from the market without incurring any liability to any prospective purchaser or purchaser. The latest specification sheet should be referred to for information on the availability, ordering and use of optional equipment. Always consult an Authorised Ford Dealer for the latest information with respect to features, specifications, prices, optional equipment and availability before deciding to place an order.

FORD MOTOR COMPANY OF AUSTRALIA LIMITED.  
A.C.N. 004 116 223. Registered Office: 1735 Sydney Road,  
Campbellfield, Victoria 3061, Australia. Printed February 1992.



**HAVE YOU DRIVEN A FORD...LATELY?**



# FORD FALCON GLi

## FORDcare

All Ford vehicles sold throughout Australia are backed by Fordcare after sales service.

Fordcare is comprised of a number of individual service products designed exclusively for Ford vehicles and their drivers. These include technical support back-up, diagnostic equipment, approved Ford/ Motorcraft replacement parts and service warranties.

This brochure is designed to provide you with a general introduction to the Ford Products (including available optional equipment) referred to, and should be read in conjunction with the latest specification sheet. Because of changes in conditions and circumstances Ford\* reserves the right, subject to all applicable laws, at any time, at its discretion, and without notice, to discontinue or change the features, designs, materials, colours and other specifications and the prices of its products, and to either permanently or temporarily withdraw any such products from the market without incurring any liability to any prospective purchaser or purchaser. The latest specification sheet should be referred to for information on the availability, ordering and use of optional equipment. Always consult an Authorised Ford Dealer for the latest information with respect to features, specifications, prices, optional equipment and availability before deciding to place an order.

\*FORD MOTOR COMPANY OF AUSTRALIA LIMITED.  
A.C.N. 004 116 223. Registered Office: 1735 Sydney Road,  
Campbellfield, Victoria 3061, Australia. Printed February 1992.



**HAVE YOU DRIVEN A FORD...LATELY?**



**HAVE YOU DRIVEN A FORD...LATELY?**

