



2007 **FORD** LCF



2007 FORD LCF LOAD WARRIOR

The class-leading maneuverability and capability of Ford LCF cuts big cargo down to size. Its 4.5L Power Stroke® V6 Turbo Diesel tops the segment in horsepower and torque. Innovative design delivers a best-in-class* turning radius. And of course, it's Built Ford Tough, with the strongest standard frame and class-exclusive Huck Bolt™ construction for outstanding frame integrity and longevity. Conquer tight city streets with agility and efficiency. And do it in style, in your choice of 9 vibrant exterior colors – no extra charge. When your challenges are bigger than ever, Ford LCF is reporting for duty.

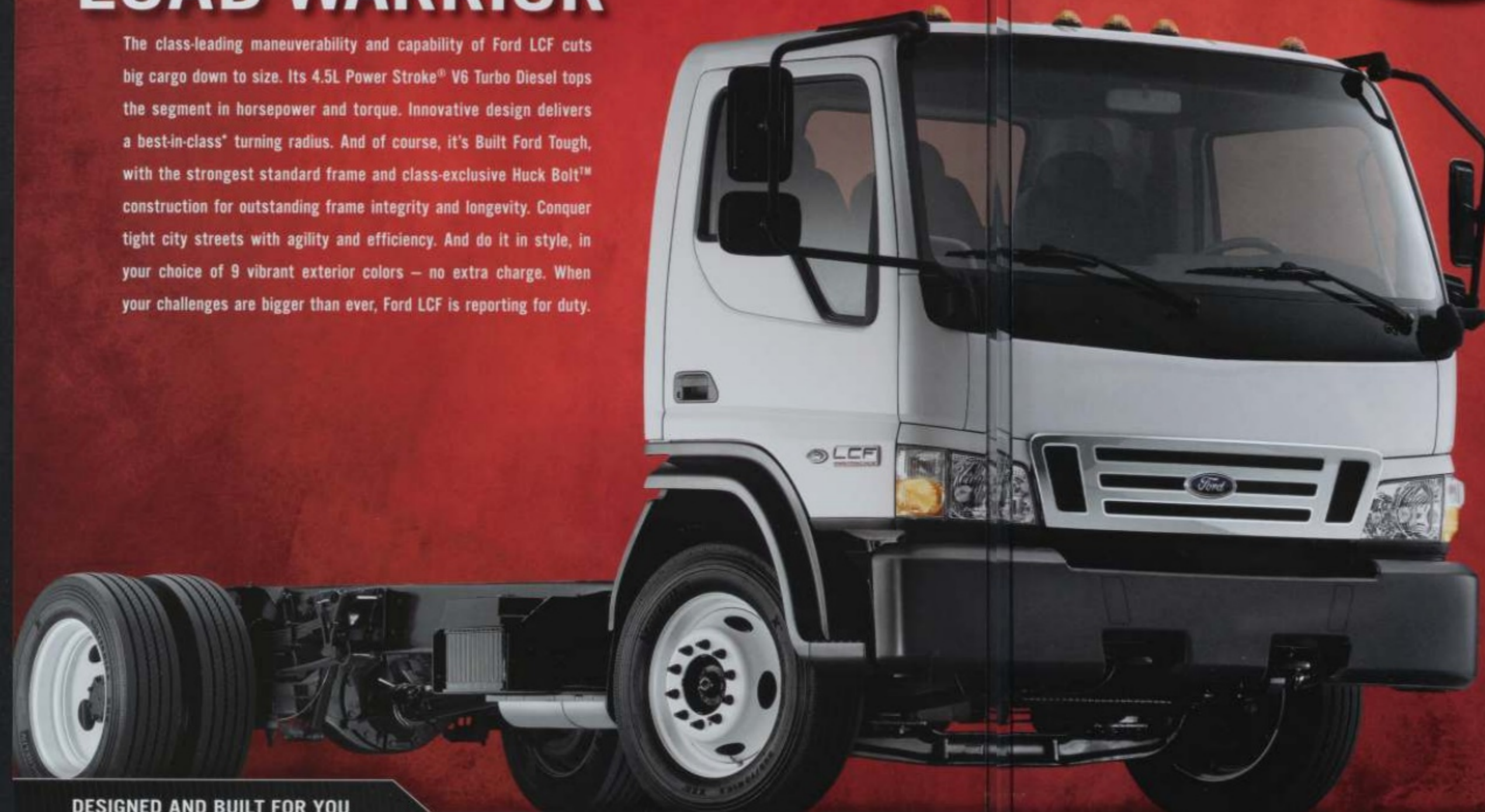

BEST-IN-CLASS TURNING RADIUS

- 16'5" curb-to-curb
- 18'4" wall-to-wall
- 53° wheel cuts

BEST-IN-CLASS POWER AND TORQUE

- 4.5L Power Stroke V6 Turbo Diesel
 - 200 horsepower
 - 440 lb.-ft. of torque
 - 2 million miles of testing

CAPABLE WORK TRUCKS

- 4 GVWR offerings: 15,000 and 16,000 lbs. (L45); 17,999 and 19,500 lbs. (L55)
- Strongest standard frame (RBM)
- 4-wheel disc brakes with ABS
- Exclusive Huck Bolt frame construction
 - 19.5" wheels and tires

NO-CHARGE EXTRAS

- 9 exterior color choices
- Standard power windows and door locks
- Standard cloth interior trim

DESIGNED AND BUILT FOR YOU

The 2007 Ford LCF is made **SPECIFICALLY FOR THIS MARKET**. It's just one of the advantages this Built Ford Tough truck offers over the competition. Want another? The chassis on the Ford LCF shares many key components with our proven Super Duty® models. Most importantly, the Ford LCF was engineered, tested and put through its paces here. And it's assembled nearby, so it isn't shipped from overseas. All of which means that we can deliver the right vehicle to meet your company's needs, right when you need it. You get **QUICK TURNAROUND ON SPECIAL ORDERS**, a feature that competitors who build and customize offshore can't offer. We even cover you with 24-hour turnaround on up-time critical parts, as well as a unique Limited Warranty** through our Ford LCF-Certified Truck Dealers.

*Class 4 Tilt-Cab Diesels, excluding Ford joint-venture partners. **See your dealer for details.



CHASSIS

	WHEELBASE (WB) (in.)	AXLE-TO-FRAME (AF) (in.)	CAB-TO-AXLE (CA) (in.)	OVERALL LENGTH (OL) (in.)
CLASS 4 MODEL:	113	47.5	84	204.7
L45	113	63	84	220.2
FRAME RATING:	137	47.5	108	228.7
50,000 PSI	137	63	108	244.2
	149	47.5	120	240.7
RBM:	149	75	120	268.2
461,000 IN.-LBS.	167	75	138	286.2
CLASS 5 MODEL:	113	47.5	84	204.7
L55	113	63	84	220.2
FRAME RATING:	137	47.5	108	228.7
50,000 PSI	137	63	108	244.2
	149	47.5	120	240.7
RBM:	149	75	120	268.2
461,000 IN.-LBS.	167	75	138	286.2
	185	96	156	325.2

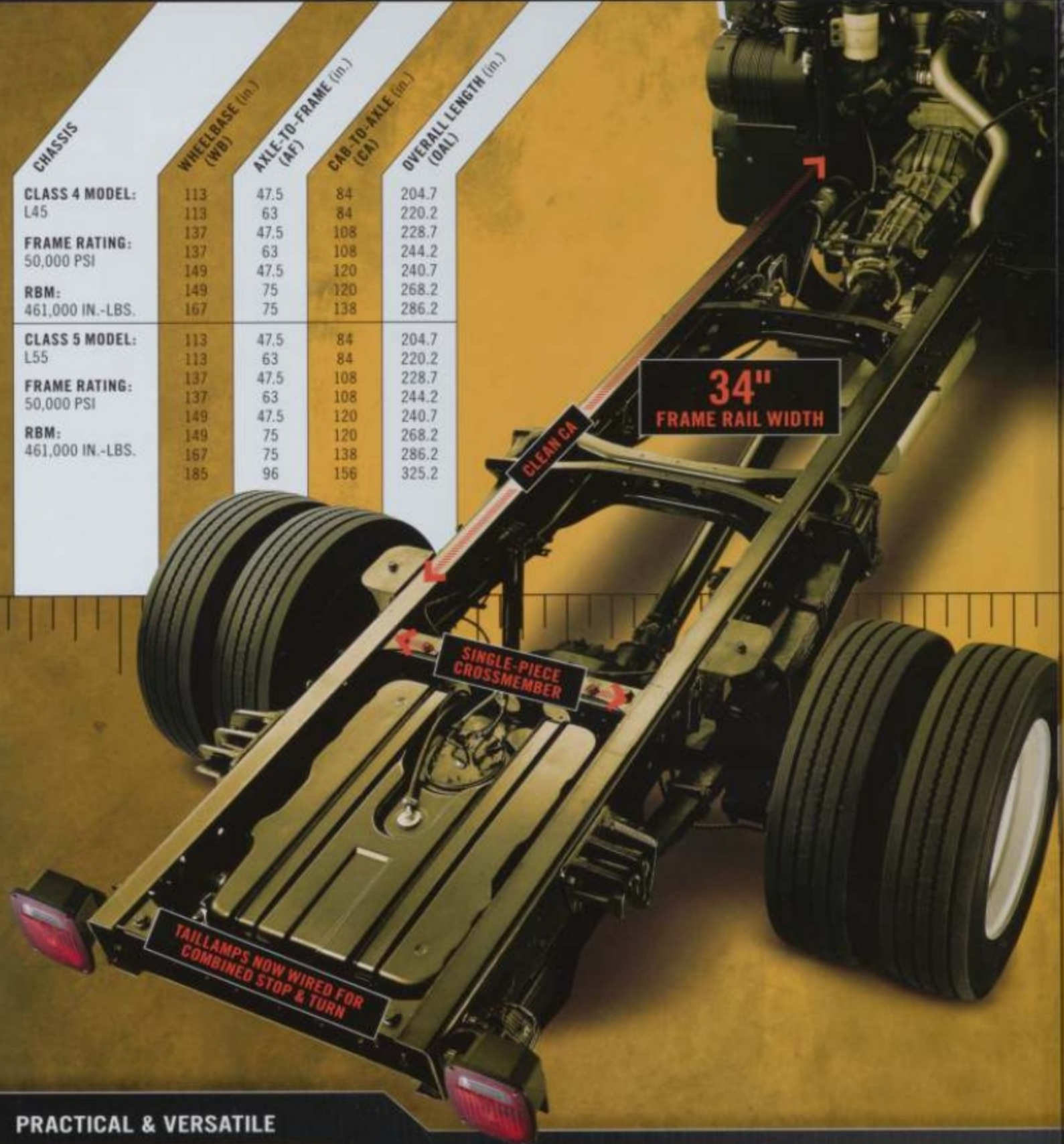

**34"
FRAME RAIL WIDTH**

**SINGLE-PIECE
CROSSMEMBER**

**TAILLAMPS NOW WIRED FOR
COMBINED STOP & TURN**

PRACTICAL & VERSATILE



The low 30" ground-to-top-of-frame height of the Ford LCF **STANDARD KICKUP FRAME** is ideally suited to applications that require a low, flat loadfloor without interior encroachment. Every Ford LCF also features a **34" FRAME RAIL WIDTH** to facilitate upfits. Several **FUEL TANK OPTIONS** include the standard **40-GALLON TANK** mounted aft-of-axle for balanced weight distribution, or an available **35-GALLON TANK** mounted outside the frame rails on the left. If your upfit dictates, or you need maximum fuel range, opt for **TWO 35-GALLON TANKS**, one mounted on either side of the vehicle. The Ford LCF also features **2 MAINTENANCE-FREE BATTERIES** conveniently mounted in a box outside the frame rails on the right.



www.commtruck.ford.com

Ford LCF is the only vehicle in the segment* to use the **MASSIVE STRENGTH OF HUCK BOLTS™** to join all non-serviceable frame components. This Class 8 frame technology permanently locks frame components in place, while delivering rigidity and longevity superior to that of rivet-fastening systems used by other truck makers.

*Class 4 Tilt-Cab Diesels, excluding Ford joint-venture partners.



**EXCLUSIVE HUCK BOLT
CONSTRUCTION
(ACTUAL SIZE)**

ENDLESS POSSIBILITIES

These words may strike fear in the hearts of some, but here they represent your opportunity to build the Ford LCF that fits your business best. Choose from a vast array of compatible upfit bodies and equipment that fit easily on 5 different clean CA (cab-to-axle) measurements. And while some competitors' specs imply that you have more space than you can use, our numbers represent a truly clean, usable part of the frame. So consider the possibilities, and imagine the many ways that your business can benefit from the versatility of the Ford LCF.



TOP-GRADE COMPONENTS

When your business is on the line and you're dealing with serious payloads, you need a truck that **PERFORMS AT ITS BEST – STOPPING AND GOING**. That's why every Ford LCF features fully hydraulic 4-wheel disc brakes with an Anti-lock Brake System (ABS) as standard equipment. You don't have to settle for the Class 4 competitors that use 16" wheels and a narrower track. Ford LCF features standard 19.5" wheels and a wide track (73.4" front/74.0" rear) to help provide a **STABLE FOUNDATION**.



AN IMPRESSIVE SHOW OF FORCE



Ford LCF's class-leading* horsepower and torque score big when you have cargo to move and work to do. Fire up the standard 4.5L Power Stroke® V6 Turbo Diesel and serious muscle is at your command. This durable engine is combined with our proven TorqShift™ 5-speed automatic transmission. Boasting maximum power, reliability and efficiency, Ford LCF puts you ahead of the game.

*Class 4 Tilt-Cab Diesels, excluding Ford joint-venture partners.

4.5L POWER STROKE V6 TURBO DIESEL

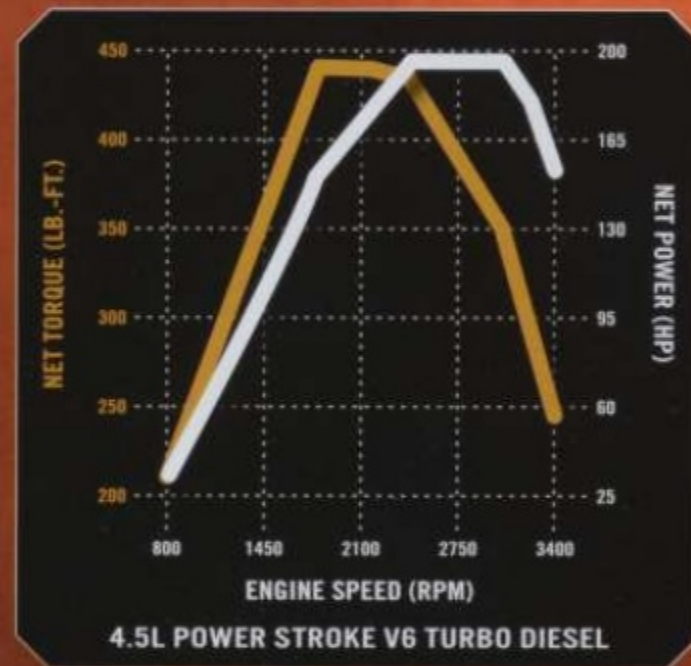

HORSEPOWER	200 @ 2650
TORQUE (LB.-FT.)	440 @ 1850
COMPRESSION RATIO	18.0:1

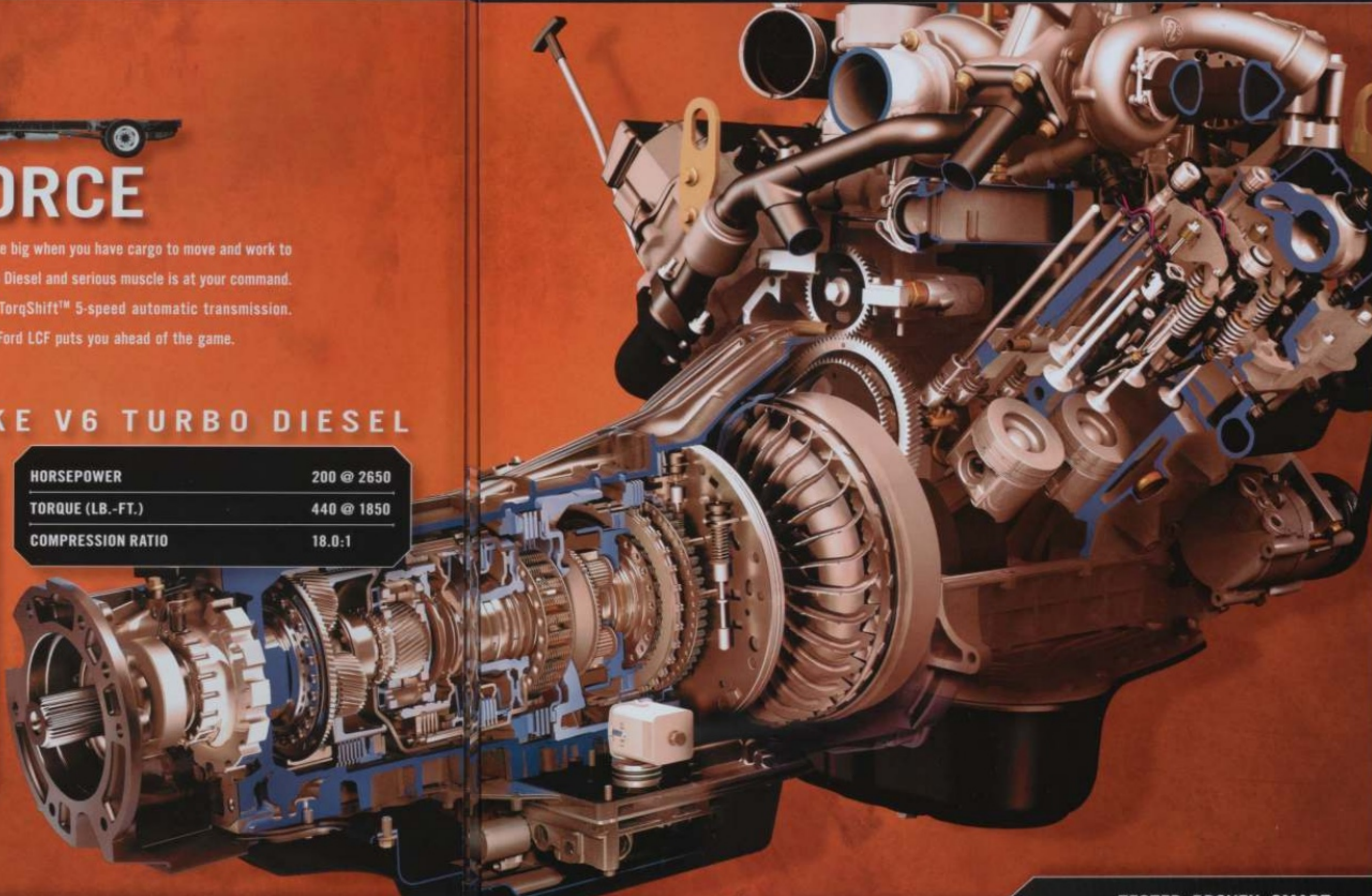

RUGGED DRIVELINE

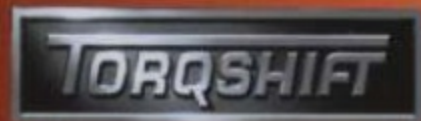

Standard on every Ford LCF, the proven TorqShift 5-speed automatic transmission features pure **ELECTRONIC SHIFT CONTROLS** for optimum responsiveness and a torque converter designed for enhanced low-speed capability. Its high-capacity pump design results in increased lubrication and better cooling, while precision materials help enhance overall durability. For ease of service, the spin-on transmission oil filter is externally mounted. Select **TOW/HAUL MODE** when hauling a heavy load or trailer. It helps reduce gear hunting, improves power delivery, and even uses engine braking to help control vehicle speed when descending hills. The available transmission-integrated **PTO (POWER TAKEOFF)** provision [Order Code 44B] is essential for powering accessories like liftgates, skylifts, auxiliary hydraulic pumps and other add-on equipment.



www.commtruck.ford.com

TESTED, PROVEN, SMART



In addition to producing class-leading horsepower and torque, the 4.5L Power Stroke is built to stand the test of time. After being subjected to **OVER 2 MILLION MILES OF EXTREME TESTING** – from inner-city congestion to desert heat to high elevations – it emerged with a projected B10 life of 250,000 miles. The only V6 available in the segment, it features a **DUAL-TURBO DESIGN** for quick engine response around town and out on the highway. Derived from Ford's renowned 6.0L Power Stroke V8 Turbo Diesel, this engine also helps make Ford LCF easy to service. For instance, the **OIL AND FUEL FILTERS ARE MOUNTED ON TOP** of the engine [right], so they're readily accessible. And since these same filters and many major components are interchangeable with its V8 cousin, you'll also benefit from **QUICK PARTS AVAILABILITY**.

WEIGHT LIMITS

MODEL LINEUP		STANDARD	OPTIONAL
L45 – Class 4	GVWR	16,000 lbs.	15,000 lbs.
	FGAWR	6,000 lbs.	7,000 lbs.
	RGAWR	11,000 lbs.	–
L55 – Class 5	GVWR	19,500 lbs.	17,999 lbs.
	FGAWR	7,000 lbs.	–
	RGAWR	13,500 lbs.	–

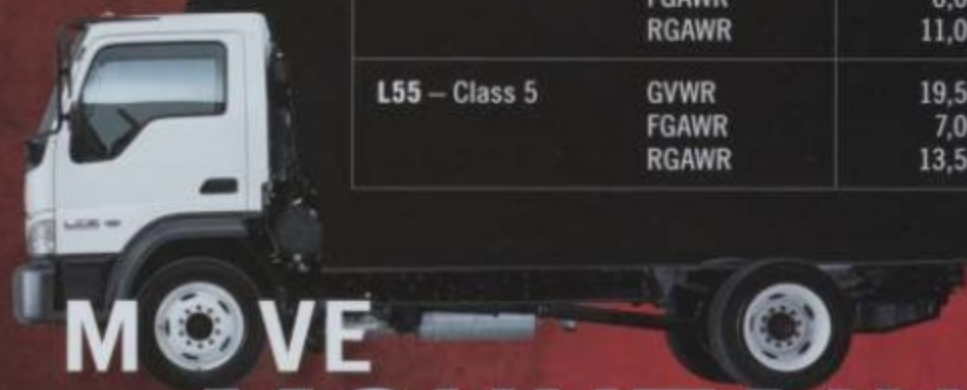

MOVE MOUNTAINS

When your warehouse is stacked to the ceiling, count on the Ford LCF to empty it fast. With the strongest standard frame in its segment, the Ford LCF features available GVWRs from 15,000 to 19,500 lbs., and those numbers mean serious payload power. For confident handling, tapered leaf springs give a softer ride when the load is light, and increase in stiffness as the payload increases. No matter what you're moving, Ford LCF handles tall orders with ease.

STRONG FOUNDATION



The **STRONGEST STANDARD FRAME IN ITS CLASS** boasts a mighty 461,000 RBM (Resisting Bending Moment). The frame begins with rails created from 50,000 psi high-strength steel, and it's completed with **SINGLE-PIECE CROSSMEMBERS** secured by **SEGMENT-EXCLUSIVE HUCK BOLTS™**. It's a solid platform for your choice of a **STANDARD 6000-LB. FRONT AXLE AND 11,000-LB. REAR AXLE ON L45**, or a **STANDARD 7000-LB. FRONT AXLE AND 13,500-LB. REAR AXLE ON L55**. Standard **AEON AUXILIARY SPRINGS** provide additional support in back for the heaviest loads. As you can see, the frame, driveline and suspension systems are optimized for strength and stability under the most demanding conditions.



www.comtruck.ford.com



BEST-IN-CLASS TURNING RADIUS

WHEELBASE	CURB-TO-CURB	WALL-TO-WALL
113"	16'5"	18'4"
137"	19'3"	21'0"
149"	20'8"	22'5"
167"	22'5"	24'2"
185"	24'6"	26'3"

DIMENSIONS

- A. Bumper to back of cab (BBC) – 63.3"
- B. Bumper to front axle (BA) – 44.2"
- C. Frame to top of cab – 61.9"
- D. Top of cab from ground – 90.2"
- E. Step to ground – 18.0"
- F. Cab sill to ground – 35.1"
- G. Frame height at center line of axle, front (unloaded) – 28.3"
- H. Frame height at center line of axle, rear (unloaded) – 30.0"
- I. Mirror width (center to center) – 115.0"
- J. Bumper width – 82.9"
- K. Fender width – 82.9"
- L. Overall width, front – 87.2"
Overall width, rear – 93.6" (not shown)
- M. Track, front – 73.4"
Track, rear – 74.0" (not shown)
Door opening – 65° (not shown)
Cab-tilt angle – 43° (not shown)

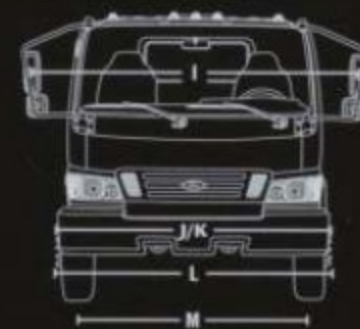
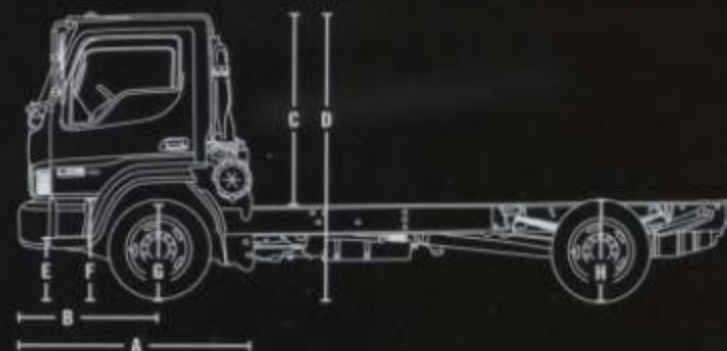

EASYGOING

You'll really appreciate how easy it is to navigate the Ford LCF up to loading docks and around crowded job sites. It's all thanks to the superb maneuverability provided by the segment's **TIGHTEST CURB-TO-CURB** and **WALL-TO-WALL TURNING RADIUS**. The Ford LCF also features a remarkably **SHORT 63.3" BUMPER-TO-BACK-OF-CAB (BBC)** measurement. That's the beauty of the tilt-cab design. The steering system also contributes, with innovative engineering that delivers high-efficiency turn-in. So the Ford LCF makes tight corners and fits into small spaces that leave other trucks double-parked.



GET INTO YOUR COMFORT ZONE

Whether you need room for the occasional passenger or a regular crew, the Ford LCF is built to accommodate. Ample 3-passenger seating comes in comfortable, durable standard cloth trim. There's more than enough head and leg room to satisfy big and tall riders alike. Plus, the well-positioned grab handles and a low first step make entry and exit a breeze. With its thoughtful features and ergonomic design, Ford LCF can help you get the most out of every workday.



Ford LCF shown with available equipment

DRIVER CONVENIENCE



The Ford LCF includes many standard features to help your days run smoother. You can adjust the standard **TILT/TELESCOPING STEERING COLUMN** to your preferred driving position. Smart design and the location of controls maximize your driving comfort. An **OVERHEAD STORAGE AREA WITH 2 STORAGE BINS, 3 GLOVE COMPARTMENTS** in the instrument panel, and a **MAP POCKET** in each door provide handy storage. We even included **2 CUPHOLDERS** that store in the instrument panel when not in use.



www.commtruck.ford.com

INTERIOR AMENITIES



Driver comfort is high on your list of priorities – as it should be. And the Ford LCF is already equipped to make your workdays a little more enjoyable. Standard features include **CLOTH SEATING** in Flint Grey, **POWER DOOR LOCKS**, and **POWER WINDOWS** with a driver's-side one-touch-down feature. For added comfort and security, order the available **AIR CONDITIONING** with integral heater/defroster, and **REMOTE KEYLESS-ENTRY SYSTEM** with panic alarm and audible lock confirmation.



WITH YOU ALL THE WAY

When you're in charge, it's a 24/7 commitment — there's no quitting time. So you need dependable, reliable equipment you can trust to keep up the pace. Look no further than Ford LCF. Designed and Built Ford Tough, the Ford LCF is backed by our extensive network of over 700 Ford LCF-Certified Truck Dealers. They'll help keep your trucks and business rolling with certified mechanics and ready access to up-time critical parts, which adds up to less downtime and more productivity for you and your bottom line.

BUSINESS PREFERRED NETWORK/ LIMITED WARRANTY



Each of the select dealerships in our **BUSINESS PREFERRED NETWORK (BPN)** is committed to providing you and your business with quality commercial-oriented products and service — as well as special financing and billing arrangements. As a BPN customer, your business vehicles receive priority service at your BPN dealership to help get them back on the road quickly.

The Ford LCF **LIMITED WARRANTY** provides 2-year/unlimited-miles coverage on the cab/chassis, 3-year/unlimited-miles coverage on the 4.5L Power Stroke® V6 Turbo Diesel and 5-speed TorqShift™ automatic transmission, 4-year/unlimited-miles coverage against corrosion-perforation, and 5-year/unlimited-miles coverage on frame rails. Ask your Ford LCF-Certified Truck Dealer for complete details.



www.commtruck.ford.com

EXTENDED SERVICE PLAN/ FINANCIAL SERVICES



Whether you plan to purchase or lease, the Ford **EXTENDED SERVICE PLAN (ESP)** gives you extra peace of mind. It's designed to protect you from the cost of unexpected repairs by covering key vehicle components. Be sure to ask your dealer for an ESP, the only service contract backed exclusively by Ford and honored at all LCF-Certified Ford dealerships. Our commercial

purchase plans and lines of credit offer attractive rates, negotiable terms and business-friendly options. If you prefer to lease, our CommercialLease™ programs offer a wide variety of package options to meet your needs. For additional information please visit our website at www.fordcredit.com/comlend/.

STANDARD EQUIPMENT

MECHANICAL

Air cleaner — Single-element with Filter Minder® indicator
 Alternator — 12-volt, 135-amp
 Batteries — Dual, Motorcraft® 12-volt; 1800 CCA total
 Brakes — Front/rear disc, hydraulic split system with 3-channel Anti-lock Brake System (ABS)
 Cruise control
 Emissions — 50-state-certified
 Engine — 4.5L Power Stroke® V6 Turbo Diesel
 Shock absorbers — Front
 Springs — Auxiliary rear, Aeon rubber, 1500-lb. rating
 Stabilizer bar — Front
 Steering — Power, Ross TAS37
 Transmission — TorqShift™ 5-speed automatic with Tow/Haul Mode

EXTERIOR

Bumper — Front, Argent molded-in-color
 Cab steps — Integrated into wheel lip
 Clearance lamps — 5 roof-mounted
 Doors — With drop window and black handle
 Grille — Dark Shadow Grey
 Headlamps — Jeweled-appearance
 License plate surround — Molded into front bumper fascia
 Mirrors — Dual sideview 6" x 11" rectangular, and 8" x 6" convex rectangular with breakaway-type brackets; 102"-wide spacing
 Tinted glass
 Tow hooks — 2 front
 Wipers — Fixed and interval settings with wet-arm washer fluid delivery

INTERIOR

Cupholders — 2 integrated into instrument panel
 Dome light — Door-operated or manual switch
 Door trim — With map pockets (1 per door)
 Floor covering — Vinyl
 Grab handles — 2 A-pillar-mounted
 Headliner — Color-coordinated cloth
 Heater — With defroster and 4-speed blower motor
 Horn — Electric
 Instrument panel — Color-coordinated with 3 glove compartments, 2 storage bins, air registers, left-hand and center ashtrays, and cigar lighter
 Instrumentation — Tachometer, trip odometer, fuel gauge, coolant temperature gauge and indicator lights
 Mirror — Rearview
 Overhead storage — Full-length open-bin
 Power door locks and power windows with one-touch-down driver's-side feature
 Power point — Right-side, located below instrument panel
 Safety belts — 3-point (driver and outboard-passenger) and lap belt (center)
 Scuff plates — Color-coordinated with interior trim
 Seat — Driver's tilt, high-back cloth with integral head restraint
 Seat — Center passenger high-back cloth with integral head restraint and folding seatback with notebook tray and 2 cupholders
 Seat — Outboard passenger high-back cloth with integral head restraint and folding seatback
 Steering column — Tilting and telescoping
 Steering wheel — 16"-diameter
 Sun visors — Vinyl with driver's-side strap
 Transmission shift control — Floor-mounted with button for Tow/Haul Mode

FEATURES AND OPTIONS

L45

L55

MECHANICAL

- — Axle, front — Dana Spicer® 6000-lb. I-Beam-type
- ● Axle, front — Dana Spicer 7000-lb. I-Beam-type*
- — Axle, rear — Dana Spicer 11,000-lb. single-reduction
- ● Axle, rear — Dana Spicer 13,500-lb. single-reduction**
- ○ Engine block heater
- ● Fuel tank — 40-gallon capacity steel, mounted between frame rails, aft-of-rear axle
- ○ Fuel tank — 35-gallon capacity steel, rectangular, mounted to left side of frame†
- ○ Fuel tank — Dual 35-gallon capacity steel (70-gallon total capacity), rectangular, mounted to left and right sides of frame†
- — GVWR — 16,000-lb.
- — GVWR — 15,000-lb.
- ● GVWR — 19,500-lb.
- ○ GVWR — 17,999-lb.
- ○ PTO (Power TakeOff) provision — Opening on left side of transmission
- ○ Shock absorbers — Rear
- ○ Spare — Matching wheel and tire‡
- — Springs, front — 6000-lb. tapered leaf
- ● Springs, front — 7000-lb. tapered leaf‡
- — Springs, rear — 11,000-lb. single variable-rate
- ● Springs, rear — 13,500-lb. single variable-rate‡
- ● Tires — 225/70R19.5 Goodyear G647RSS‡ load-range F (6)
- ○ Tires — 225/70R19.5 Michelin XZE, load-range F (6)
- ○ Tires — 225/70R19.5F XDE M/S, rear traction tires (4)
- ● Wheels — 19.5" x 6" hub-piloted, 10-lug, painted-white steel (6)
- ○ Wheels — 19.5" x 6" hub-piloted, 10-lug, polished-aluminum (6)

L45

L55

EXTERIOR

- ○ Backup alarm
- ○ Daytime running lamps
- ○ Grille — Chromed
- ○ Tailamps delete

INTERIOR

- ○ Air conditioning
- ● AM/FM stereo with clock
- ○ AM/FM stereo with single-CD player and clock
- ○ Power windows and door locks delete
- ○ Remote keyless-entry system with panic alarm and audible lock confirmation
- ○ Radio Prep Package — Includes wiring and antenna with multiple dual-cone speakers; radio not included
- ○ Vinyl-covered seating

● Standard ○ Optional — Not Available

*Requires 7000-lb. front springs.
 **Requires 13,500-lb. rear springs.
 †Not available with 113" wheelbase.
 ‡Late availability.
 †Requires 7000-lb. front axle.
 †Requires 13,500-lb. rear axle.

Comparisons based on 2006 competitive models, publicly available information and Ford certification data at time of printing. Some features discussed may be optional. Vehicles shown may contain optional and aftermarket uplift equipment. Features shown may be offered only in combination with other options or subject to additional ordering requirements or limitations. Dimensions and capability ratings shown may vary due to optional features and/or production variability. Following publication of the catalog, certain changes in standard equipment, options and the like, or product delays may have occurred which would not be included in these pages. Your Ford Dealer is the best source for up-to-date information. Ford Division reserves the right to change product specifications at any time without incurring obligations. Body Manufacturers are responsible for compliance certification of the completed vehicle. The Ford LCF Limited Warranty and any government certification made by Ford shall cover only the vehicle as manufactured by Ford and shall not extend to any addition, modification, or change of or to the vehicle by the Ford Authorized Pool Account.



EXTERIORS

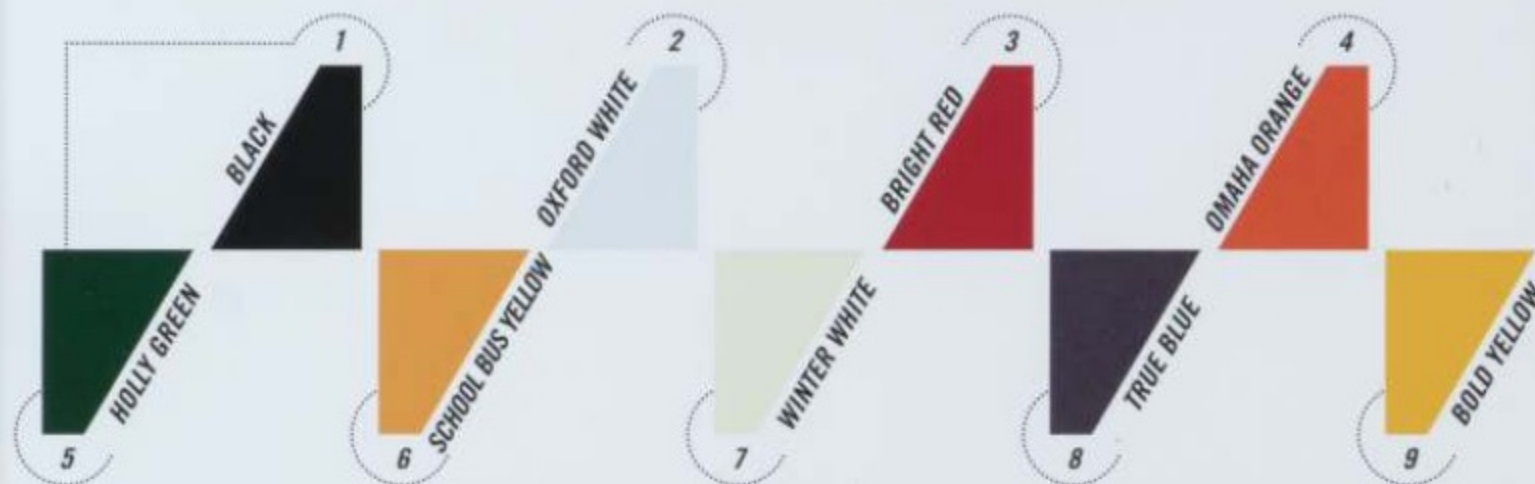

INTERIORS



For 2007, **FLINT GREY CLOTH [A]** is the standard seating surface on both LCF models. **FLINT GREY VINYL [B]** is available on both models as a Cloth Delete Option. Standard **POWER DOOR LOCKS** and **POWER WINDOWS** with driver's-side one-touch-down feature complete this year's interior upgrades. For added comfort and security, choose air conditioning with integral heater/defroster, and/or remote keyless-entry system with panic alarm and audible lock confirmation.

19.5" WHEELS



19.5" x 6" hub-piloted, 10-lug **PAINTED-WHITE STEEL WHEELS [A]** and 225/70R19.5 Goodyear G647 tires (load range F) are standard on both LCF models. 19.5" x 6" hub-piloted, 10-lug **POLISHED-ALUMINUM WHEELS [B]** and 225/70R19.5 Michelin XZE tires are also available on both LCF models or 225/70R19.5 Michelin XDE M/S rear traction tires.

2007 FORD LCF

BUILT FORD TOUGH
DESIGNED AND BUILT TO MEET THE DEMANDS
OF NORTH AMERICAN BUSINESSES

BEST-IN-CLASS TURNING RADIUS

- 16'5" CURB-TO-CURB
- 18'4" WALL-TO-WALL
- 53° WHEEL CUTS

BEST-IN-CLASS POWER AND TORQUE

- 4.5L POWER STROKE™ V6 TURBO DIESEL
 - 200 HORSEPOWER
 - 440 LB.-FT. OF TORQUE
- 2 MILLION MILES OF TESTING

CAPABLE WORK TRUCKS

- 4 GVWR OFFERINGS: 15,000 AND 16,000 LBS. (L45);
17,999 AND 19,500 LBS. (L55)
 - STRONGEST STANDARD FRAME (RBM)
 - 4-WHEEL DISC BRAKES WITH ABS
- EXCLUSIVE HUCK BOLT™ FRAME CONSTRUCTION
 - 19.5" WHEELS AND TIRES

NO-CHARGE EXTRAS

- 9 EXTERIOR COLOR CHOICES
- STANDARD POWER WINDOWS AND DOOR LOCKS
- STANDARD CLOTH INTERIOR TRIM

For more information on Ford Commercial Vehicles,
go to www.comtruck.ford.com



© 2006 Ford Motor Company. 07LCFAT
Litho in USA on recycled paper (20% post consumer)