

1981 DODGE
PICKUPS
ARE BUILT TOUGH!

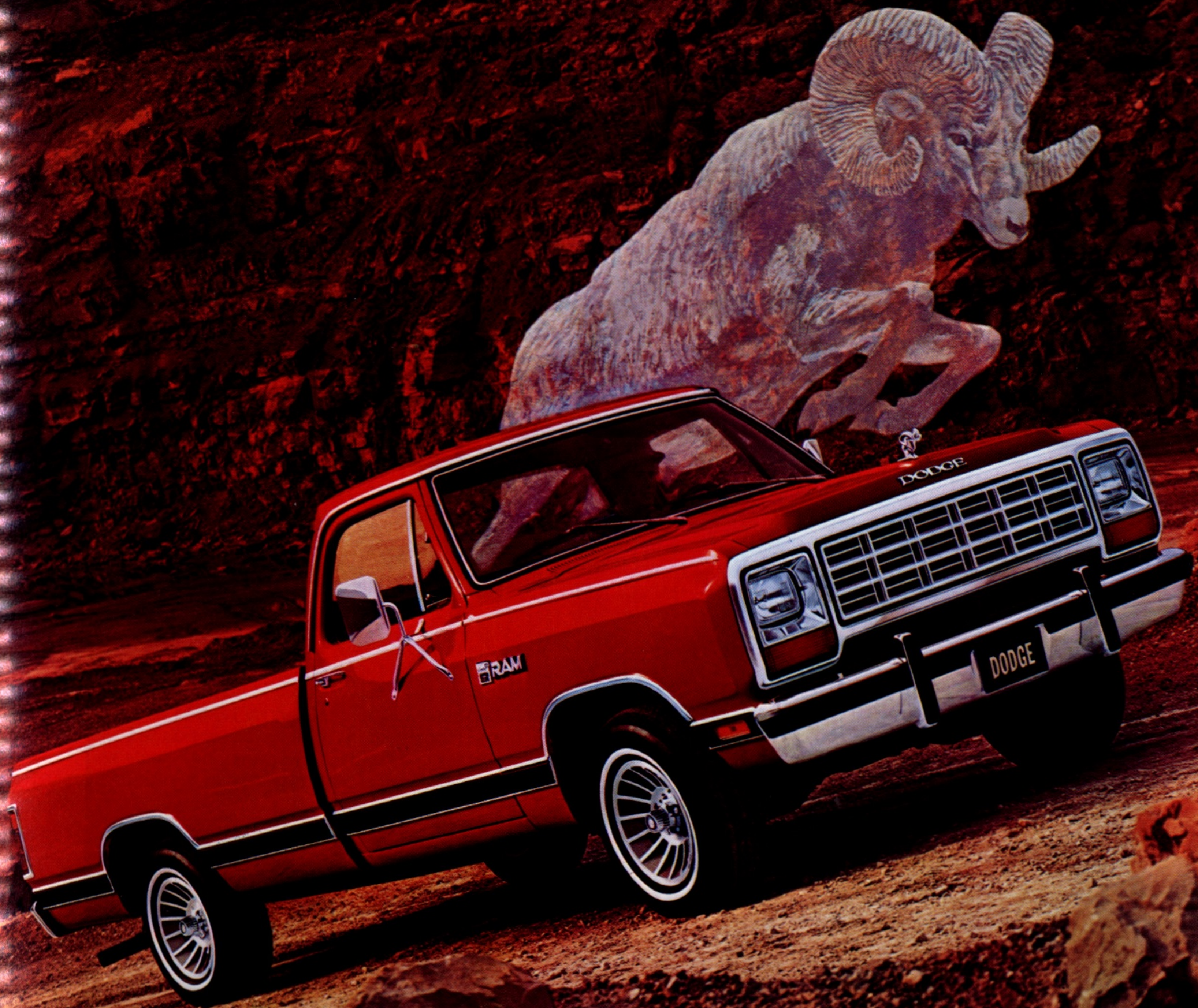



DODGE TOUGH PICKUPS

The Dodge Pickup line for '81 boasts an exciting new look with a bold new grille and sculptured sheet metal, and the same good reputation for dependability it has enjoyed for years. Whether your needs call for the conventional pickup, club or crew cab, or sport utility, Dodge has it. It doesn't matter whether you intend to work or play with it, Dodge has it. If the payoff is payload, Dodge has that, too . . . as much as 5,690 pounds of it in the D350. "Tough" really describes Dodge trucks.



INTERIOR & CARGO

Truck design is concerned with two things—the job that has to be done and the people who have to do it. Your Dodge Pickup satisfies both concerns, from its reinforced cross-member frame construction to its well appointed cab interior with re-designed instrument panel, new seats and fabrics. Cargo and comfort ride together in a pickup by Dodge!



Standard "Big Horn" Interior

DODGE TOUGH CREW CAB

When seating requirements go beyond the conventional 3-passenger cab, Dodge has a roomy Crew Cab capable of seating six adults—comfortably. It could be a work crew, or it could be a family on the go, you can still carry people and cargo because Crew Cab is available with either 6½ or 8-foot box. It's also available in four-wheel drive.

That's not all . . . interior trims and seating are available in two stylish levels. And exteriors are available in fifteen colours and several smart two-tone combinations. Great choice . . . choice truck!



DODGE TOUGH CLUB CAB

Another way to beat the passenger pinch is with the Club Cab. It gives you an extra 34 cubic feet of space behind the front seat . . . just enough room to carry two passengers in optional swing-down seats.

Or, if, passengers aren't a concern, maybe security is. That extra inside space is the perfect spot to store tools or carry cargo you don't want exposed. It's an alternative worth considering.

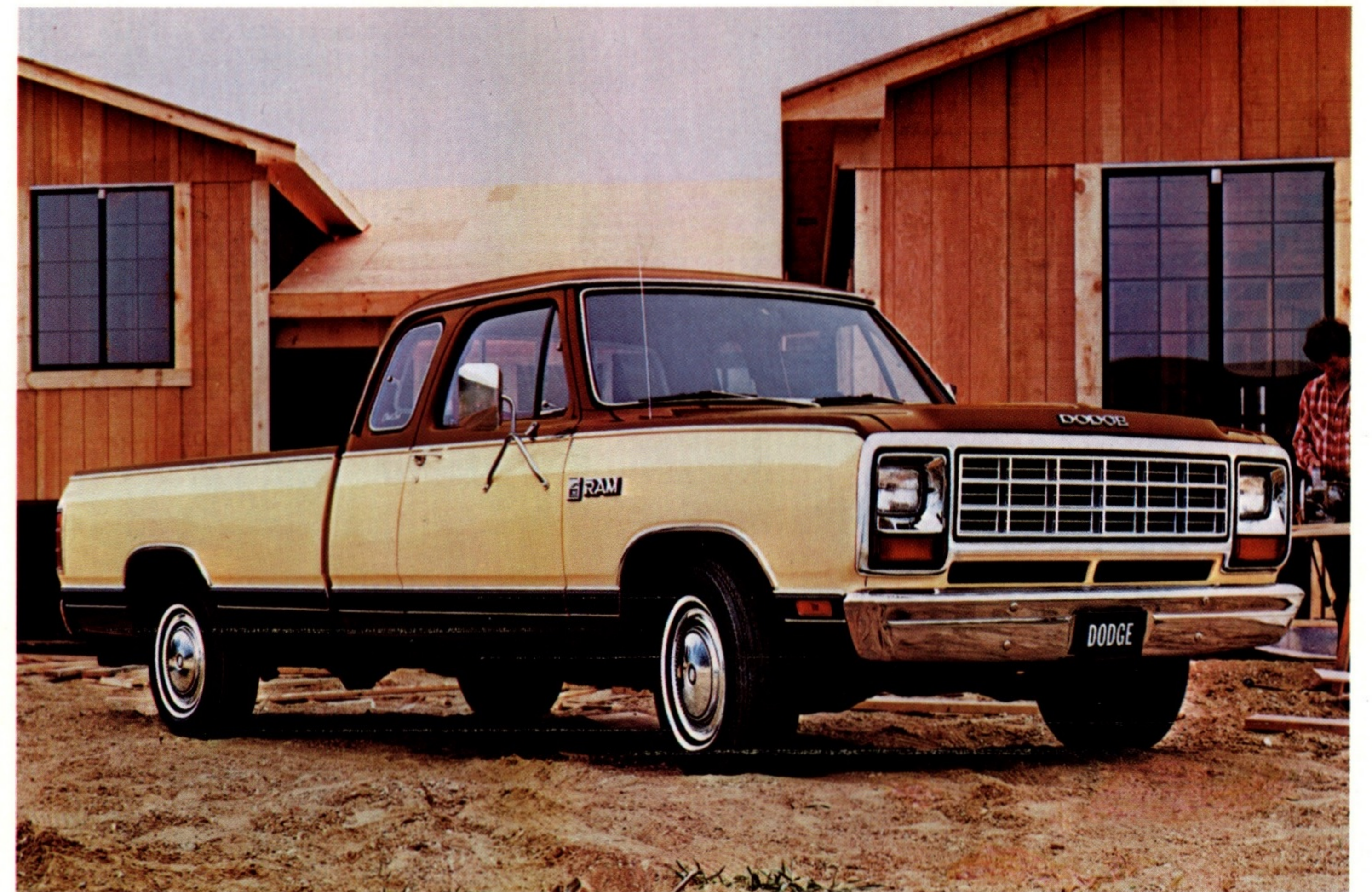



DODGE TOUGH FOUR-WHEEL-DRIVE PICKUPS

The pickup that doesn't need a road to travel on. It's available in all cab styles and incorporates a "part-time" four-wheel-drive transfer case and front-wheel locking hubs. Economical to drive and capable of off-road operation. This vehicle really does the job.

For 1981, A Macho Package is available with 5-spoke painted road wheels and tires outlined in white letters, decorative tailgate decals and a special blackout paint set off with distinctive tape stripes. It makes a very attractive vehicle even more attractive . . . downright Macho!

FOUR-WHEEL-DRIVE PICKUPS

Four-wheel-drives are most effective in irregular terrain, sand, snow and anywhere that traction is uncertain. Power delivered to the front as well as the rear wheels is a distinct advantage. But when that's not necessary . . . when the roadbed is good . . . why deliver all that power? That's where Dodge's "part-time" application comes in. Shift into rear-wheel-drive range, unlock the front wheel hubs, and you're back in conventional two-wheel operation. Simple, and it saves fuel, too.



PICKUP BOXES

Utiline, as shown top right, with side steps, and Sweptline, just below, takes advantage of aerodynamic styling for larger cargo capacity. Either box is available in 6½ and 8-foot lengths, and capable of delivering a maximum payload of 5,600 pounds.

Regardless of payload, you can enjoy the luxury of Royal driver-passenger options.

- (1) 6½ Foot Box
- (2) 8 Foot Box

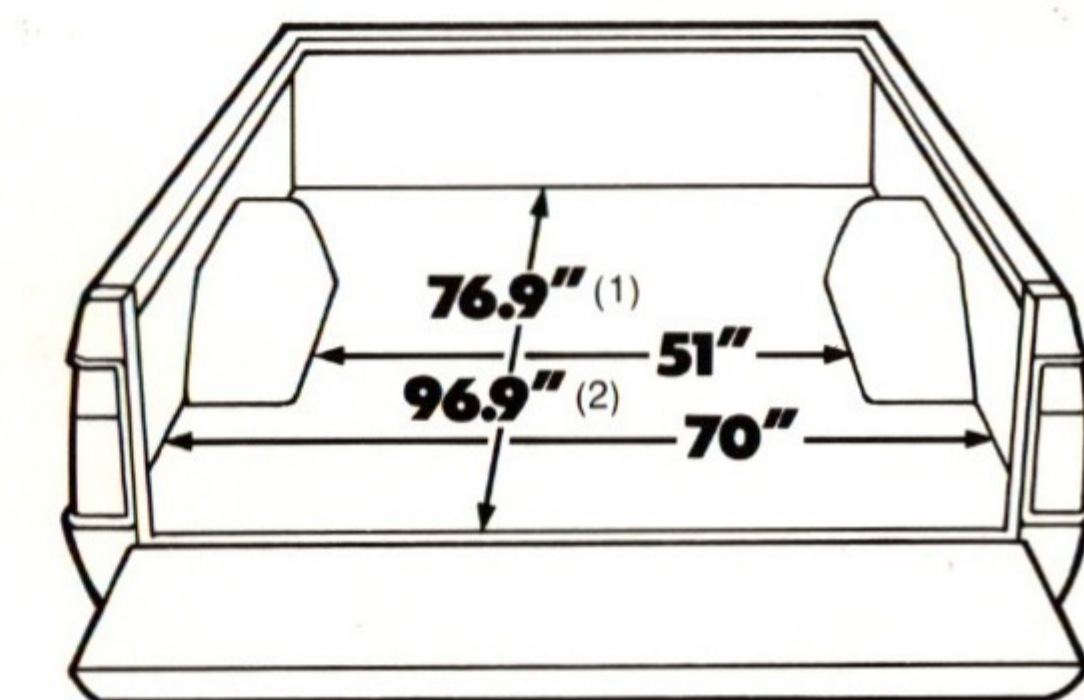
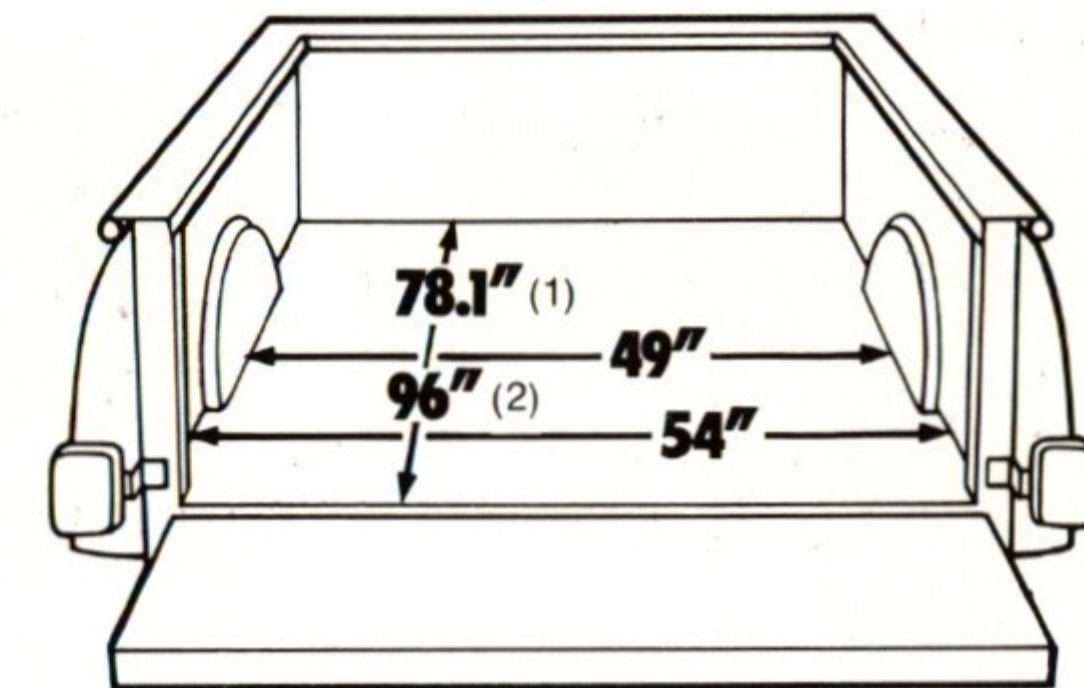

CARGO CAPACITY

If "loadability" is what you look for in a pickup; don't be afraid to pile on that cargo . . . Dodge pickups can take it!, and come back for more. 36,000 psi carbon steel frames, double-walled pickup boxes and rear axles with capacities up to 7500 pounds (on D 300 models) all mean Dodge pickups will perform when put to the test. Furthermore, the availability of two pickup box lengths and the wide selection of powerplants allows you to 'tailor' your pickup to suit individual needs.



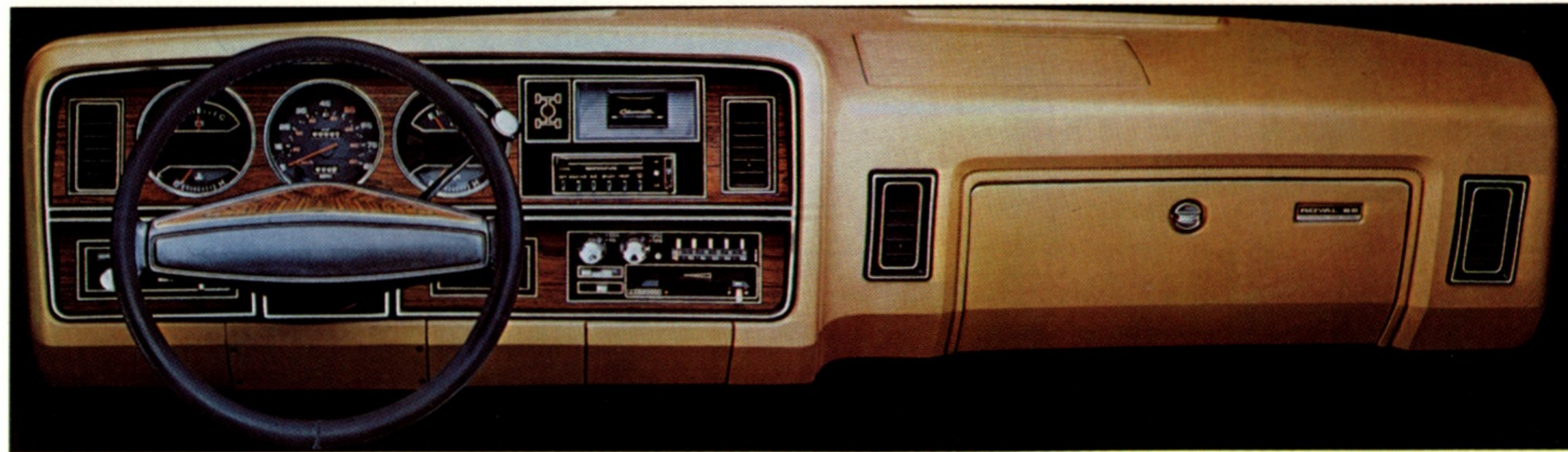

INSTRUMENT PANEL

The design of the all-new, handsome one-piece instrument panel for '81 shows proper concern for operator convenience and quiet, solid construction. Information clusters are neatly arranged for quick driver check, and details are

boldly displayed. Controls for radio, heater, and air conditioning are at arm level and within fingertip reach. A tilt steering wheel is optional . . . a further move toward driver comfort and convenience.

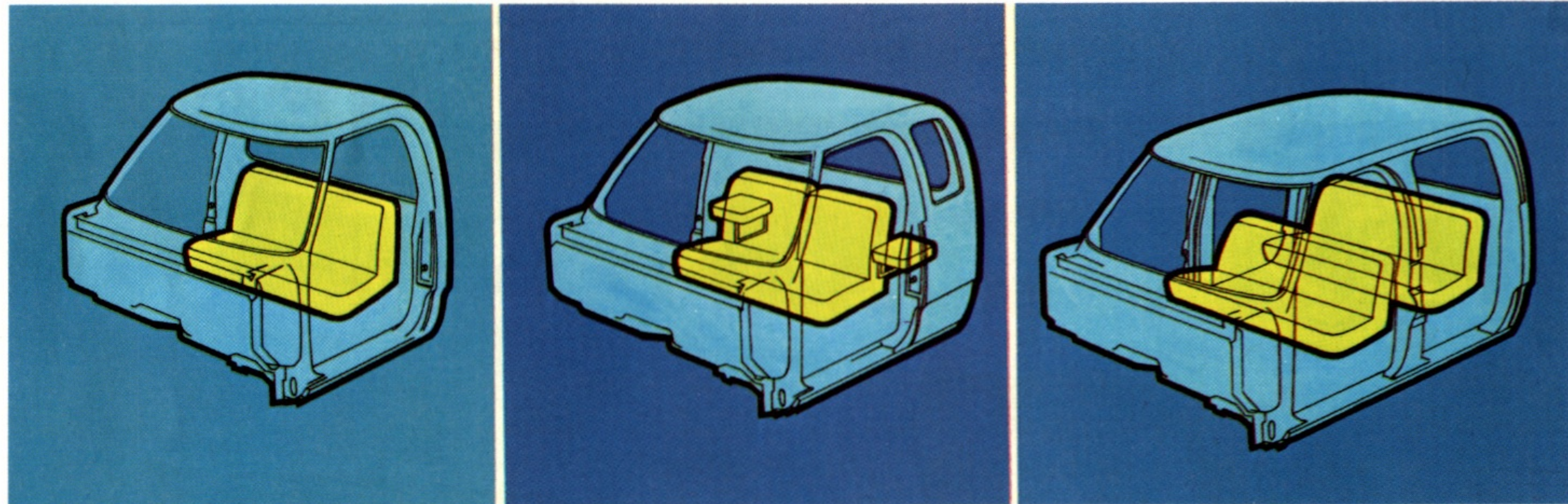

SEATING OPTIONS

Your choice of seating begins with the comfortable, all-vinyl, 3-passenger bench seat, standard in the conventional cab. But it doesn't stop there. You can specify several options which provide for hinged back and bucket seats, whatever your need may be.

In the Club Cab, with its 34 cubic feet of extra storage or optional seating, you'll need a hinged back front seat. Dodge offers that as standard in a deluxe vinyl trim.

The Crew Cab is standard equipped with bench seats, front and rear, but the hinged back rear seat is available in an attractive cloth-and-vinyl option.

Pick a seat, pick a trim level. Your Dodge Truck dealer can show you a wide variety of ways to get the comfort you want in your '81 pickup!



Optional Club Cab Jump Seats



Optional Royal Cloth & Vinyl Bucket Seats



Optional Royal SE Leather & Vinyl Bench Seat

INTERIOR TRIM AND SEATS

Dodge offers you four trim levels that are as good looking as they are functional. There's the standard Custom with its colourful, serviceable, all-vinyl trim. Custom SE in cloth and vinyl or optional vinyl, Royal and Royal SE—both with vinyl and cloth or vinyl only choices.

If you'd like, you can step up to the attractive Big Horn package with its look of simulated rawhide and white fleece accents.

Dodge Pickup interiors are available in black, blue, cashmere and red; seats and door panels and floor coverings are all colour-keyed to present the most attractive environment possible.

High style and real function go together in your Dodge Pickup for 1981!



Optional Custom SE Cloth & Vinyl Bench Seat



Optional All-Vinyl Bucket Seats



Ramcharger "Big Horn"

DODGE TOUGH RAMCHARGER

Ramcharger with its bold new front grille treatment is a work-play vehicle that says sometimes a truck isn't a truck at all. It's a 106-inch wheel-base Sport Utility vehicle with a 5.2-litre (318 cu. in.) 8-cylinder engine that carries people over any kind of terrain, and for any kind of purpose. The roof is an integral design, has bonded rear quarter glass that curves up into the roof panel, and has a rear roof ventilator, standard. The liftgate is one piece fibreglass for solidity and corrosion resistance. And you take your choice of carrying passengers or cargo.



All-Vinyl Low-Back Bucket Seats

Ramcharger can accommodate up to six passengers with optional seating.

With Dodge's optional "part-time" four-wheel-drive . . . front wheel locking hubs . . . power steering . . . front disc brakes, and a whole string of options, Ramcharger leads the way in versatility and value!



INTERIOR

Ramchargers' interiors are just what you'd expect them to be—tough and terrific, smart and versatile. Improved rear passenger comfort is provided with a dropped floor surface forward of the rear bench seat. Bench seats, buckets . . . even a lockable console with removable beverage chest is offered as an option.

New for 1981 is the Big Horn Package—highback Command bucket seats in vinyl that looks like real rawhide with simulated white lamb's wool trim. Fantastic!

The Big Horn Package extends to the exterior treatment, too . . . lots of dress-up features, in and out, that you'll be proud of.

Then there's the Macho Package with special blackout paint treatment outside set off by special bright tape stripes and special road wheels, outlined white-lettered tires and other striking features. Macho is a good word for this optional treatment!



CARGO LOADING

Loading your Ramcharger is simple with its one-piece fibreglass liftgate—new for '81. Light and sturdy, it lifts out of the way to provide the widest possible cargo opening.

The optional fold-up rear bench seat can be moved out of the way to accommodate larger loads, and tire storage is neatly behind the wheel well. Ramcharger is what you want it to be!



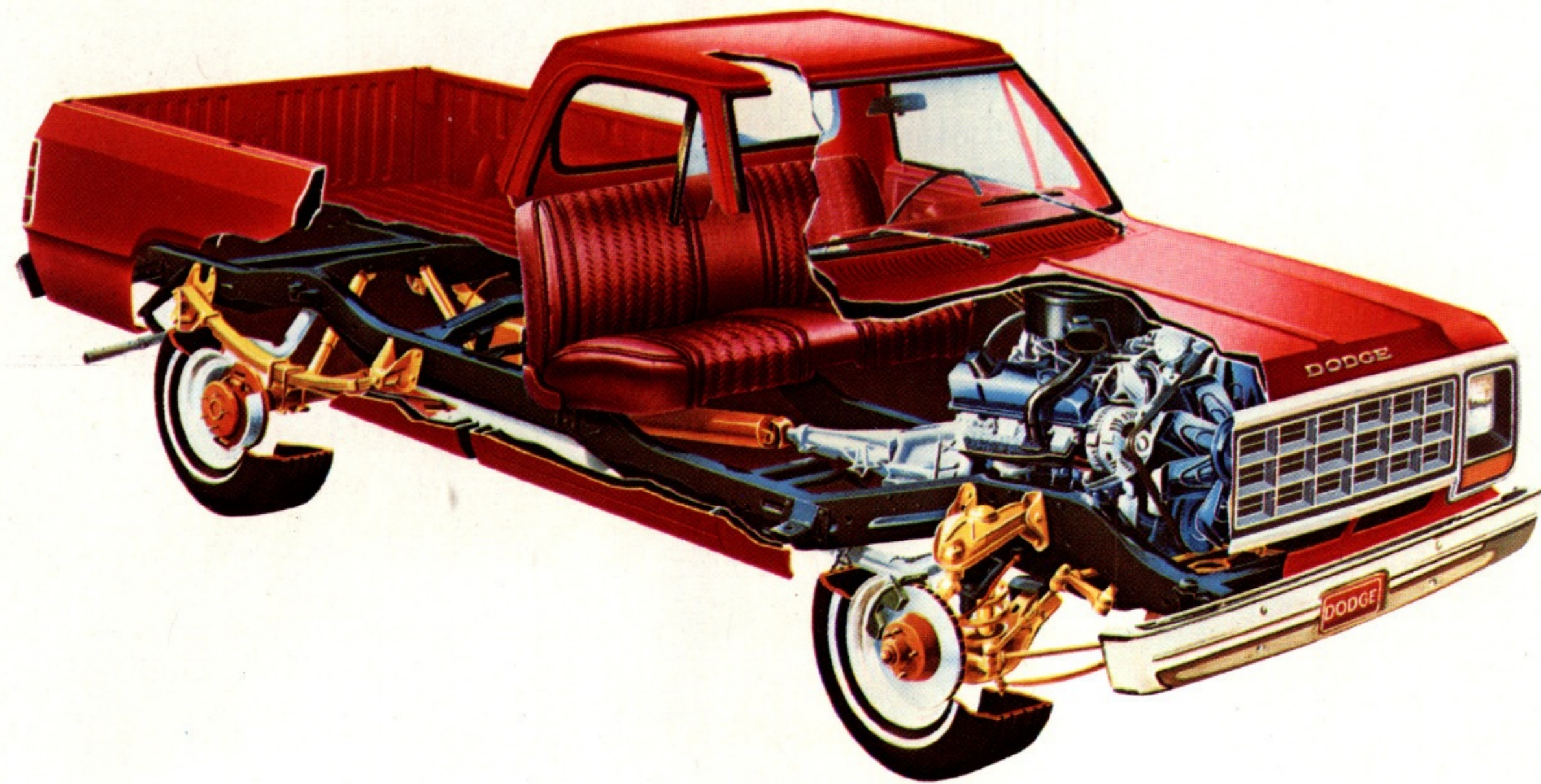

QUALITY CONSTRUCTION

Dodge trucks are the product of exceptional engineering and quality manufacturing. The objective: to provide you with a truck capable of doing the job you want done, and to do it with your comfort, economy, safety and assurance in mind. Here are some of the benefits you'll enjoy:

A better view of the road with a large windshield. A quieter ride with extensive soundproofing. Easier handling with recirculating ball steering, independent front suspension and coil front springs matched to on-the-job performance. Safer, surer stops with front disc brakes and rear drum brakes. Improved fuel economy as a result of overall weight reduction and engine-transmission-driveline ratios. Optimum load-carrying capabilities assured by a 7 cross-

membered carbon steel frame and rear axles designed for your payload requirements. Ease of upkeep and continued good appearance due to the use of galvanized steel in exposed body parts, double-wall cargo box construction, integral rear fender caps that eliminate possible moisture entrapment and eventual corrosion, and a 5-step dip and spray treatment prior to final finishing. Ease of loading and unloading and cargo-in-transit security with the newest in tailgate engineering. Improved reliability and operation as a result of electronic technology.

Comfort, appearance, utility, safety, economy and dependability—all yours with Dodge Trucks for 1981.

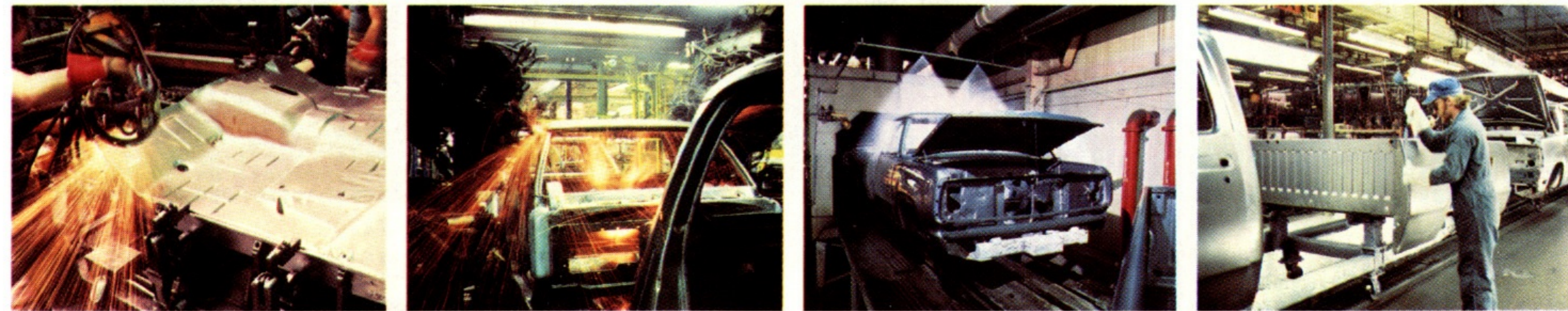

RUSTPROOFING

Trucks are exposed to all kinds of weather, roads and environments. Little wonder that trucks often show the effects of corrosion.

Dodge has an answer—an exceptional anti-corrosion process that begins with the use of galvanized steel in exposed areas. Add to that a dip-and-spray process that gets protective coatings into every nook and cranny in the underbody. Top that with zinc-rich primers over the entire body and pickup box and vinyl seam sealers in seams and corners. Finally, high-bake, high-gloss acrylic enamel that is particularly resistant to scratches and chipping.

Little wonder that Dodge trucks have a reputation for looking good, longer than the competition!

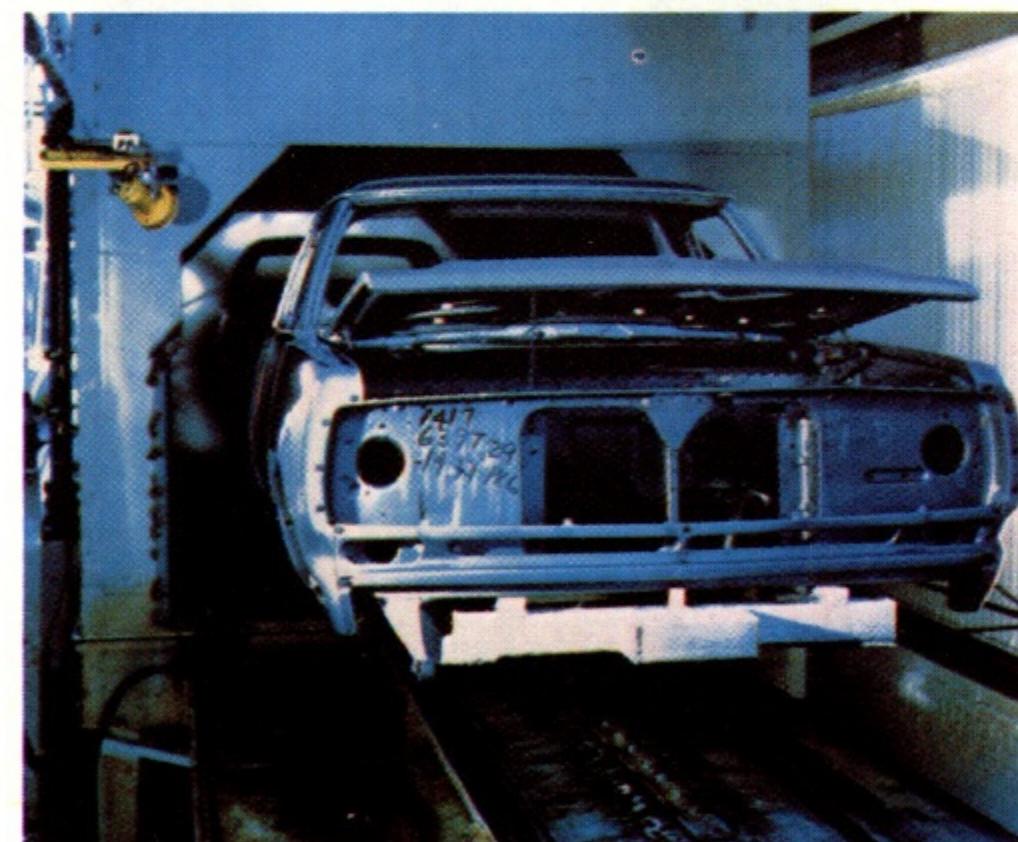

RECREATIONAL VEHICLES

Pull it, stack it on top, or build it on, your Dodge Truck can accommodate your RV needs. That's why the Dodge nameplate is so familiar in campgrounds and on the road.

Carefully engineered trailer towing and camper carrying packages are available to the RV minded buyer. These packages properly combine engines, drivelines and suspension systems to meet your particular requirements. Also, a heavy-duty electrical system is there to handle the added RV load. Trailer harness and hook-up, too.



Hitch it up, or slide it onto your Dodge Pickup, and your home-away-from-

home will provide you a carefree holiday!

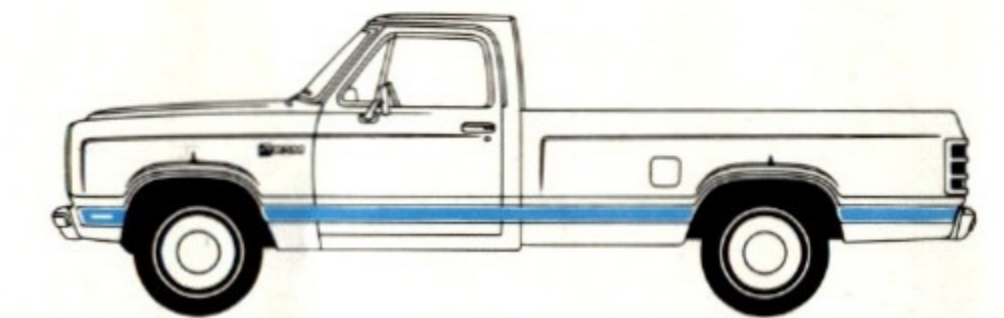
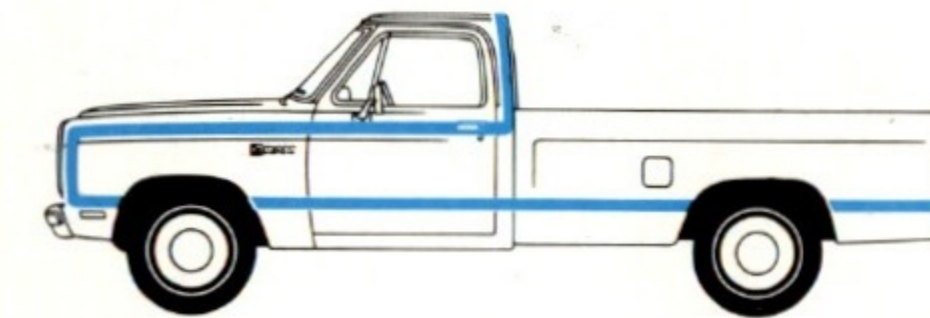
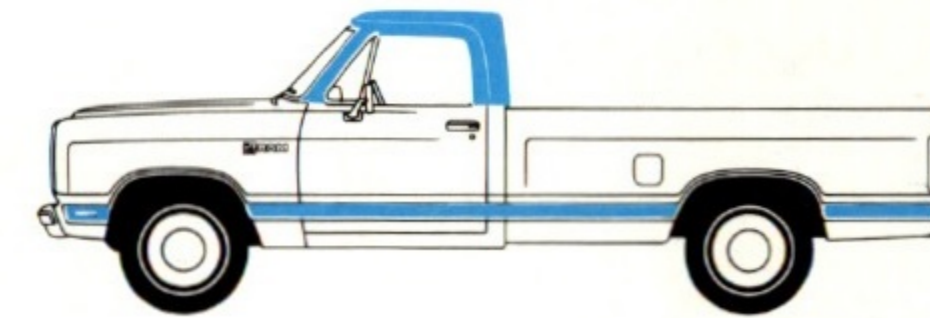

SPECIAL PAINT OPTIONS

For the truck owner who likes it simple and solid, Dodge gives you fifteen attractive exterior colours to choose from. But, if you go for two-tones and stripes, Dodge makes that easy, too. One attractive option is to have the body and box one colour and the cab

roof a second colour. That option is available on both the Utiline and Sweptline models.

In the Sweptline series a main colour is applied to the extreme lower body and to the hood and cab roof. A second colour runs the full length of

the truck, along the beltline . . . set off from the lower body with a distinctively wide decorative moulding.

Macho and Bighorn treatments are also available and are described in this catalogue. Consult with your Dodge dealer on these special paint options.

DODGE PICKUP BASIC SPECIFICATIONS

| Model | Body Style | | Cab Style | | | | GVWR* (Pounds) | | Payload Allowance** (Pounds) | |
|-------|------------|---------|------------------|----------|----------|---------------|----------------|--------|------------------------------|-------|
| | Sweptline | Utiline | Conventional Cab | Club Cab | Crew Cab | Sport Utility | Min. | Max. | Min. | Max. |
| D150 | X | X | X | X | | | 4,800 | 6,010 | 1,330 | 2,470 |
| D250 | X | X | X | X | X | | 6,500 | 8,550 | 2,640 | 4,875 |
| D350 | X | | X | X | X | | 9,000* | 10,000 | 4,545 | 5,690 |
| W150 | X | X | X | X | | | 6,050 | 6,050 | 1,700 | 2,075 |
| W250 | X | X | X | X | X | | 6,900 | 8,550 | 2,575 | 4,170 |
| AD150 | | | | | | X | 5,300 | 5,300 | 1,450 | 1,450 |
| AW150 | | | | | | X | 6,010 | 6,010 | 1,645 | 1,645 |

* Gross Vehicle Weight Rating.

** Payload allowance indicated must be reduced by weight of optional and added equipment and weight of Driver/Passenger(s).

Min.—Minimum.

Max.—Maximum.

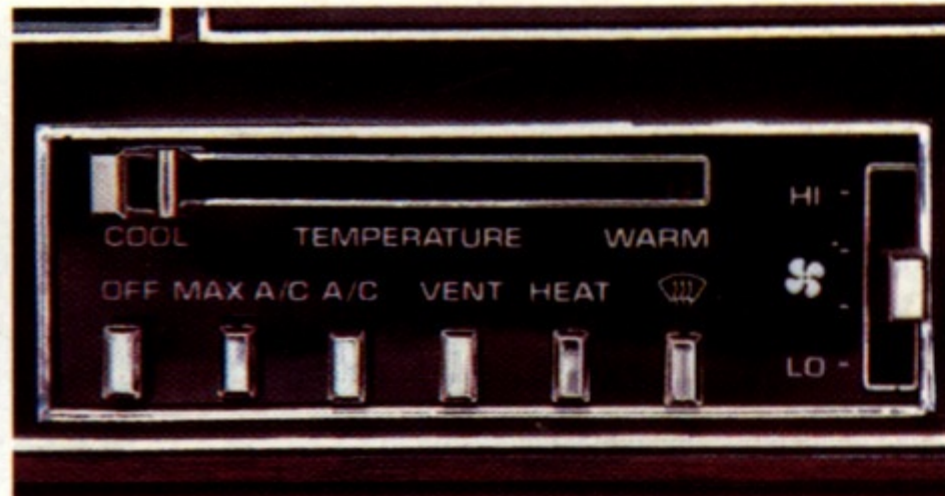

B

C

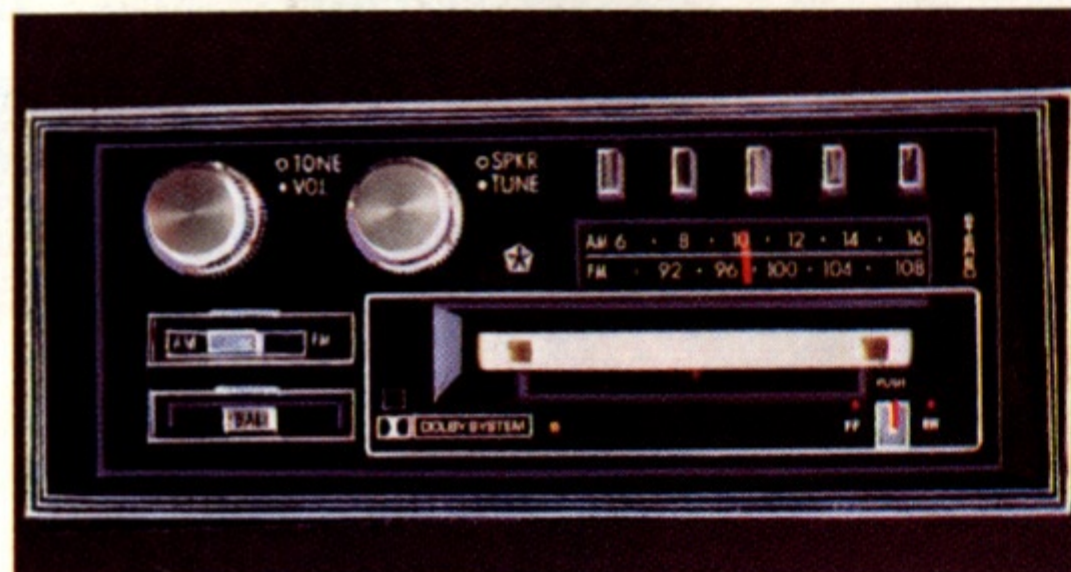

E

F



D

G

H

I

Dodge Pickup Options pay off in convenience, good looks!

- A. **Sun Roof.** A car-like feature that is good-looking and useful. Can be opened slightly or removed completely to let the outdoors in.
- B. **Air Conditioning** keeps you cool on hottest days. An efficient, powerful system that features rapid cool-down, quick temperature modification, easy-to-reach controls.
- C. **Digital Clock** keeps excellent time, is quiet in operation, easily visible night or day. Features separate hour and minute reset controls.
- D. **Sliding Rear Window** provides additional interior ventilation on hot days and makes it easy to communicate when you're carrying a camper unit.
- E. **AM/FM/MX Stereo Cassette Player** has Dolby* noise reduction system. Lets you put more pleasure into your workaday world.
*Trademark, Dolby Laboratories
- F. **Aluminum Ribbed Wheels and Wheel Covers** enhance the sporty good looks of your Dodge Pickup.
- G. **Speed Control** conserves fuel and eases the strain of long-distance highway driving. You set your cruising speed, the control maintains it for you. Instantly disengages when you brake.
- H. **Power Windows.** One more way Dodge looks to your comfort and convenience. Fingertip controls let you open and close both front windows.
- I. **Step-Type Bumper with Skid Plate** makes climbing into and out of your Dodge pickup safe and easy.

Buy, Rent or Lease from your Dodge Truck Dealer

See your dealer for more complete specifications

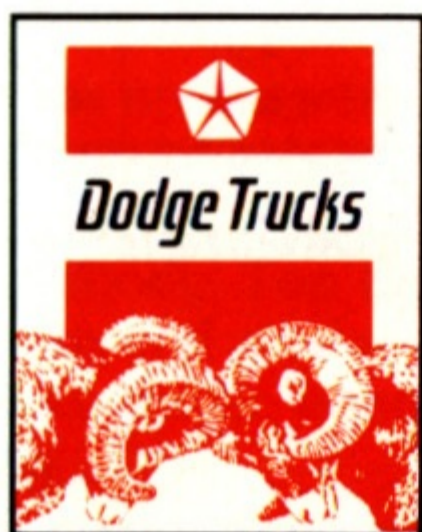

DODGETOUGH

All product illustrations and specifications are based on authorized information. Although descriptions are believed correct at publication approval, accuracy cannot be guaranteed. Some of the equipment shown on product illustrations is optional, at extra cost. Chrysler Canada Ltd. reserves the right to make changes from time to time, without notice or obligation, in prices, specifications, standard and optional equipment listed, colours and materials, and to change or discontinue models.

