

THE NEW
2008 E-SERIES



2008 E-SERIES

YOU CAN'T KEEP A GOOD VAN DOWN

ACROSS CANADA, MORE PEOPLE TRUST E-Series Cargo Vans, Cutaways and Wagons to haul products, deliver emergency medical services, get them where they need to go, and more. They know it takes more than a Yukon winter, Rocky Mountain pass, or Toronto grid-lock to stop these Built Ford Tough® trucks. Plus, the widest range of configurations means they can always choose the vehicle that's just right for the job. Capability, durability and flexibility make E-Series the trucks that keep coming back for more, and the best-selling vehicles in their class¹ for 15 years in a row.²

¹Class is Full-Size Vans. ²Based on Canadian Vehicle Manufacturers' Association statistical sales report, December 2006.

Vehicles throughout this catalogue are shown with optional and aftermarket upfit equipment.



CAPABILITY

THE ONLY STANDARD CARGO VAN V8 IN THE CLASS!¹
UP TO 4536 KG (10,000 LBS.) CUTAWAY TOWING.²

THE ONLY V10 GAS OPTION IN THE CLASS also delivers best-in-class gas horsepower and torque.

HIGHER GVWRS AND SEGMENT-LEADING GCWRS — E-Series starts strong and gets stronger. From E-150 with best head-to-head base payload of 1515 kg (3340 lbs.)⁴ to the upgraded capabilities of E-350 and E-450, you have even more choices than before.

7- TO 15-PASSENGER SEATING lets you order Wagons that suit your individual needs.

¹Properly equipped. ²Comparison of properly equipped E-150 to 1500 Series Full-Size Vans.

CONFIDENCE

ALL-NEW BRAKE SYSTEMS deliver enhanced capability and durability.

AVAILABLE E-GUARD CARGO PROTECTION SYSTEM™ reinforces rear- and side-door locks.³

5-YEAR/100,000-KM POWERTRAIN LIMITED WARRANTY + ROADSIDE ASSISTANCE

³Available on Commercial Van with 60/40 split side cargo doors.

CONTROL

ADVANCETRAC® WITH RSC® (ROLL STABILITY CONTROL™) is groundbreaking technology you can't get on any other full-size van. It's standard on any E-350 Wagon equipped with the 5.4L Triton® V8.

SUSPENSION AND STEERING have been improved to deliver enhanced performance. You will experience a more responsive "E."

TRACTION CONTROL is now available on gas engine applications.

2008 E-SERIES

GETTING **TOUGHER** ALL THE TIME

AN IMPROVED CHASSIS AND NEW SYSTEMS deliver enhanced capability and security. Here are just some of the features that help make E-Series a stronger, more useful vehicle for you.

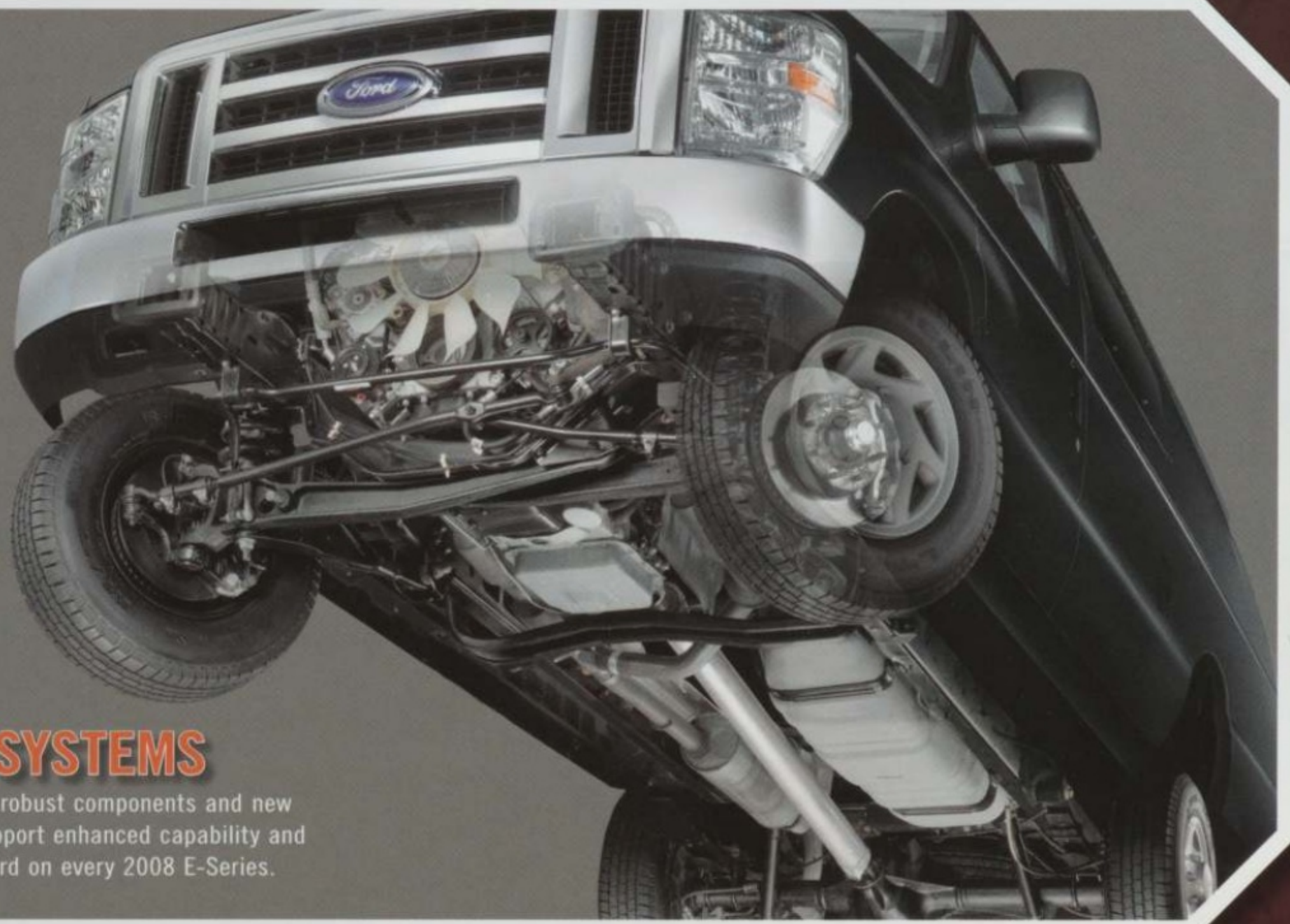

ALL-NEW **BRAKE SYSTEMS**

with larger, more robust components and new pad materials support enhanced capability and durability. Standard on every 2008 E-Series.

RE-ENGINEERED **SUSPENSION & STEERING**

feature a revised front suspension system that includes redesigned front sway bars to help deliver solid handling. Front and rear shocks are rated to the load range of each model and tuned to deliver a smooth ride. A new steering gear boost-curve enhances road feel and provides excellent steering feedback to the driver.

NEW **TRACTION CONTROL**

is now optional on gas engine applications without Roll Stability Control. The system reduces engine power whenever it detects wheel spin.

NEW **SECURILOCK®** PASSIVE ANTI-THEFT ENGINE IMMOBILIZER SYSTEM

is available on single-rear-wheel models and designed to help prevent the engine from being started unless a coded key programmed to your vehicle is used.

NEW **TIRE PRESSURE MONITORING SYSTEM (TPMS)**

is now standard on all single-rear-wheel models. It alerts the driver whenever any mounted road tire drops below a certain pressure. (Excludes spare tire.)

2008 E-SERIES WAGONS

FLEXIBLE FLYERS



WHEN MOVING PEOPLE IS THE TASK, E-Series Wagons fill the bill. Seating configurations include 7-, 8-, 11-, 12-, or 15-passenger.¹ Standard air conditioning helps keep everyone comfortable, and there's room for your crew and all their gear. Rear bench seats now have centre-position 3-point seat-integrated safety belts. And a new self-latching system for rear seats makes removal and installation a snap. Lots of comfort and lots of choices are the keys to this very flexible "E."

ADVANCETRAC RSC

AdvanceTrac® with RSC® (Roll Stability Control™) can help in many real-world situations, such as when you're driving on slippery surfaces like snowy, muddy, wet or gravel roads, making an emergency manoeuvre to avoid something in the road, or even just travelling on uneven surfaces such as in construction zones. Standard on E-350 Wagons with 5.4L Triton® V8².

¹Passenger and cargo capacity limited by weight and weight distribution.

²Remember that even advanced technology cannot overcome the laws of physics. It's always possible to lose control of a vehicle due to inappropriate driver input for the conditions. AdvanceTrac with RSC is only available on E-350 Wagons with 5.4L Triton V8.



2008 E-SERIES VANS

THE ULTIMATE TOOL BOX



TO CARRY THE THINGS YOU NEED MOST ON THE JOB, count on E-Series Cargo Vans. Available cargo space swallows up to 7683 litres (271 cu. ft.). Choose the right configuration to haul and tow the heaviest loads. Double-wall construction helps protect outer body work from shifting cargo. E-Series Vans also offer 4 engine/transmission combinations, the TorqShift® 5-speed automatic with Tow/Haul Mode¹, gasoline or diesel power, sliding or swing-out doors, windows all around or panel sides. No other full-size van (or even your trusty tool box) offers so much potential.

Time to load it up and get it done.

¹Gas engine applications only.

GVWRS AND PAYLOADS

MAXIMUM CAPABILITIES (KG/LBS.)	GVWR	PAYLOAD ²
E-150 VAN	3865/8520 – 3901/8600	1515/3340
E-250 VAN	4037/8900 – 4082/9000	1665/3670
E-250 EXTENDED VAN	4037/8900 – 4082/9000	1608/3545
E-350 VAN	4309/9500	1864/4110
E-350 EXTENDED VAN	4309/9500	1798/3965

²Properly equipped.

Having too much capacity can be as costly as having too little, and that can mean the difference between profit and loss. So zero in on the capability that fits your business best. Ford offers you a wide range of GVWRs and payloads to help you get exactly what you need.



NEW E-GUARD

CARGO PROTECTION SYSTEM™

provides significant reinforcement to rear- and side-door locks on Commercial Vans with 60/40 split side cargo doors. This segment-exclusive system is designed to be unlocked only with the vehicle key, even on models with remote keyless entry.

NEW STEEL-REINFORCED

REAR LICENCE PLATE HOUSING

Also equipped with a steel lock cylinder flange, it boosts the tamper resistance of the rear door lock cylinder and locking mechanism. Standard on Vans and Wagons.

NEW DOME LIGHT KIT

The Cargo Van Dome Light Kit has 3 bright lamps to fill the cargo area with light. It's now available on most Commercial Vans.



REVERSE SENSING SYSTEM

When activated, this optional feature works automatically when slowly backing up or parallel parking. It senses certain objects up to 1829 mm (6 ft.) behind your vehicle, beeping more rapidly as you get closer. It's especially helpful when rear visibility is limited. Available on Vans and Wagons with rear step or contour bumpers.

2008 E-SERIES CUTAWAYS

THE POSSIBILITIES ARE ENDLESS

MAXIMUM CAPABILITIES (KG/LBS.)	GVWR	PAYLOAD ¹
E-250 CUTAWAY SRW	3901/8600	1966/4335
E-350 CUTAWAY SRW	4354/9600	2198/4845
E-350 CUTAWAY DRW	4356/10,000 – 5670/12,500	3406/7510
E-450 CUTAWAY DRW	6373/14,050 – 6577/14,500	4073/8980

¹Properly equipped.



THE BIGGEST SELECTION OF VAN-BASED CUTAWAYS offers more choice and more capability with a new maximum GVWR of 6577 kg (14,500 lbs.). Continuously increasing capabilities and a Built Ford Tough® reputation have made E-Series Canada's best-selling line of van-based cutaways for 15 years in a row. Find out what possibilities they hold for your business.

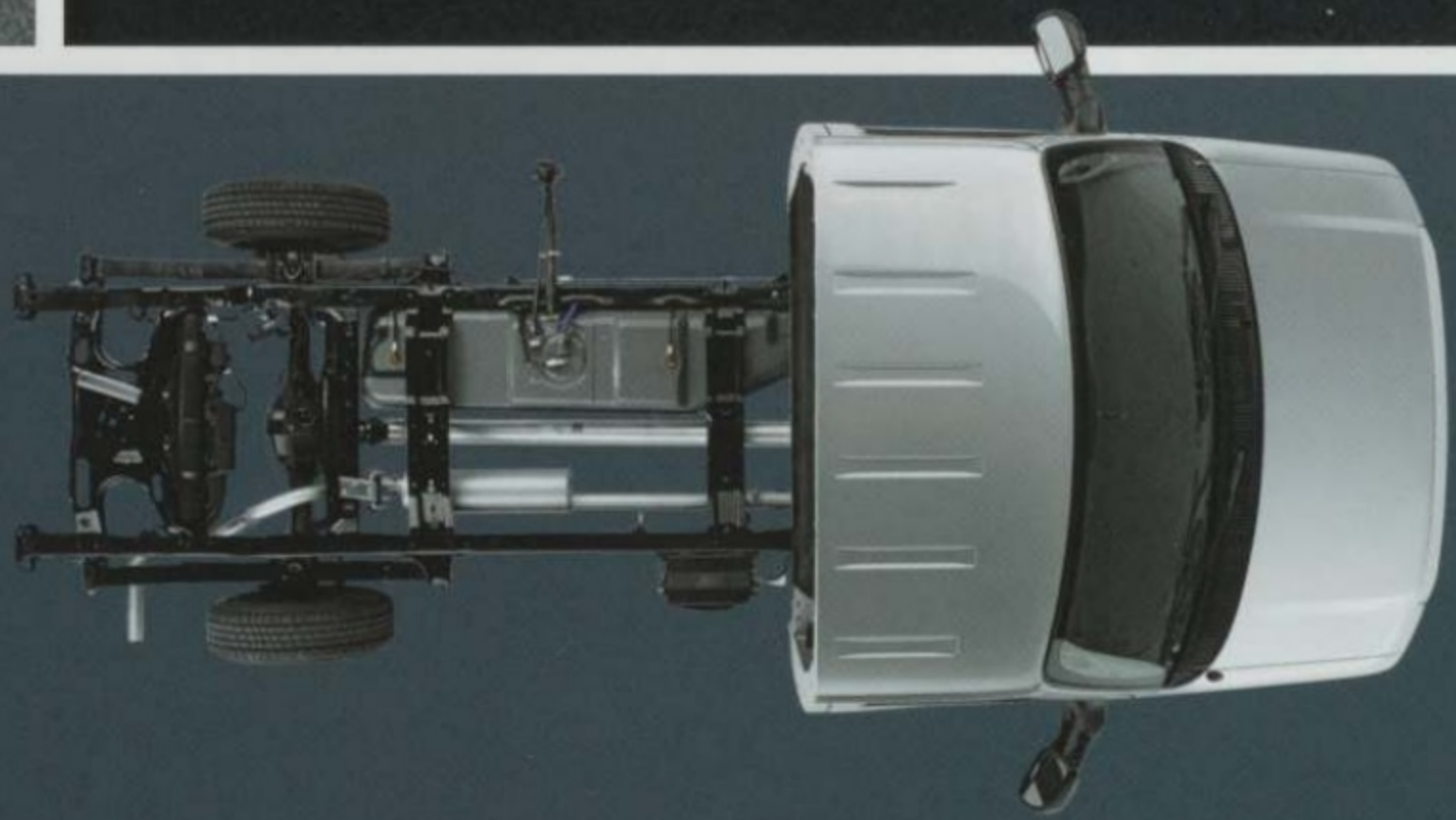

E-250 SUPER DUTY® CUTAWAY

A compact design and efficient 4.6L Triton® V8 offer you another choice in the E-Series Cutaway lineup. With its midship fuel tank location, you benefit from enhanced rear load capacity and added capability in an E-250 configuration.

E-350 SUPER DUTY CUTAWAY

E-350 is a supremely versatile heavy-duty cutaway, offering 3 powertrain choices as well as Ambulance, Motorhome, School Bus and Shuttle Bus Prep options. 158-in. and 176-in. wheelbase chassis are available with a class-leading 2268-kg (5000-lb.) front GAWR, and a GVWR increase to 5670 kg (12,500 lbs.).

E-450 SUPER DUTY CUTAWAY

For 2008, E-450 offers a standard 5.4L Triton V8. You can spec giant payloads (see chart above), and GCWRs up to 9072 kg (20,000 lbs.)² allow for outstanding towing capability. A new 2268-kg (5000-lb.) front GAWR is standard with an optional 6.8L Triton V10 or 6.0L Power Stroke® Turbo Diesel. An available 140-litre fuel tank provides more usable rear GAWR. An all-new 4-wheel brake system with ABS provides the power you need to help stop these huge loads.

²Properly equipped.

SPECIFICATIONS

DIMENSIONS



EXTERIOR mm (in.)	E-150 REGULAR LENGTH	E-250/E-350 SUPER DUTY ¹ REG. LENGTH	E-250/E-350 SUPER DUTY EXT. LENGTH
A. Overall length	5505 (216.7)	5505 (216.7)	6013 (236.7)
B. Wheelbase	3505 (138.0)	3505 (138.0)	3505 (138.0)
C. Loadfloor height	652 (25.7)	765 (30.1) (van) 697 (27.4) (wagon)	781 (30.7) (van) 798 (31.4) (wagon)
D. Overall width (without mirrors)	2016 (79.4)	2016 (79.4)	2016 (79.4)
Overall width (with mirrors)	2431 (95.7)	2692 (106.0) (van) 2431 (95.7) (wagon)	2692 (106.0) (van) 2431 (95.7) (wagon)
E. Overall height	2086 (82.1)	2126 (83.7) (van) 2118 (83.4) (wagon)	2148 (84.6)
Rear cargo door opening height	1189 (46.8)	1258 (49.5) (van) 1220 (48.0) (wagon)	1258 (49.5) (van) 1220 (48.0) (wagon)
Rear cargo door opening width	1381 (54.4)	1378 (54.3) (van) 1381 (54.4) (wagon)	1369 (53.9) (van) 1381 (54.4) (wagon)
Side cargo door opening height	1198 (47.2)	1225 (48.2) (van) 1198 (47.2) (wagon)	1221 (48.1) (van) 1198 (47.2) (wagon)
Swing-out side cargo door opening width	1138 (44.8)	1138 (44.8)	1138 (44.8)
Sliding side cargo door opening width	1006 (39.6)	1006 (39.6)	1006 (39.6)
INTERIOR mm (in.)			
1st Row			
Head room	1068 (42.0)	1068 (42.0)	1070 (42.1) (van) 1068 (42.0) (wagon)
Shoulder room	1729 (68.1)	1729 (68.1)	1729 (68.1)
Hip room	1664 (65.5)	1664 (65.5)	1664 (65.5)
Leg room	1015 (40.0)	1015 (40.0)	1015 (40.0)
2nd Row (Wagon)			
Head room	1020 (40.2)	1020 (40.2)	1020 (40.2)
Shoulder room	1822 (71.7)	1822 (71.7)	1822 (71.7)
Hip room	1688 (66.5)	1688 (66.5)	1688 (66.5)
Leg room	981 (38.6)	981 (38.6)	982 (38.7)
3rd Row (Wagon)			
Head room	1019 (40.1)	1019 (40.1)	1019 (40.1)
Shoulder room	1820 (71.7)	1820 (71.7)	1820 (71.7)
Hip room	1697 (66.8)	1697 (66.8)	1697 (66.8)
Leg room	1017 (40.0)	1017 (40.0)	1017 (40.0)
4th Row (Wagon)			
Head room	—	989 (38.9)	1006 (39.6)
Shoulder room	—	1763 (69.4)	1763 (69.4)
Hip room	—	1680 (66.1)	1680 (66.1)
Leg room	—	1001 (39.4)	1001 (39.4)
5th Row (Wagon)			
Head room	—	—	950 (37.4)
Shoulder room	—	—	1715 (67.5)
Hip room	—	—	1671 (65.8)
Leg room	—	—	939 (37.0)
Van Only			
Maximum cargo volume behind 1st row litres (cu. ft.)	6531 (230.6)	6531 (230.6)	7683 (271.3)

MAXIMUM LOADED TRAILER WEIGHT¹ kg (lbs.)

AUTOMATIC TRANSMISSION

WAGON	Engine	Axle Ratio	GCWR	E-150	E-350 SUPER DUTY	E-350 SUPER DUTY EXTENDED
4.6L SOHC V8	4.10	5443 (12,000)	2767 (6100)	—	—	—
				5.4L SOHC V8	3.55	5443 (12,000)
6.0L V8 Diesel	3.55	7257 (16,000)	—	3175 (7000)	3039 (6700)	2948 (6500)
				4.10	9072 (20,000)	—

VAN²

Engine	Axle Ratio	GCWR	E-150	E-250	E-250 EXTENDED	E-350 SUPER DUTY	E-350 SUPER DUTY EXTENDED							
4.6L SOHC V8	3.73	5216 (11,500)	2722 (6000)	2722 (6000)	2722 (5900)	—	—							
						4.10	5443 (12,000)	2948 (6500)	2948 (6500)	2902 (6400)	—	—		
5.4L SOHC V8	3.55	5443 (12,000)	2948 (6500)	—	—	—	—							
								3.73	5897 (13,000)	3402 (7500)	3402 (7500)	3311 (7300)	3357 (7400)	3266 (7200)
								4.10	5897 (13,000)	—	—	—	3357 (7400)	3266 (7200)
6.8L SOHC V10	3.73	6804 (15,000)	—	—	—	4173 (9200)	4082 (9000)							
						4.10	8391 (18,500)	—	—	—	4536 (10,000)	4536 (10,000)		
6.0L V8 Diesel	3.55	7257 (16,000)	—	—	—	4354 (9600)	4264 (9400)							
						4.10	9072 (20,000)	—	—	—	4536 (10,000)	4536 (10,000)		

CUTAWAY³

Engine	Axle Ratio	GCWR	E-250 SRW	E-350 SRW	E-350 DRW	E-450 DRW
4.6L SOHC V8	4.10	5443 (12,000)	3402 (7500)	—	—	—
5.4L SOHC V8	4.10	5897 (13,000)	—	3629 (8000)	3538 (7800)	—
						4.56
6.8L SOHC V10	4.10	8391 (18,500)	—	4536 (10,000)	4536 (10,000)	—
						4.56
6.0L V8 Diesel	4.10	9072 (20,000)	—	—	4536 (10,000)	4536 (10,000)

¹Maximum capabilities shown are for properly equipped vehicles with required equipment and a 68-kg (150-lb.) driver. Weight of additional options, equipment, passengers and cargo must be deducted from this weight. For additional information, see your Ford of Canada Dealer.
²For maximum trailer weights with crew van, deduct 90 kg (200 lbs.) from the weights above (except with 8391-kg [18,500-lb.] and 9072-kg [20,000-lb.] GCWRs).
³Cutaway ratings are based on incomplete vehicle. Final vehicle manufacturer weights and ratings will vary due to upfit and modification requirements.

FORD'S MOST RUGGED TRANSMISSION

Proven on Super Duty Chassis Cabs and Pickups, the available 5-speed automatic TorqShift[®] transmission is designed for the high-torque outputs of powerful E-Series engines. It's also improved for 2008 with an enhanced torque converter, as well as stronger low-end and overdrive gear sets. An innovative Tow/Haul Mode⁴ reduces gear hunting when towing and uses engine braking when descending steep grades.

⁴Tow/Haul Mode available with gas engine applications only.



ENGINES



6.0L POWER STROKE[®] V8 TURBO DIESEL⁵

This proven workhorse pumps out 235 hp and generates an impressive 440 lb.-ft. of torque. Its Electronic Variable Response Turbo (EVRT[®]) helps deliver low-speed response, plus steep-grade and high-altitude performance. Cast-iron block and heads withstand the combustion pressures of peak diesel operation. The robust design also features a stiffened bedplate which enhances durability and reduces noise, vibration and harshness (NVH). The Power Stroke is backed by a 5-year/160,000-km limited warranty⁶.

6.8L TRITON[®] V10

When the going gets tough, the tough opt for an available 6.8L Triton V10 (right) with best-in-class gas horsepower and torque. Its Electronic Throttle Control modulates torque at the drive wheels for smooth, seamless engine response.



4.6L/5.4L TRITON V8

Brawny Ford engines are at the heart of E-Series versatility and capability. E-Series is the only cargo van in its class to come with a standard V8: the 4.6L Triton. Every E-Series gas engine features a silent-design cam drive for smooth, quiet operation, plus a fail-safe cooling system. Step up to the 5.4L Triton V8 (left) to get extra punch for many high-capacity applications. Its proven SOHC architecture pumps out 255 hp and 350 lb.-ft. of torque across a wide powerband.



AVAILABLE ENGINE COMPARISONS

	4.6L SOHC TRITON V8	5.4L SOHC TRITON V8	6.8L SOHC TRITON V10	6.0L POWER STROKE V8 TURBO DIESEL ⁵
Horsepower (hp @ rpm)	225 @ 4800	255 @ 4500	305 @ 4250	235 @ 3300
Torque (lb.-ft. @ rpm)	286 @ 3500	350 @ 2500	420 @ 3250	440 @ 2000

⁵Late availability. ⁶See your Ford of Canada Dealer for details.

**E-SERIES WAGON
FEATURES & OPTIONS**

	E-150 XL	E-150 XLT	E-350 SUPER DUTY® XL	E-350 SUPER DUTY XLT
MECHANICAL				
● ● — —	4.6L Triton® V8 engine (4-speed automatic overdrive transmission)	5.4L Triton V8 engine (4-speed automatic overdrive transmission)	6.0L Power Stroke® V8 Turbo Diesel engine (5-speed TorqShift® automatic transmission; Regular Length only) ¹	AdvanceTrac® with RSC® (Roll Stability Control™) (requires 5.4L engine)
○ ○ ● ●	Alternator — 135-amp (5.4L engine only)	Daytime running lamps	Electronic Throttle Control (ETC)	Engine block heater
● ● ● ●	Engine oil cooler	Heavy-duty deep-cycle auxiliary battery (gas engines only)	Tire Pressure Monitoring System (excludes spare)	Traction Control
○ ○ ○ ○	Trailer Tow Package — Class II/III/IV			
SAFETY/SECURITY				
● ● ● ●	Airbags ² — Driver and front-passenger front	Belt-Minder® safety belt reminder	Power 4-wheel disc brakes with Anti-lock Brake System (ABS)	Remote keyless-entry system with panic alarm and illuminated entry (requires Power Equipment Group)
○ ○ ○ ○	SecuriLock® passive anti-theft engine immobilizer system			
SEATING				
— ○ — —	7 passengers: (4) leather-trimmed captain's chairs for 1st and 2nd rows; (1) 3-passenger rear bench seat (requires XLT Premium Package)	● — — —	8 passengers: (2) front bucket seats; (2) 3-passenger rear bench seats	— ● — —
— ● — —	8 passengers: (2) front captain's chairs; (2) 3-passenger rear bench seats	— — ○ ○	11 passengers: (2) front bucket seats; (3) 3-passenger rear bench seats (Extended Length only)	— — ● —
— — ● —	12 passengers: (2) front bucket seats; (2) 3-passenger rear bench seats; (1) 4-passenger rear bench seat	— — ● ●	12 passengers: (2) front captain's chairs; (2) 3-passenger rear bench seats; (1) 4-passenger rear bench seat	— — ● —
— — ● —	15 passengers: (2) front bucket seats; (3) 3-passenger rear bench seats; (1) 4-passenger rear bench seat (Extended Length only)	— — ● ●	15 passengers: (2) front captain's chairs; (3) 3-passenger rear bench seats; (1) 4-passenger rear bench seat (Extended Length only)	— ○ — ○
— ○ — ○	Power driver seat — 6-way with manual lumbar	● — ● —	Vinyl seating (Fleet only)	○ ● ○ ●
○ ● ○ ●	Cloth seating			
APPEARANCE/COMFORT/CONVENIENCE				
● ● ● ●	Air conditioning (front only)	○ ● ○ ●	Air conditioning — High-capacity (front and rear; standard on XL Extended Length)	AM/FM stereo with digital clock and 4 speakers
○ ● ○ ●	AM/FM stereo/single-CD player with digital clock and 4 speakers (XL); 6 speakers (XLT)	— ○ — ○	Premium Plus Sound System — AM/FM stereo/6-disc in-dash CD changer with digital clock and 6 speakers	● — ● —
● — ● —	Bumpers — Front and rear, Black-painted	● ● ● ●	Bumpers — Front and rear contour, chrome	○ ○ ○ ○
○ ○ ○ ○	Bumper — Rear step, chrome (requires Exterior Upgrade Package on XL)	○ — ○ —	Bumper — Rear step, Black-painted (n/a with Exterior Upgrade Package)	○ ● ○ ●
○ ● ○ ●	Cruise control	● ● ● ●	Engine cover console — Slim-line	○ ○ ○ ○
○ ○ ○ ○	Engine cover console — Deluxe with storage and 4 cupholders	○ ○ ○ ○	Floor covering — Full-length vinyl	○ ● ○ ●
○ ● ○ ●	Floor covering — Full-length carpet	○ ● ○ ●	Floor mats — Carpeted	● — ● —
● — ● —	Mirrors — Manual-adjustable sideview	— ● — ●	Mirrors — Power-adjustable sideview	— ○ — ○
— ○ — ○	Mirrors — Telescoping trailer tow, manual-adjustable sideview	○ ○ ○ ○	Overhead console	● ● ● ●
○ ○ ○ ○	Power Windows and Locks Group	○ ○ ○ ○	Privacy glass	○ ○ ○ ○
○ ○ ○ ○	Reverse Sensing System	○ ○ ○ ○	Running boards	○ ○ ○ ○
○ ○ ○ ○	Side cargo door — Sliding solid panel	● ● ● ●	Tilt steering wheel	● ● ● ●
● ● ● ●	Visors — Cloth; illuminated with driver map strap on XLT			
PACKAGES				
○ — ○ —	Exterior Upgrade Package — Includes chrome bumpers and grille surround, and aerodynamic halogen headlamps	— ○ — —	XLT Premium Package — 7 passengers; includes leather captain's chairs for 1st and 2nd rows, power driver seat, remote keyless entry, leather-wrapped steering wheel, privacy glass, overhead console, special two-tone exterior paint, forged-aluminum wheels, and running boards	

● Standard ○ Select Availability ○ Optional — Not Available
¹Late availability. ²Always wear your safety belt and secure children in the rear seat.

**E-SERIES CUTAWAY/STRIPPED CHASSIS
FEATURES & OPTIONS**

	E-250 SUPER DUTY CUTAWAY	E-350 SUPER DUTY CUTAWAY	E-450 SUPER DUTY CUTAWAY	E-350 SUPER DUTY STRIPPED CHASSIS	E-450 SUPER DUTY STRIPPED CHASSIS
MECHANICAL					
● — — —	4.6L Triton V8 engine	5.4L Triton V8 engine	6.8L Triton V10 engine	6.0L Power Stroke V8 Turbo Diesel engine ¹	4-speed automatic transmission
— ● ● ●	5-speed automatic TorqShift transmission with overdrive and Tow/Haul Mode (5.4L and 6.8L engines only)	5-speed automatic TorqShift transmission with overdrive (diesel engine only)	Alternator — 135-amp (5.4L and 6.8L engines only)	Alternator — 140-amp (diesel engine only)	Alternator — Dual-system 140/120 (diesel engine only)
— ○ ○ ○	Auxiliary fuel port	Daytime running lamps	Electronic Throttle Control (ETC)	Engine block heater	Fuel tank capacity — 132.5-litre midship
● ● ● ●	Fuel tank capacity — 140-litre aft of axle	Fuel tank capacity — 208-litre aft of axle	Heavy-duty deep-cycle auxiliary battery (gas engines only)	Spare tire and wheel	Steering gear — Heavy-duty
○ ○ ○ ○	Traction Control (gas engines only)				
SAFETY/SECURITY					
● ● ● —	Airbags ² — Driver and front-passenger front	● ● ● —	Belt-Minder safety belt reminder	● ● ● ●	Power 4-wheel disc brakes with Anti-lock Brake System (ABS)
○ ○ ○ —	Remote keyless-entry system ³	● ● ● ●	SecuriLock passive anti-theft engine immobilizer system (SRW only)	● ● ● ●	Tire Pressure Monitoring System (SRW only) (excludes spare)
SEATING					
— ○ ○ —	Captain's chair — Cloth, driver side only	— ○ ○ —	Captain's chair — Without trim, driver side only	● ● ● —	Dual vinyl bucket seats
○ ○ ○ —	Dual cloth bucket seats	○ ○ ○ —	Dual cloth captain's chairs	— ○ ○ —	Dual captain's chairs — Without trim
— ○ ○ —	Power driver seat — 6-way (requires captain's chair)	— ○ ○ —	Manual Seat Prep Package	— ○ ○ —	Power Seat Prep Package
— ○ ○ —	Manual pedestal with 2-way adjuster	— — — ●	Seats not included (no pedestal)		
APPEARANCE/COMFORT/CONVENIENCE					
● ● ● —	Air conditioning (front)	○ ○ ○ —	Air conditioning delete	● ● ● —	AM/FM stereo with digital clock
○ ○ ○ —	Premium AM/FM stereo/single-CD player and digital clock	○ ○ ○ —	Premium Plus Sound System — AM/FM stereo/6-disc in-dash CD changer and digital clock	○ ○ ○ ●	Radio delete
○ ○ ○ —	Radio Prep Package	● ● ● —	Bumper — Front, black-painted	○ ○ ○ —	Bumper — Front, white-painted
○ ○ ○ —	Cruise control	○ ○ ○ —	Engine cover console — Slim-line	○ ○ ○ —	Engine cover console — Deluxe with storage and 4 cupholders
— ○ ○ —	Frame spacers — Alternate lateral	— ○ ○ —	Frame spacers — Standard pattern	○ ○ ○ —	Mirror — Interior day/night rearview
○ ○ ○ —	Mirrors — Aerotype manual sideview	○ ○ ○ —	Mirrors — Telescoping trailer tow, manual-adjustable sideview	○ ○ ○ —	Mirrors — Telescoping trailer tow, power-adjustable sideview ³
○ ○ ○ —	Modified vehicle wiring kit and system	○ ○ ○ —	Power Windows and Locks Group	○ ○ ○ —	Pucks — Frame isolator
— ○ ○ —	Right-hand door delete	● ● ● ●	Tilt steering wheel	● ● ● ●	Windshield wipers — Interval (controls only, no wiper motor on Stripped Chassis)

¹Requires Power Windows and Locks Group. ²Restrictions apply, see dealer for details.

**E-SERIES CUTAWAY/STRIPPED CHASSIS
PACKAGES⁴**

	E-250 SUPER DUTY CUTAWAY	E-350 SUPER DUTY CUTAWAY	E-450 SUPER DUTY CUTAWAY	E-350 SUPER DUTY STRIPPED CHASSIS	E-450 SUPER DUTY STRIPPED CHASSIS
— — — ○	AC Prep Package — Scroll compressor, condenser, drive belt, tensioner attaching brackets and bolts	— ○ ○ —	Ambulance Prep Package — Auxiliary Heater/AC Connector Package, 4:10:1 limited-slip axle (E-350), dual alternators, front licence plate bracket, manual telescoping trailer tow mirrors, spare tire and wheel, frame pucks, dual-note horn (requires diesel engine)	— ○ ○ —	Auxiliary Heater/Air Conditioning Connector Package — Front heater connector and front air conditioning connector
— ○ ○ —	Auxiliary Heater/Air Conditioning Connector Package w/Rear Controls	— ○ ○ —	Class I Trailer Tow Prep Package	— ○ ○ —	Exterior Upgrade Package — Front chrome bumper and grille, and aerodynamic headlamps
— ○ ○ —	Handling Package — Front stabilizer bar and heavy-duty front and rear shock absorbers	● ● ● ●	Insulation Package — Front cloth headliner and cloth sun visors	○ ○ ○ —	Interior Upgrade Package — Front cloth headliner, high-series door-trim panels, dual cloth captain's chairs, cloth sun visors, carpet, power windows/door locks, and Insulation Package
— ○ ○ —	Motorhome Prep Package — Front chrome bumper and grille, aerodynamic headlamps, power windows/door locks, manual pedestals (seats not included), Class I Trailer Tow Prep Package, cruise control, frame pucks, 2-speaker Radio Prep Package, front licence plate bracket, and 208-litre fuel tank (140-litre with E-350 Super Duty with 3505-mm [138"] or 4470-mm [176"] WB)	— ● ● —	School Bus Prep Package — Front licence plate bracket, banded front door glass (tinted), high-back driver seat only, frame pucks; deletes RH seat, RH seat pedestal and attaching hardware, RH safety belt system, RH B-pillar trim and scuff plate, passenger-side front airbag, sideview mirrors and front headliner	— ○ ○ —	Shuttle Bus Prep Package — Front chrome bumper and grille, aerodynamic headlamps, manual pedestals (seats not included), frame pucks, power windows/door locks, front licence plate bracket, engine block heater, driver and front-passenger front airbags; deletes front headliner and front dome lamp

E-SERIES VAN FEATURES & OPTIONS

E-150 COMMERCIAL	
E-250 COMMERCIAL	
E-350 SUPER DUTY [®] COMMERCIAL	
MECHANICAL	
● ● —	4.6L Triton [®] V8 engine
○ ○ ●	5.4L Triton V8 engine
— — ○	6.0L Power Stroke [®] V8 Turbo Diesel engine ¹
— — ○	6.8L Triton V10 engine
● ● ●	4-speed automatic overdrive transmission
— — ○	5-speed automatic TorqShift [®] transmission with overdrive and Tow/Haul Mode (requires 6.8L engine)
— — ○	5-speed automatic TorqShift transmission with overdrive (requires 6.0L)
○ ○ ○	Alternator — 135-amp (5.4L and 6.8L engines only)
— — ○	Alternator — 140-amp (diesel engine only)
— — ○	Alternator — Dual-system 140/120 (diesel engine only)
○ ○ ○	Auxiliary fuel port ²
● ● ●	Daytime running lamps
● ● ●	Electronic Throttle Control (ETC)
● ● ●	Engine block heater
— ○ ○	Front GAWR — One-up ³
○ ○ ○	Heavy-duty deep-cycle auxiliary battery (gas engines only)
○ ○ ○	Traction Control (gas engines only)
SAFETY/SECURITY	
● ● ●	Airbags ⁴ — Driver and front-passenger front
● ● ●	Belt-Minder [®] safety belt reminder
● ● ●	E-Guard Cargo Protection System [™]
● ● ●	Power 4-wheel disc brakes with Anti-lock Brake System (ABS)
● ● ●	SecuriLock [®] passive anti-theft engine immobilizer system
● ● ●	Tire Pressure Monitoring System (excludes spare)
SEATING	
● ● ●	Dual vinyl bucket seats
○ ○ ○	Dual cloth bucket seats
○ ○ ○	Dual cloth captain's chairs ⁵
○ ○ ○	Power driver seat — 6-way (requires captain's chairs)
APPEARANCE/COMFORT/CONVENIENCE	
● ● ●	Air conditioning (front only)
○ ○ ○	Air conditioning — High-capacity (front and rear)
● ● ●	AM/FM stereo with digital clock
○ ○ ○	AM/FM stereo/single-CD player with digital clock
○ ○ ○	Premium Plus Sound System — AM/FM stereo/6-disc in-dash CD changer with digital clock and 6 speakers
○ ○ ○	Radio delete
● ● ●	Bumpers — Front and rear contour, Black-painted
● ● ●	Bumpers — Front and rear contour, chrome
● ● ●	Bumper — Rear step, chrome
● ● ●	Bumper — Rear step, Black-painted
○ ○ ○	Cruise control
○ ○ ○	Engine cover console — Deluxe with storage and 4 cupholders
○ ○ ○	Floor covering — Front and rear vinyl
● ● ●	Light and Convenience Group — Includes courtesy light switches on all doors, warning chime and headlamps-on alert chime
● ● ●	Mirrors — Aero-style, power-adjustable sideview ⁶
● ● ●	Mirrors — Telescoping trailer tow, manual-adjustable sideview
○ ○ ○	Mirrors — Telescoping trailer tow, power-adjustable sideview ⁷
○ ○ ○	Power Group (door locks, windows, sideview mirrors, remote keyless-entry system)
○ ○ ○	Privacy glass ⁸
○ ○ ○	Reverse Sensing System (requires rear step or contour bumper)
○ ○ ○	Running boards
○ ○ ○	Side cargo door — Sliding solid panel
● ● ●	Side cargo doors — Swing-out 60/40 split
○ ○ ○	Windows — Fixed rear cargo door glass
○ ○ ○	Windows — Fixed side/fixed rear cargo door glass
○ ○ ○	Windows — Swing-out side/fixed rear cargo door glass
○ ○ ○	Windows — All-around (includes swing-out side/fixed rear cargo door glass)

● Standard ● Select Availability ○ Optional — Not Available

E-SERIES VAN PACKAGES⁹

E-150 COMMERCIAL	
E-250 COMMERCIAL	
E-350 SUPER DUTY [®] COMMERCIAL	
— — ○	Ambulance Prep Package — Auxiliary heater/AC Connector, 4.10:1 limited-slip axle, dual alternators, dual-note horn, floor pan extended side and rear, fixed side/rear door tinted glass, front vinyl headliner with HIC extension, maximum front GAWR, modified vehicle wiring kit, and vinyl sun visors
○ ○ ○	Commercial Value Package⁷ — Reverse Sensing System, rear step bumper (Black), Power Group, and fixed rear glass
○ ○ ○	Crew Van Interior Upgrade Package — 2nd-row cloth bench seat, full-length carpeting, dual cloth captain's chairs, cloth sun visors, carpeted floor mats, dash sound absorbers, full-length cloth headliner and Power Group
○ ○ ○	Crew Van Package — 2nd-row vinyl bench seat, metal-mesh bulkhead, partial headliner, full B-pillar trim panels, low-series (polypropylene) side door and back door-trim panels, LH lower trim panel behind driver seat, restraints with metal retractor cover for 2nd-row bench seat, pull handle on 40% side door and RH back door
○ ○ ○	Dome/Cargo Light Kit — 3 additional cargo lights
○ ○ ○	Exterior Upgrade Package — Front and rear contour chrome bumpers, chrome grille surround, aerodynamic halogen headlamps, and optional aluminum wheels (requires gas engine)
● ● ●	Handling Package — Front stabilizer bar, heavy-duty front and rear shock absorbers
○ ○ ○	Insulation Package — Full-length headliner, cloth sun visors, upper B-pillar trim panels, polypropylene side door and rear trim panels
○ ○ ○	Interior Upgrade Package — Full-length carpeting, side/rear cargo door-trim panels, dash sound absorber, full-length headliner, cloth sun visors, full B-pillar trim, dual cloth captain's chairs, front carpeted floor mats, Insulation Package ⁶ and Power Group
○ ○ ○	Premium Van Package — Dual captain's chairs, AM/FM stereo/single-CD player with digital clock, Exterior Upgrade Package, Power Group, cruise control, and Insulation Package
○ ○ ○	Trailer Tow Package — Class II/III/IV — Trailer wiring harness (blade-style female connector), electric brake controller tap-in capability, relay system for backup/B+/running lights, and frame-mounted hitch receiver

¹Late availability. ²Standard on diesel, optional on gas. Not available with 4.6L or E-150/E-250 Vans. ³Computer selected. ⁴Always wear your safety belt and secure children in the rear seat if equipped. ⁵Available as part of Interior Upgrade Package. ⁶Included as part of Power Group. ⁷Requires Power Group. ⁸Restrictions apply, see dealer for details.

Our commitment to you... Peace-of-Mind Protection

- Basic Coverage: 3 years/60,000 km
- Powertrain Limited Warranty: 5 years/100,000 km
- Direct-Injection Diesel Engine: 5 years/160,000 km (if equipped)
- Corrosion Warranty: 5 years/unlimited distance
- Roadside Assistance: 5 years/100,000 km⁹

Certain conditions apply. For more information on these warranties and coverages, ask your local Ford of Canada Dealer or visit www.ford.ca. *No additional cost.

For more information on Ford of Canada and Ford products, please visit our website:

ford.ca
or fleet.ford.ca

For prompt, courteous answers to your questions:

Ford Customer Relationship Centre
1-800-565-3673
Ford Credit Customer Service Centre
1-877-636-7346

Competitive comparisons are based on 2007 competitive models, publicly available information and Ford data at the time of printing. Some features discussed may be optional. Vehicles shown may contain optional equipment and aftermarket upfits. Features shown may be offered only in combination with other options or subject to additional ordering requirements or limitations. Dimensions and capacity ratings shown may vary due to optional features and/or production variability. Following publication of this catalogue, certain changes in standard equipment, options and the like, or product delays may have occurred which would not be included in these pages. Your Ford of Canada Dealer is your best source for up-to-date information. Ford Motor Company of Canada, Limited, reserves the right to change product specifications at any time without incurring obligations. Colours may not be exactly as illustrated due to restrictions of the printing process. Please see your sales consultant for specific colour and model availability. Body Manufacturers are responsible for compliance certification of the completed vehicle. The Ford New Truck Limited Warranty and any government certification made by Ford shall cover only the vehicle as manufactured by Ford and shall not extend to any addition, modification or change of or to the vehicle by the Ford Authorized Pool Account.

EXTERIOR COLOURS



Oxford White



Pueblo Gold Metallic



Yellow



Dark Toreador Red Metallic



Forest Green Metallic



Dark Blue Pearl Metallic



Silver Metallic



Dark Shadow Grey Metallic



Black



Vermillion Red

INTERIOR COLOURS



Premium Medium Pebble Cloth



Medium Flint Cloth

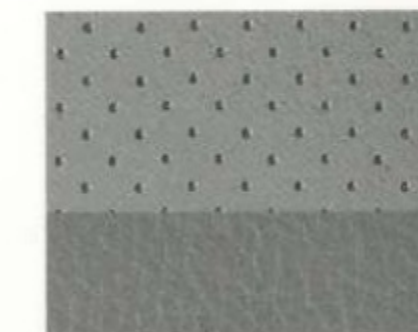

Medium Flint Vinyl



Medium Pebble Leather



Premium Medium Flint Cloth



Medium Flint Leather

MEDIUM PEBBLE

MEDIUM FLINT

XL/XLT WAGON¹⁰

- ● Oxford White
- ● Pueblo Gold Metallic
- ● Yellow (XL only) (Fleet only)
- ● Dark Toreador Red Metallic
- ● Forest Green Metallic
- ● Dark Blue Pearl Metallic
- ● Silver Metallic
- ● Dark Shadow Grey Metallic
- ● Black
- ● Vermillion Red

XLT PREMIUM

- ● Oxford White/Silver Metallic Two-Tone
- ● Oxford White/Dark Shadow Grey Metallic Two-Tone
- ● Pueblo Gold Metallic/Dark Shadow Grey Metallic Two-Tone
- ● Dark Toreador Red Metallic/Silver Metallic Two-Tone
- ● Dark Toreador Red Metallic/Dark Shadow Grey Metallic Two-Tone
- ● Forest Green Metallic/Dark Shadow Grey Metallic Two-Tone
- ● Dark Blue Pearl Metallic/Silver Metallic Two-Tone
- ● Black/Silver Metallic Two-Tone
- ● Black/Dark Shadow Grey Metallic Two-Tone

VAN¹¹

- ● Oxford White
- ● Pueblo Gold Metallic
- ● Yellow
- ● Dark Toreador Red Metallic
- ● Forest Green Metallic
- ● Dark Blue Pearl Metallic
- ● Silver Metallic
- ● Dark Shadow Grey Metallic
- ● Black
- ● Vermillion Red (Fleet only)

CUTAWAY

- ● Oxford White
- ● Yellow (Fleet only)
- ● Dark Toreador Red Metallic
- ● Dark Blue Pearl Metallic
- ● Silver Metallic
- ● Black
- ● Vermillion Red (Fleet only)

¹⁰Medium Pebble available on XLT only.

¹¹Medium Pebble requires Interior Upgrade Package.

Ford uses clearcoat paint for beauty and protection. Colours shown are representative only. Not all colours are available on all models. See your dealer for actual paint/trim options.

WHEELS



16" Full Sport Wheel Cover
Standard on Van and Wagon



16" Forged-Aluminum
Optional on Van and Wagon

The Right Ford Truck for You

Ford's full line of trucks can handle any job thrown at them. F-Series pickup trucks continue to outsell any other line of pickup trucks, 41 years running. In addition to the Built Ford Tough® F-350/F-450/F-550 Super Duty® Chassis Cabs, for really big jobs, choose an F-650 or F-750. In tight spaces, Ford LCF delivers with ease. And E-Series, the Full-Size Van sales leader for 15 years running, can carry people, cargo or even specialized vehicle bodies for virtually any vocation. Your Ford of Canada Dealer can help you select a great truck to suit your business objectives today.

Visit ford.ca to find your perfect match.



Ford Super Duty Chassis Cab



Ford F-650/F-750



Ford LCF



Ford E-Series

For more information on Ford of Canada products and services, please visit our website:

