

**AMERICA'S  
NEW BREED OF  
WORKHORSE**

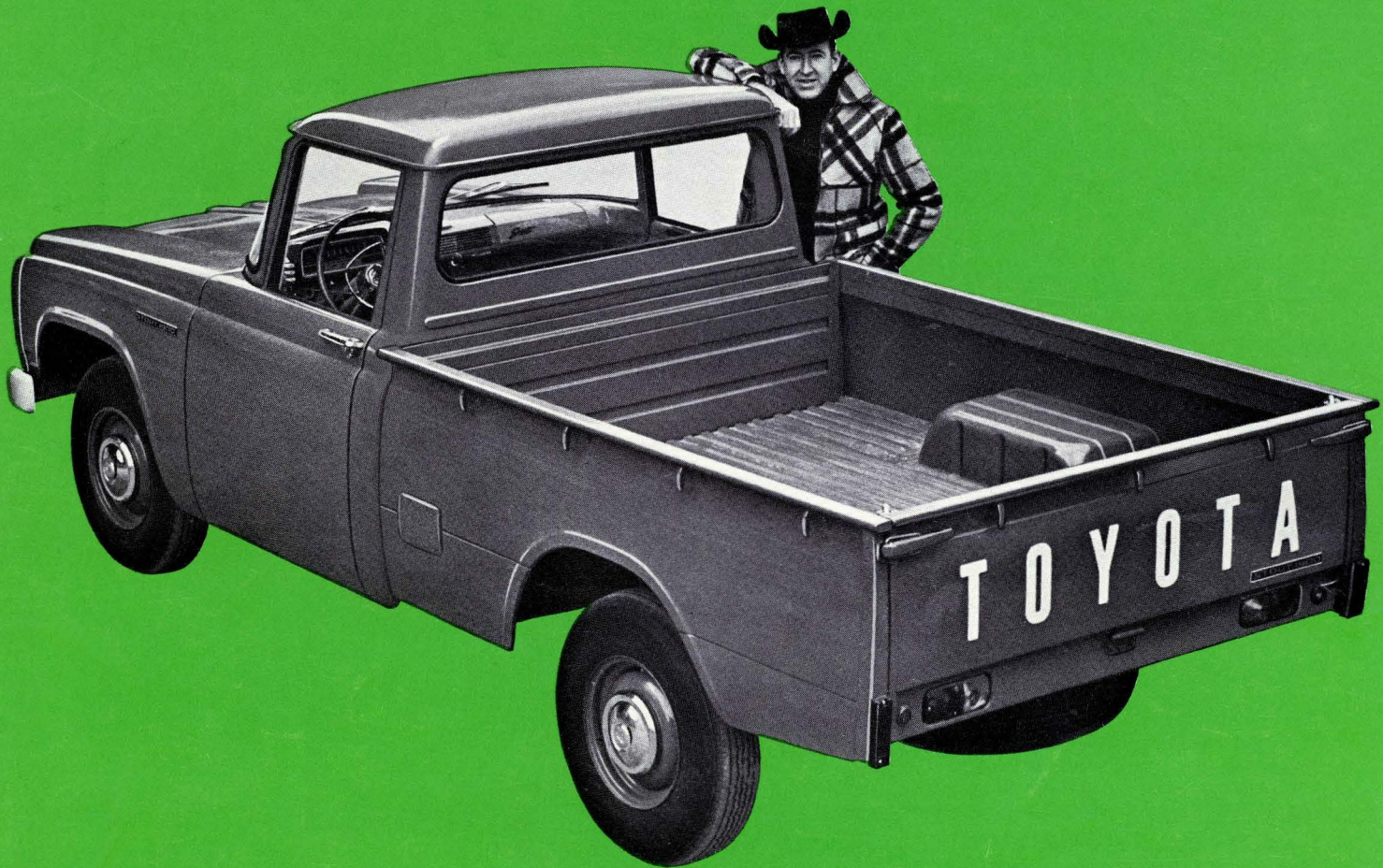

**TOYOTA STOUT 1/2 TON PICKUP**  
**With 4 Speed Transmission**



**HAULS FULL 2,000 LB. LOADS [TWICE ITS RATED LOAD]  
CRUISES AND HANDLES LIKE  
A PLEASURE CAR**

Willing workhorse—speedy road-runner—in town and cross country—that's the new TOYOTA Stout 1/2 TON PICKUP. This tough TOYOTA Pickup introduces a new breed of truck that gets its extra strength, zip and hauling power from Toyota's 1900 cc high performance engine—plus a 4-speed synchromesh transmission that gears to any load and road.

Rugged as it is, the new TOYOTA Stout Pickup works both ways—trucks ton loads on the job—and cruises and handles like a passenger car. Built on a solid girder frame, with extra heavy duty rear axle and suspension, the TOYOTA takes punishment that lighter, smaller pickups can't take. Its large box is a full 6 ft. x 5 ft. Cargo deck and walls are reinforced for maximum strength. And the flat tailgate, with snap latches, permits loading beyond the bed. Tie-down hooks all around add to the bulk carrying capacity.

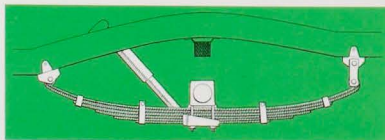
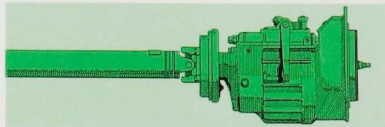
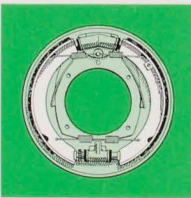

**Cruising Comfort—  
Operating Economy**

TOYOTA'S new breed of pickup also introduces a new high in driving comfort. The cab is big, roomy, weather-tight. Three men can ride in deep, pleated foam cushion comfort—with driver's seat adjustable. The 4-speed gearshift is column-mounted leaving the floor clear, with plenty of legroom. Oversize, twin-cylinder hydraulic brakes assure safe, smooth stops.

With all its muscle and hauling capacity, the TOYOTA Stout is amazingly economical. Owners report excellent mileage in both business and sports use. From initial cost, through upkeep and resale—there's no greater moneymaking pickup on the market for large fleet operator or individual truck owner than the new TOYOTA Stout 1/2 Ton Pickup.

# Specifications

**ENGINE:** 4 cyl. in line OHV  
 Bore and stroke: 3.46 x 3.07 inches  
 Displacement: 115.7 cubic inches  
 Compression ratio: 7.7:1  
 Maximum horsepower: 85 @ 4600 rpm  
 Maximum torque: 110 ft. lb. @ 2600 rpm  
 Carburetor: Down draft 2 barrel  
 Fuel tank capacity: 10.6 U.S. gallons  
 Cooling system: 8.4 quarts  
 Crankcase capacity: 4.7 quarts  
 Battery: 12 volt 59 amp hour  
 Generator: 12 volt 240 W.

**CLUTCH:** Dry single plate with torsion rubbers  
 Facing diameter: 7.9 inches  
 Facing area: 50 square inches

**TRANSMISSION** 4 speed, synchromesh  
 2nd, 3rd and 4th

**REAR AXLE:** Semi-floating hypoid  
 Ratio: 4.875:1

**TIRES:** 7.50 x 14, 4-ply

**SUSPENSION:** Front: Coil spring, hydraulic shock absorbers.  
 Rear: Leaf spring, hydraulic shock absorbers.

**STEERING:** Recirculating ball type  
 Gear ratio: 18:1  
 Turning radius: 20 feet

**BRAKES:** Hydraulic, 4 wheels  
 Braking surface: 132.5 square inches

**PERFORMANCE:**  
 Maximum Speed: 80 mph

**DIMENSIONS AND WEIGHT:**  
 Overall length: 170 inches  
 Overall width: 66.7 inches  
 Overall height: 64.6 inches  
 Wheelbase: 104.5 inches  
 Tread: Front: 52.6 inches  
 Rear: 53.2 inches  
 Curb weight: 2830 lbs.  
 Load capacity: ½ ton rating

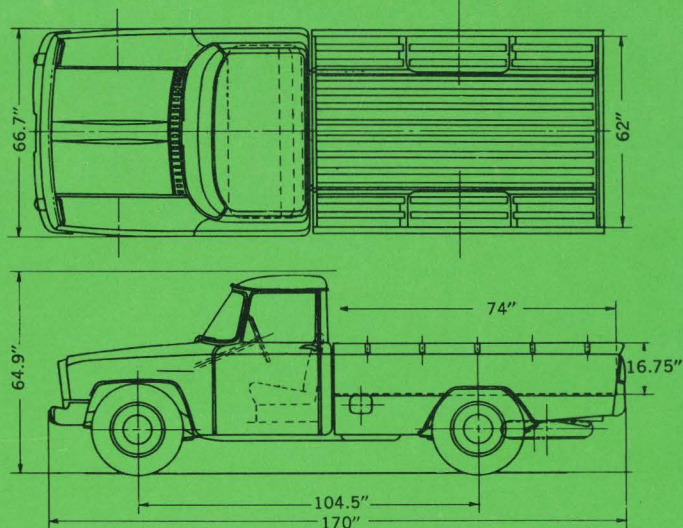

**TOYOTA CAMPER** Removable for Weekday Work—Weekend Pleasure! When the workday week is over, head for the high country and the camping pleasures waiting! This super-strong Camper, specially designed for the Toyota Stout ½ Ton

Pickup, is top-quality engineered. Constructed of all-weather aluminum, with full door for easy entry—well insulated and vented—the Toyota Camper combines maximum ruggedness with camping comfort at an amazing price.



*The Toyota policy of continual improvement in design and manufacture requires specifications equipment and prices be subject to change without notice.*

**TOYOTA MOTOR DISTRIBUTORS, INC., Western Division**  
 5858 Hollywood Blvd., Los Angeles, California 90028

**MID-SOUTHERN TOYOTA LTD.**  
 7744 S. Stony Island Avenue, Chicago, Illinois 60649

**TOYOTA MOTOR DISTRIBUTORS, INC., Eastern Division**  
 231 Johnson Avenue, Newark, New Jersey 01708

## Specifications

**ENGINE:** 4 cyl. in line OHV  
 Bore and stroke: 3.46 x 3.07 inches  
 Displacement: 115.7 cubic inches  
 Compression ratio: 7.7:1  
 Maximum horsepower: 85 @ 4600 rpm  
 Maximum torque: 110 ft. lb. @ 2600 rpm  
 Carburetor: Down draft 2-barrel  
 Fuel tank capacity: 10.6 U.S. gallons  
 Cooling system: 8.4 quarts  
 Crankcase capacity: 4.7 quarts  
 Battery: 12 volt 59 amp-hour  
 Generator:

**CLUTCH:** Dry single plate with torsion rubbers  
 Facing diameter: 7.9 inches  
 Facing area: 50 square inches

**TRANSMISSION** 4 speed, synchromesh  
 2nd, 3rd and 4th

**REAR AXLE:** Semi-floating hypoid  
 Ratio: 4.875:1

**TIRES:** 7.50 x 14, 4-ply

**SUSPENSION:** Front: Coil spring, hydraulic shock absorbers.  
 Rear: Leaf spring, hydraulic shock absorbers.

**STEERING:** Recirculating ball type  
 Gear ratio: 18:1  
 Turning radius: 20 feet

**BRAKES:** Hydraulic, 4 wheels  
 Braking surface: 132.5 square inches

**PERFORMANCE:** Maximum Speed: 80 mph

**DIMENSIONS AND WEIGHT:**  
 Overall length: 170 inches  
 Overall width: 66.7 inches  
 Overall height: 64.6 inches  
 Wheelbase: 104.5 inches  
 Tread: Front: 52.6 inches  
 Rear: 53.2 inches  
 Curb weight: 2830 lbs.  
 Load capacity: 1/2 ton rating

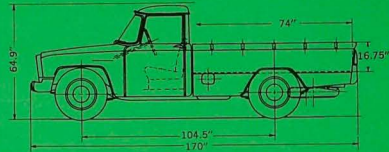
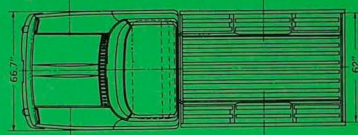

**TOYOTA CAMPER** Removable for Weekday Work—Weekend Pleasure! When the workday week is over, head for the high country and the camping pleasures waiting! This super-strong Camper, specially designed for the Toyota Stout 1/2 Ton

Pickup, is top-quality engineered. Constructed of all-weather aluminum, with full door for easy entry—well insulated and vented—the Toyota Camper combines maximum ruggedness with camping comfort at an amazing price.



The Toyota policy of continual improvement in design and manufacture requires specifications equipment and prices be subject to change without notice.

**TOYOTA MOTOR DISTRIBUTORS, INC.**, Western Division  
 5858 Hollywood Blvd., Los Angeles, California 90028  
**MID-SOUTHERN TOYOTA LTD.**  
 7744 S. Stony Island Avenue, Chicago, Illinois 60649  
**TOYOTA MOTOR DISTRIBUTORS, INC.**, Eastern Division  
 231 Johnson Avenue, Newark, New Jersey 07106

# AMERICA'S NEW BREED OF WORKHORSE



**TOYOTA STOUT 1/2 TON PICKUP**  
**With 4 Speed Transmission**