

NEW  
13½ CWT

# HOLDENS

Bigger all round!  
Stronger all through!





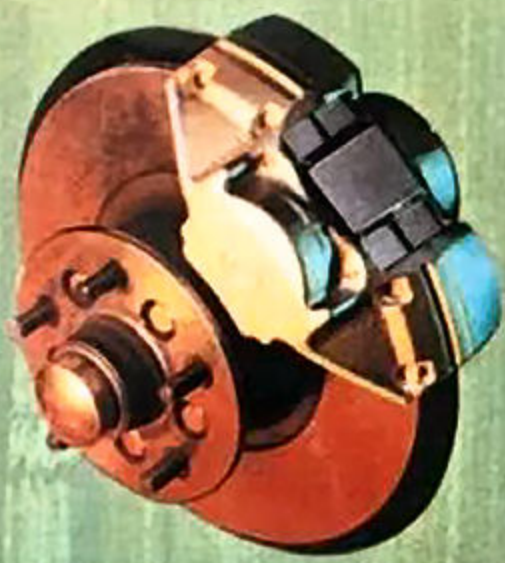

*You can order front wheel disc brakes ...*



*contoured bucket seats for peak driving comfort ...*



*sports wheel discs for an exciting GT look ...*



*or Holden's new 5-litre V8 that puts 210 high-spirited horses under your toe.*



# HOLDEN KINGSWOOD UTILITY

Dashing new blend of brawn and beauty!

With new 13½ cwt workpower! New comfort inside!

And all the luxury you care to order!

## Who says work and play don't mix!

The new Kingswood Utility leads a double life. It's handsome, spirited, ready to go with the crowd. That longer, lower styling, those sleek and beautifully proportioned lines would be right at home in any company. But when there's work to be done, Kingswood, like its Belmont brother, is all business. We've made it bigger and stronger, put more beef into the suspension to cope with loads right up to 13½ cwt. (3½ more than before). And with a choice of 4 great engines up to a 210 hp 5-litre V8, you can power your Kingswood for just the kind of work, or play, you have in mind.

## Tray area is longer, wider, deeper

In all three dimensions, Holden's new cargo area is bigger than before. The depth has been increased to 16.7 ins. The length to 80.6 ins. And the width to 57.8 ins. (or 44.8 ins. between wheel arches). All this adds up to a substantial increase in the bulk, as well as weight, of the cargo you can carry. Another point: the extra width is not just at floor level, but all the way up. So it's fully usable with every kind of load.

## Bigger wheels! Huskier suspension!

Holden's new heavy-duty wheels are up in size from 13" to 14". They take bigger tyres, 6.95 x 14-6 ply low profile; or 7.35 x 14 can be fitted if you wish. Increased rate springs are fitted. Shock absorbers are heavier. The rear axle stronger. And the brakes are beauties! They're 10 ins. in diameter, with a big 138.62 sq. in. of lining area (now bonded for longer life) to handle steep hills and maximum loads. And there are dual hydraulic circuits for fail-free safety.

## New road-sure ride and handling

The new Holden utes and vans all have the same wider track, longer wheelbase and lower centre of gravity as the new generation Holden sedans. So you can expect the same dramatic improvements in roadholding, ride and handling. Steering is now lighter, for those who like it that way, or there's an alternative faster ratio if you wish. You can also specify a limited slip differential for better handling on good roads, vastly improved traction in the rough.

## New elegance inside and out

Kingswood's glamorous exterior styling is matched by new interior luxury that tells you right away you're going first class. Seats are softer, with higher backs and more padding for comfort. New two-tone Sadlon upholstery, colour-keyed to the 'Magic-Mirror' finish outside, is easy to care for and easy on the eye. Improved ventilation, now with central control, provides more air more easily. The ashtray is now in the centre, and so's the handbrake. There's 75% more room in the glove box. A cigarette lighter is standard equipment. So is the complete Holden safety package including GM-developed energy-absorbing steering.

## Extra luxury? Just say the word!

You can equip your Kingswood with as much luxury as you like, right up to air-conditioning by Frigidaire that lets you control your own weather regardless of heat and dust outside. Powerglide automatic transmission, bucket seats, tinted or laminated glass, heater/demister, push-button radio, disc brakes... there's almost no limit to the niceties you can add. See the full list on Page 7.

*You'd be happy to go anywhere, with anyone, in this kind of comfort.*





# HOLDEN BELMONT UTILITY & PANEL VAN

More size where you want it!  
More strength where it counts!  
And a bigger 13½ cwt payload!

Doors now open right out to 62". And both have key locks.



## The lowest price of all!

The new Belmont Utility and Panel Van are built to take a beating without bruising your budget. They've got the same extra size, strength and payload as the new Kingswood Utility — and your savings are even greater. Not just when you buy, but every mile you drive. (The same reason why Holden utes and vans *always* outsell other makes by such a wide margin.)

## Low maintenance! Maximum reliability!

Holden cuts maintenance right to the bone... with lubrications at 6,000 mile intervals, oil changes at 6,000, hydraulic valve lifters to eliminate tappet adjustment, and an alternator to boost the life of your battery. Brakes are self-adjusting — and the linings bonded for longer life. The fuel tank now holds 16½ gallons so you can go non-stop for long distances. And with Holden's legendary reliability, the irritations of normal motoring just don't happen. Repair bills are fewer and smaller. And spare parts cost less, are always available when you *do* need them.

## Sturdier construction! Longer life!

Underneath, Holden is built like a bank vault, with heavier metal where it's needed for strength and durability. 'Double-life' body construction gives you a double floor in the cargo area — an all steel panel topped by a composite hardboard floor with protective steel strips. Wheel arches are in heavier gauge metal, virtually dent-proof.

## New 'Rustgard' process beats corrosion

You can't see it, but years from now you'll be glad it's there. 'Rustgard' is a new process,

now applied to all Holdens, which starts by coating key panel areas with zinc rich primer, *before* they are assembled. Then comes a thorough cleaning, degreasing, phosphating and 3-stage priming to provide a perfect base for the final three coats of 'Magic-Mirror' acrylic lacquer that preserve both car and resale value so well. Chromework, too, is now protected against corrosion by a new 'Dur-Ni' process. And Holden has front fender inner skirts to ward off stones and slush.

## New ride! New room! New comfort!

Belmont has the new, road-sure handling that distinguishes all new Holdens. And this roomy 3-man cabin is just the place to enjoy it. A larger windscreen and lower steering wheel improve driving vision and make the going even more pleasant. A wide bench seat (or buckets if you wish) is comfortably padded and covered in sturdy Sadlon upholstery. All controls, including the centrally-placed handbrake and fresh-air ventilation, fall readily to hand. Flat floors, easy to sweep out, are covered with perfect-fitting rubber mats. There are locks on *both* doors.

## Performance? It's up to you!

Standard engine is Holden's 114 hp '161'. Or you can specify 126 hp, 145 hp or the new 210 hp 5-litre V8. The choice is also wide when it comes to gear changing. Three-on-the-column, with synchro, on 2nd and 3rd, is standard. Then there's a heavy-duty 3-speed all synchro. column shift. Or Powerglide automatic transmission. Also worth thinking about is Holden's limited slip differential. It transmits power to the wheel with grip, not the one that's spinning.



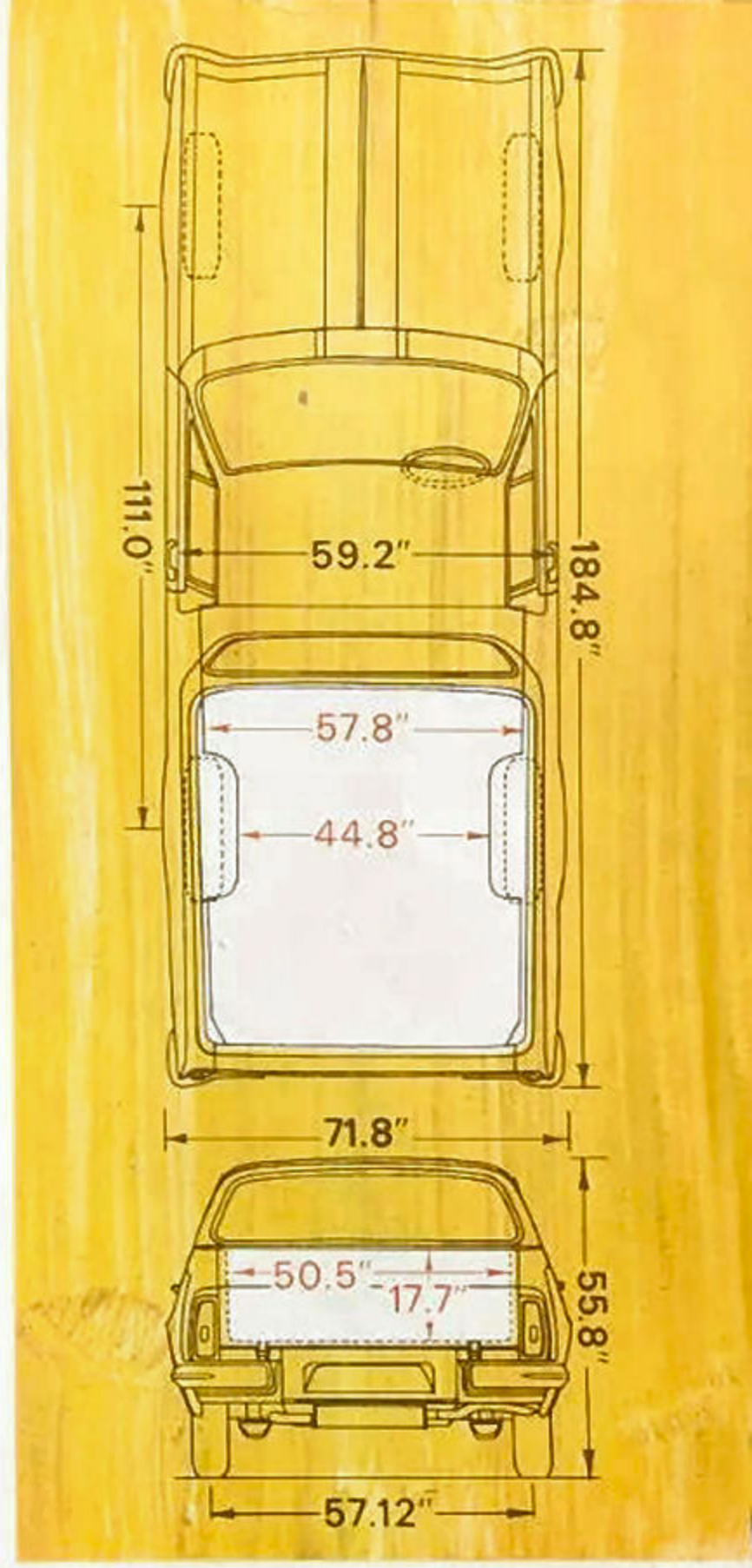
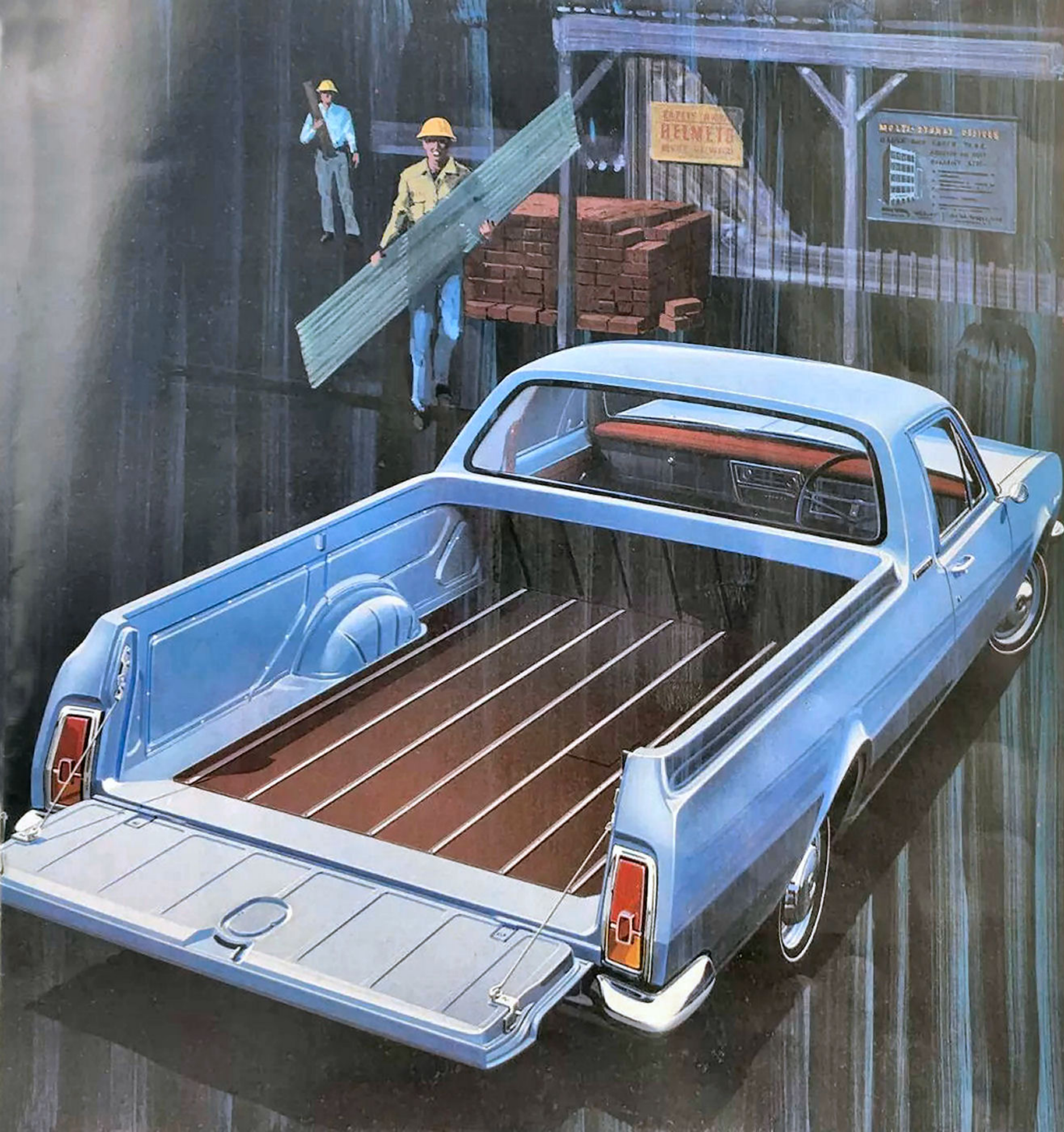

Wheel arches now in heavier-gauge metal.

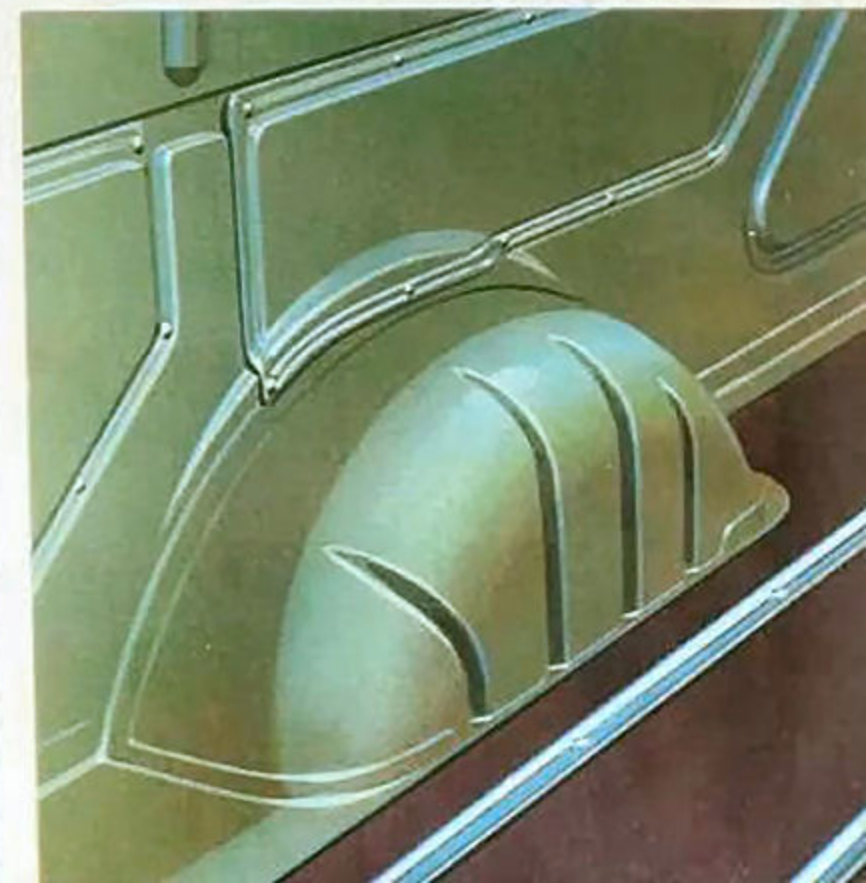



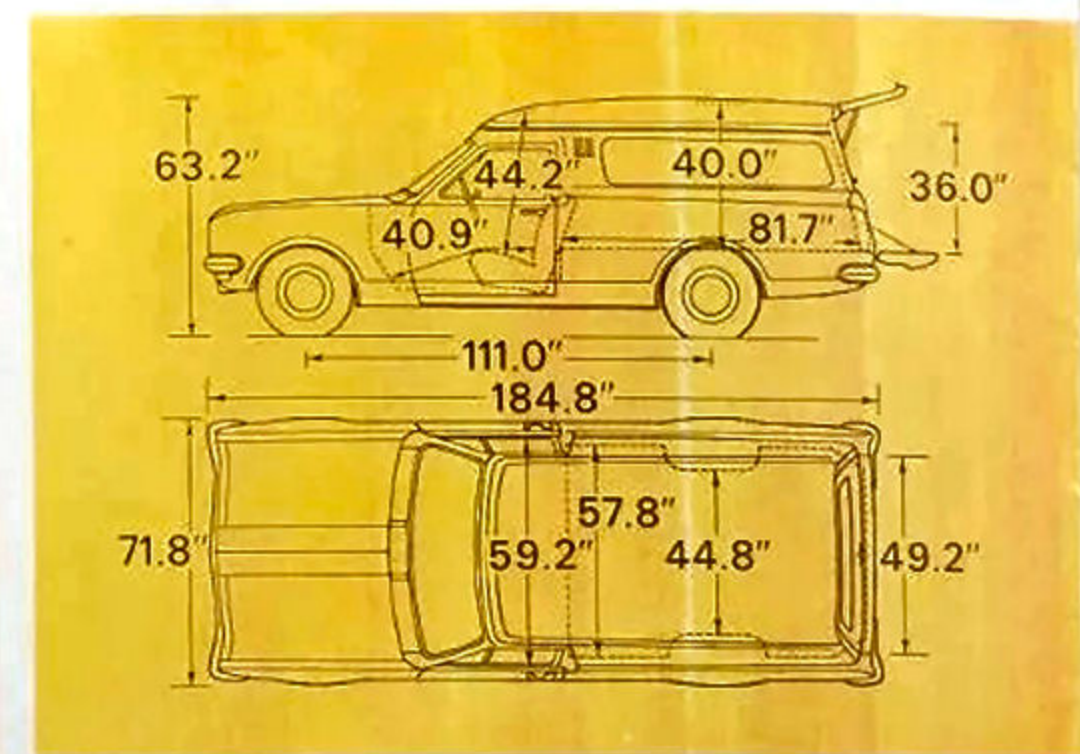

## BELMONT PANEL VAN Carries 13½ cwt in great style. Tougher in every way—except on the driver.

The new Belmont Panel Van, like the two Holden Utilities, is now bigger and stronger to take an increased 13½ cwt. payload. Inside cargo space has also been boosted to more than 90 cubic feet. So you can quickly see that Holden's famous profit-earning capacity, already a prime reason for its close on 4 to 1 sales leadership over its nearest competitor, is going to be more in evidence than ever.

**Faster, more efficient deliveries.** Dry cleaners, florists, TV repairmen, plumbers . . . van users in **every** business will find that the new Belmont gives them more of what they want at the price they want to pay. Effortless 6-cylinder or V8 performance wastes no time getting you where you're going and back again — so that even single deliveries are a profitable venture. There's a tight turning circle for easy manoeuvrability in traffic. And a new 16½ gallon petrol tank (5 more than before) to take you non-stop for many more miles.

**Wide rear doors for easy loading.** Loading up couldn't be easier. Tailgate width is 49.2 ins., the cargo height 40 ins., from floor to roof. Like all the new Holden commercials, the Belmont's floor area is larger and wider than before. Lower the tailgate and you have a flat deck nearly 8 ft. 5 ins. long. Or you can drop the tailgate all the way down when backing up to a loading bay.

**New good looks are good for business.** Belmont's handsome good looks — with smart new styling sweeping back from front to rear — can't help being an asset to your business. And the good looks are there to stay with Holden's 'Magic-Mirror' acrylic finish, and, underneath it all, the new 'Rustgard' process to beat corrosion and keep resale value high.

**Driving comfort? It's a pleasure!** When you spend long hours with your vehicle, you're entitled to do it in comfort. And the new

Belmont sees to it that you do. Steering is now lighter — and the wheel itself lower for more relaxed driving. Getting in and out — which used to be a tiresome chore — is now much easier with doors that open right out to 62°. And inside, there's a wide 3-man seat (or buckets if you wish), covered in easy-to-clean Sadlon, with thick foam padding on a foundation of steel springs. You could cheerfully drive all day in these restful surroundings. And as you can see from the list at right, there's virtually no limit to the extra luxuries you can enjoy.

**Greater strength for longer life.** The new Belmont Panel Van has the same 'Double-Life' construction as the two Holden Utilities — including the double floor and those heavier gauge wheel arches that will take solid knocks without denting. You also get all the benefits of Holden's new road-sure ride and handling. The complete Holden safety package. Not to mention all those proven money savers we've already listed on Page 4.



# 5 LITRES BIG! 210 HORSES STRONG! THAT'S HOLDEN'S MIGHTY NEW V8 ENGINE

It's the biggest, most powerful engine ever to propel Australia's Own Car. The figures speak for themselves! 5 litres displacement, 210 hp at 4,600 rpm, max. torque 300 lbs./ft. at 2,400 rpm. But figures alone don't even begin to tell the story. More important is the spirited response you get to cope with any emergency, the flexibility in traffic, and the effortless way this great engine will do anything you ask of it. To say nothing of its remarkable economy. You can order V8 power with any of the new Holdens, and with it goes a limited slip differential, a heavy duty battery and Powerglide automatic transmission to complete the package.

## or choose from three great 'sixes'

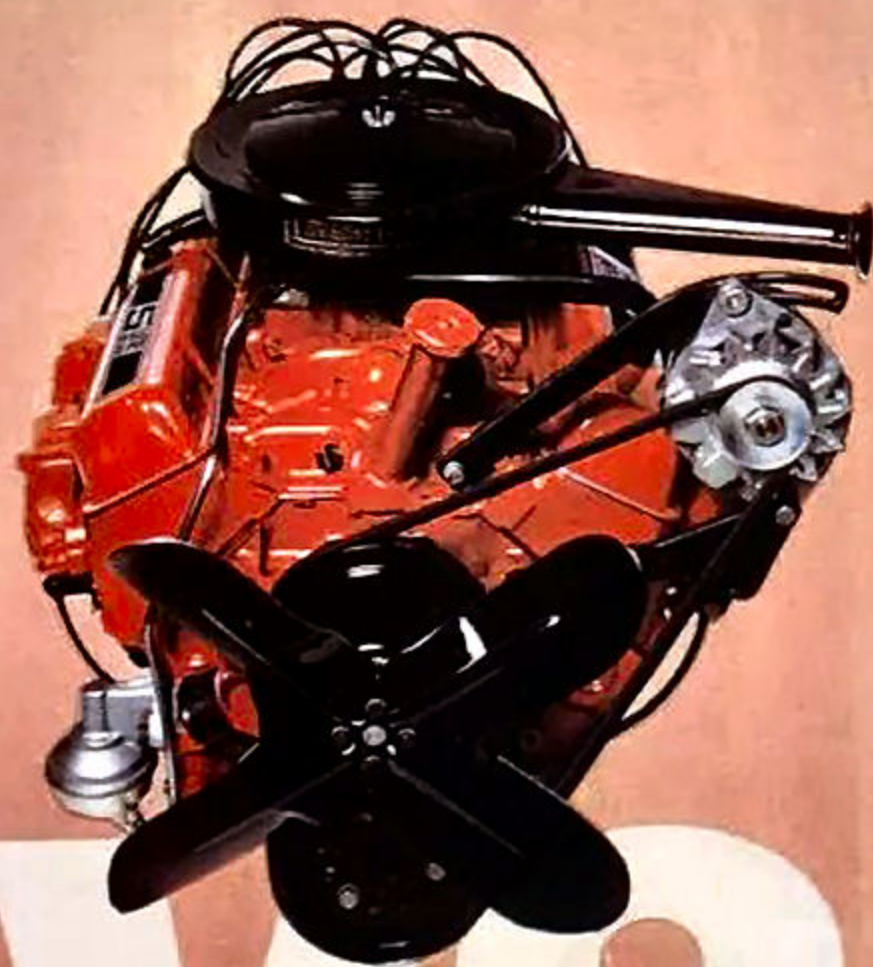

# V8

### 114 HP '161'

Economy at its savingest so we've made this the standard engine on the new Utilities and Van. But it's still no slouch when it comes to turning on the steam.



### 126 HP '186'

A higher performance 'six' that provides extra reserves of power for quick overtaking, extra torque when you need it. Can be ordered with all models.

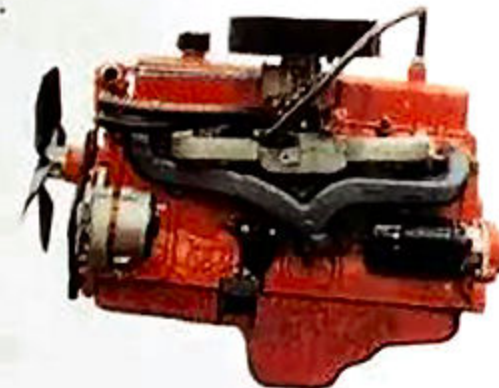

### 145 HP '186S'

6 cylinder performance at its fiercest. There's a single 2-barrel carburettor for sweeter running and simplified tuning. Automatic choke gives easy starting in all weathers.

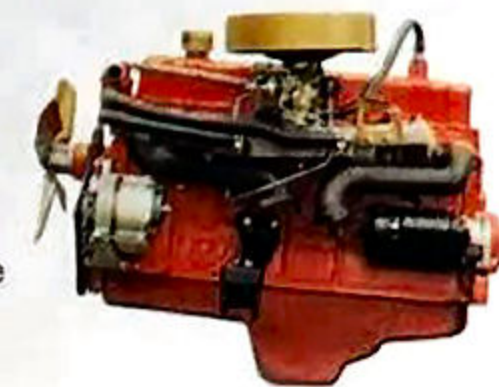

## PERSONALIZING YOUR NEW HOLDEN UTILITY OR VAN

With your new Holden 13½ cwt. utility or van comes the biggest range of factory-fitted custom features ever offered. In fact, we can only mention the more important of them here. Ask your Holden Dealer to show you a complete list, so you can 'tailor' your ute or van to your personal requirements.

### ENGINES

114 hp '161' is standard equipment on all models. For higher performance, the 126 hp '186', 145 hp '186S' or 5-litre, 210 hp V8 are available.

**Note:** The '161' can be ordered in a low-compression version giving 108 hp if desired.

### TRANSMISSIONS

Standard gearshift with all 6-cylinder engines is three-on-the-column with synchromesh on 2nd and 3rd. Or you can choose a heavy duty all-synchro. three-on-the-column, or Powerglide automatic transmission (*mandatory with V8*).

### HANDLING AND PERFORMANCE

**Front Disc Brakes** for fast stopping without fade under hard driving conditions. **Power Brakes** make stopping easier, surer under all conditions. **Power Steering** (*fast ratio mandatory*) for easy parking and command of the road. **Fast Ratio Steering** for the ultimate in precise, direct action. **'Superlift' Rear Shock Absorbers** can be adjusted to suit heavy load or road conditions by 'pumping them up' as you would a tyre. **Limited Slip Differential**. As long as one wheel grips, you go.

### INTERIOR EQUIPMENT

**Contoured bucket seats** for day-long comfort. **Air-conditioning** by Frigidaire lets you control your own weather at a touch (now with all engines). **Radios**, 6 or 11 transistor, push-button or manual. **Deluxe heater/demister** (now fitted in engine compartment) gives vastly improved performance. **High performance instrument cluster** with ammeter, oil pressure and water temperature gauges tell you in greater detail what's going on under the bonnet.

### EXTERIOR EQUIPMENT

- Clip-on Tonneau Cover ● Lash-on Tonneau Cover ● Sports wheel discs ● Wheel trim rings ● Tinted or laminated windshield
- 7.35 x 14 tyres, 6-ply tubeless ● Whitewall tyres ● Redwall tyres ● Radial ply tyres ● Nylon cord tyres

### HEAVY DUTY ITEMS

A heavy duty radiator, battery and air cleaner (except with 186S and V8 engines), and heavy-duty seats are available on all models, if required.



# HOLDEN'S FAMOUS SAFETY PACKAGE IS ALL HERE! (We haven't forgotten a single item)

Your driving safety is Holden's driving concern. So we've included every one of Holden's long list of safety items as standard equipment. Which means they cost you not a single cent extra.

## ENERGY-ABSORBING STEERING

A GM development. Under impact, the steering column compresses up to 8 inches, reducing danger of injury.

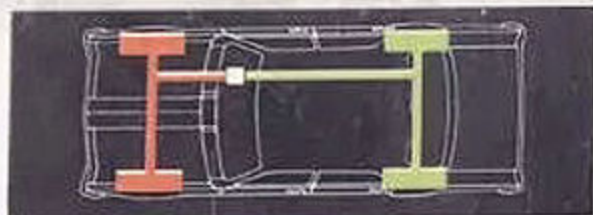
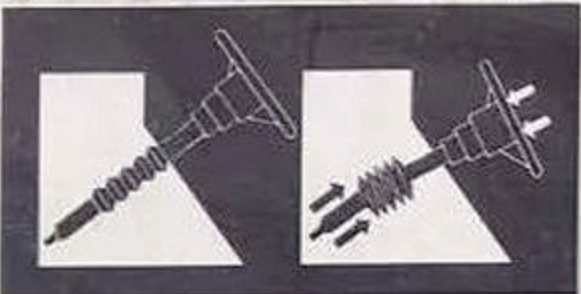

## DUAL CIRCUIT BRAKING

There are completely separate hydraulic systems for front and rear brakes. If one system loses pressure, you still have full braking power on two wheels.

Double-sided safety rims on all wheels. Fusible link wiring virtually ends fear of electrical fires. Two-speed electric windshield wipers with non-glare blades and arms. Glare-reducing instruments and controls. Back-up

Lamps operate automatically when you engage reverse. Outside rearview mirror on driving side door. Self-adjusting brakes always at peak efficiency. Positive crankcase ventilation reduces atmospheric pollution. Lap/sash seat belts in matching colours, and with handy pillar clips. Low profile instruments and controls. Safety padding in all the right places. Safety-type doors with locking snibs, anti-burst locks and extra strong hinges. Shatterproof Inside Rearview Mirror (utilities only) so designed that the entire fitting will 'knock out' under impact. 'Modified Zone' Windshield retains a clear area of vision, in front of driver, if the rest of the windscreen becomes opaque through impact.



## Proved right for Australia

Long before any Holden reaches the production line, prototypes are tested and tortured by GMH engineers for the equivalent of hundreds of thousands of miles at the GMH Proving Ground at Lang Lang, Victoria. You're buying a thoroughly proven vehicle in Holden.

# SPECIFICATIONS

## Holden Utilities and Panel Van

**'161' ENGINE:** 6-cylinders. Bore & Stroke 3.375 x 3.00 ins. Max. bhp 114 @ 4,400 rpm. Max. torque 157 lbs. ft. @ 2,000 rpm. Compression ratio 9.2:1 (Optional comp. ratio 8.2:1 giving 108 bhp @ 4,400 rpm). SAE (or RAC) rating 27.34 hp.

**'186' ENGINE:** 6-cylinders. Bore & Stroke 3.625 x 3.00 ins. Max. bhp 126 @ 4,200 rpm. Max. torque 181 lbs. ft. @ 1,600 rpm. Compression ratio 9.2:1. SAE (or RAC) rating 31.54 hp.

**'186S' ENGINE:** 6-cylinders. Bore & Stroke 3.625 x 3.00 ins. Max. bhp 145 @ 4,600 rpm. Max. torque 184 lbs. ft. @ 2,200 rpm. Compression ratio 9.2:1. SAE (or RAC) rating 31.54 hp.

**V8 ENGINE:** Bore & Stroke 3.875 x 3.25 ins. Capacity 307 cu. ins. Max. bhp 210 @ 4,600 rpm. Max. torque 300 lbs. ft. @ 2,400 rpm. Compression ratio 8.75:1. SAE (or RAC) rating 48.05 hp.

**6 CYLINDER ENGINE FEATURES:** OHV in-line engine of oversquare design. Modified wedge design combustion chambers. Seven bearing crankshaft. Hydraulic valve lifters. Special water-heated inlet manifold. '186S' has tri-metal main and crank pin bearings, twin exhaust manifolds.

**V8 ENGINE FEATURES:** OHV design. Full pressure lubrication system. Hydraulic valve lifters, camshaft contoured for lively performance plus economy.

**FUEL SYSTEM:** Bendix Stromberg one barrel downdraft carburettor (186S has a 2-barrel Bendix Stromberg and the V8 a 2-barrel Rochester, each with automatic choke). AC fluid treated replaceable paper element air cleaner and silencer. Optional heavy-duty air cleaner on '161' and '186' engines. Fuel tank capacity 16.5 imp. gals.

**LUBRICATION:** Full pressure system, AC full flow disposable type oil filter with oil non-return check valve.

**CRANKCASE VENTILATION:** Positive ventilation to inlet manifold on '161' and '186', to carburettor on '186S' and V8.

**COOLING:** Pressurised, with full length water jackets around each cylinder. Thermostat control. Centrifugal water pump.

**ELECTRICAL:** 12 volt battery, 44 amp. hour capacity on 'sixes', 53 amp. hour on V8. Both @ 20 hour rating. 35 amps. alternator. Optional heavy-duty batteries — 53 amp. hours and 61 amp. hours.

**MANUAL TRANSMISSION:** 3-speed column shift with synchromesh on 2nd and 3rd. Heavy-duty all synchromesh 3-speed column shift is an optional Custom Feature.

**AUTOMATIC TRANSMISSION:** 'Powerglide' with column control. Hydraulic torque convertor coupled with planetary gear system. Mandatory with V8 engine.

**REAR AXLE RATIOS:** 3.55:1 with manual transmission models. 3.36:1 with 6-cylinder 'Powerglide' automatic transmission. 2.78:1 (Limited Slip) with V8. Optional limited slip differential with other models.

**BRAKES:** Four wheel hydraulic, duo servo, with separate hydraulic circuits for front and rear. Bonded linings, total effective area 138.62 sq. ins. Automatic adjustment. Optional power brakes. Optional power-assisted front discs.

**SUSPENSION:** Front: Independent, short and long arm, coil springs. Stabiliser bar. Rear: Semi-elliptical 6-leaf springs. Direct acting shock absorbers front and rear. 'Superlift' rear shock absorbers optional.

**STEERING:** Energy-absorbing steering column and shaft. Recirculating ball. Life lubricated. 36.5 ft. turning circle. Gear ratio 20.0:1. Optional 16.7:1 fast ratio (not with V8 unless power steering fitted). Optional power steering (fast ratio mandatory).

**WHEELS AND TYRES:** Short spoke disc wheels, 14 x 5.00J. Double sided safety rims. Tubeless 6.95 x 14 x 6-ply low profile tyres. Optional tyres include 7.35 x 14 6-ply tubeless, whitewalls, redwalls, radial ply and nylon cord.

**LIGHTING:** Sealed beam headlamps. Foot dimmer switch. Front signal lights combine with parking lamps. Rear lamps combine tail, stop, turn signal, back-up lights and reflectors. Rear licence plate lamps. Indirect instrument panel lighting. Illuminated selector indicator dial (automatic).

**BODY STRUCTURE:** All steel 'Aerobill' construction. Wheelbase 111.0". Track front and rear 57.12". Overall length, utility and panel van, 184.8". Overall width 71.8".

**INSTRUMENT PANEL:** Safety padded. Speedometer, petrol gauge, warning lamps for water temperature, oil pressure, generator charging, turning signal and high beam. Five position ignition/starter switch. Main light switch, wiper/washers switch. Mileage indicator, central ashtray, lockable glove box, choke control. Central fresh air control knob. Engine hood release.

**G.V.W.** Utilities 4,312 lbs. Panel Van 4,368 lbs. Approximate kerb weights: Belmont Utility 2,754 lbs. Kingswood Utility 2,762 lbs. Belmont Panel Van 2,855 lbs. Add 216 lbs. for V8 engine including Powerglide.

**THE GMH WARRANTY:** Protects your Holden for 12 months or 12,000 miles. Additionally, the GMH Guardian Maintenance Plan provides for free inspection and adjustment by your Holden Dealer after the first 2,000 miles.

**Confidential Time Payment:** General Motors Acceptance Corporation provides confidential time payment facilities through Holden Dealers everywhere.

**Please Note:** All specifications, while correct at the time of printing, are subject to change without notice.



## 'Double-Life' Body Construction

Holden Utilities and Panel Vans are the toughest in the business, and one reason is their exclusive 'Double-Life' construction. The load compartment has a double floor, all steel underneath, and with a replaceable top section of composite hardboard, protected by steel strips. Side panels, too, have double walls for extra strength.