

# 2007 SIERRA



2007  
SIERRA

**GMC**



## SIERRA. IT'S THE ONE.

At GMC, we're as serious about your work as you are. That's why our trucks are engineered and built professional grade. Take Sierra, for example. The Sierra family offers it all. Willing power. Massive torque. Envious fuel economy. Tremendous towing and hauling capabilities. Spacious, comfortable interiors. And quality, reliability and durability that set the benchmark for the industry. Sierra. There's no substitute for professional grade.



For more information about Sierra,  
visit our website at [sierra.gmcanada.com](http://sierra.gmcanada.com)

**GMC**

PROFESSIONAL GRADE

## SIERRA 1500

### THE HALF-TON OF CHOICE.

When you need an over-achieving half-ton truck, look no further than Sierra. With a broad range of models to choose from, there's a half-ton Sierra that's right for whatever you've got in mind. The selection includes rugged 1500 and hard-working 1500HD models, the luxurious Sierra Denali and the powerful yet economical Sierra Hybrid. There's even an available VortecMAX Performance Package with a class-leading 4717 kg (10,400 lb.) towing capacity. There's an amazing variety of vehicle configurations and trim levels to choose from, too, so it's easy to find the truck that's the perfect fit for your needs. And every Sierra 1500 delivers the serious capability you expect in a genuine GMC truck, so you can count on professional grade performance no matter which model you select.



SIERRA 1500 SLT 4X4 CREW CAB, shown in Fire Red.

## SIERRA HYBRID

### HAVE YOUR CAKE. AND EAT IT, TOO.

Sierra Hybrid is one of Canada's most fuel-efficient full-size pickups. It's also a seriously hard-working, top-performing truck, thanks to a Vortec 5.3L V8 with 295 horsepower and 335 pounds-feet of torque. What makes this seemingly impossible combination possible? The answer is GM's unique hybrid technology. Instead of a conventional starter motor and alternator, Sierra Hybrid features a compact 14-kW electric starter/generator integrated neatly between the engine and transmission. When Sierra Hybrid is braking at speeds below 21 km/h (13 mph) or when the vehicle is not moving, the auto start/stop feature shuts down the engine to save fuel – realizing up to 12% increase in fuel economy.\* When it's time to go the starter/generator instantly and automatically restarts the V8. It also smooths out any driveline surges and recharges the batteries on-the-go with the starter/generator when the vehicle is running and by capturing energy during braking. It even sends up to 20 amps of AC current to Sierra Hybrid's four 120-volt outlets – a handy thing when you need to run power tools at a remote job site.

\*Based on a comparison of city driving for the conventional Sierra model to the Hybrid model.



## SIERRA 2500HD & 3500



### HEAVY-DUTY HAULERS.

When your projects are more than a light-duty truck can handle, look no further than Sierra 2500HD and 3500. The standard engine in both trucks is a 300 horsepower Vortec 6.0L V8. The big block Vortec 8.1L V8 and the asphalt-rending Duramax Diesel 6.6L V8, which generates a class-leading 650 lb.-ft. of torque\*, are also available. Payload capacity ranges up to 2500 kg (5511 lb.). And these trucks' towing capabilities are even more impressive. Properly equipped, Sierra 3500 can tow a massive 7575 kg (16,700 lb.) with a fifth-wheel hitch.

\*Based on 2006 Model Year data for the GM Large Pickup segment and the latest published competitive information available at time of printing.



SIERRA 2500HD SL 4X4 REGULAR CAB, shown in Silver Birch Metallic.



SIERRA 2500HD SLT 4X4 CREW CAB, shown in Summit White.

## INTERIOR

### YES, IT REALLY IS A PICKUP.

Inside Sierra, it's often hard to believe you're in a pickup at all. The ride is impressively smooth and controlled and the roominess, comfort level and choice of amenities rival many premium sedans. Sierra includes a long list of standard features - such as air conditioning\*, tinted glass and a multi-function Driver Information Centre - which add to your comfort and convenience. Then there are the controls, all so well designed and positioned that using them is almost intuitive. Even the climate control system has been designed to make driving safer and more convenient. It's easy to adjust, even when you're wearing gloves.

\*Except Regular Cab Value Leader model.



SIERRA INSTRUMENT PANEL, shown with available equipment.



SIERRA CREW CAB SLT INTERIOR, shown in Dark Pewter.

# ENGINES

## FEEL THE POWER.

Sierra offers a quality engine for every application. Choices include the very economical Vortec 4.3L V6, a selection of seven gasoline-powered Vortec V8s plus the awesome Duramax Diesel 6.6L V8 and its ground-pounding 650 pounds-feet of torque. Sierra also offers a Vortec 5.3L V8 that is specially adapted to run on E85 (up to 85 percent ethanol) fuel.

There's even a Sierra model with a hybrid powertrain that uses cutting-edge gas/electric technology to help improve fuel efficiency.



The big block Vortec 8.1L V8 produces 330 horsepower and 450 lb.-ft. of torque - the most torque of any gasoline V8 pickup engine.\*

\*Based on 2006 Model Year data for the GM Large Pickup segment and the latest published competitive information available at time of printing.

With its high-pressure common rail direct injection, the Duramax Diesel 6.6L V8 is one of the most advanced diesels available in any pickup.

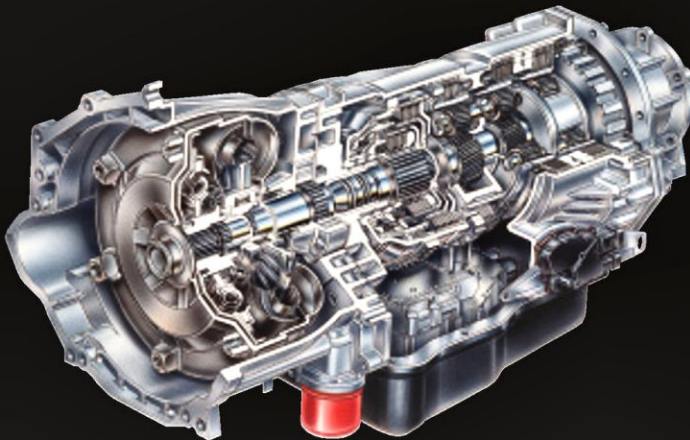

To help you take maximum advantage of the power and torque produced by the Duramax Diesel 6.6L V8 and Vortec 8.1L V8 engines, they're paired with a heavy-duty 6-speed Allison automatic transmission.



# TOWING

**ANY TRAILER. ANYWHERE.  
ANY TIME.**

If your needs include trailer towing, Sierra has all the muscle you require. Every Sierra model comes with impressive towing capability, and Sierra offers a number of standard and available features to make the job easier. A Tow/Haul mode, for instance, is integrated into every automatic transmission. On four-speed automatics, it modifies the transmission's shift pattern for greater performance when you need it. Sierra also offers an available factory-installed heavy-duty Trailering Special Equipment Package that includes a weight-distributing hitch receiver, a trailer brake control wiring harness and more.



**SIERRA 3500 SLT 4X4 CREW CAB**  
with dual rear wheels, shown in Silver Birch Metallic with available equipment.

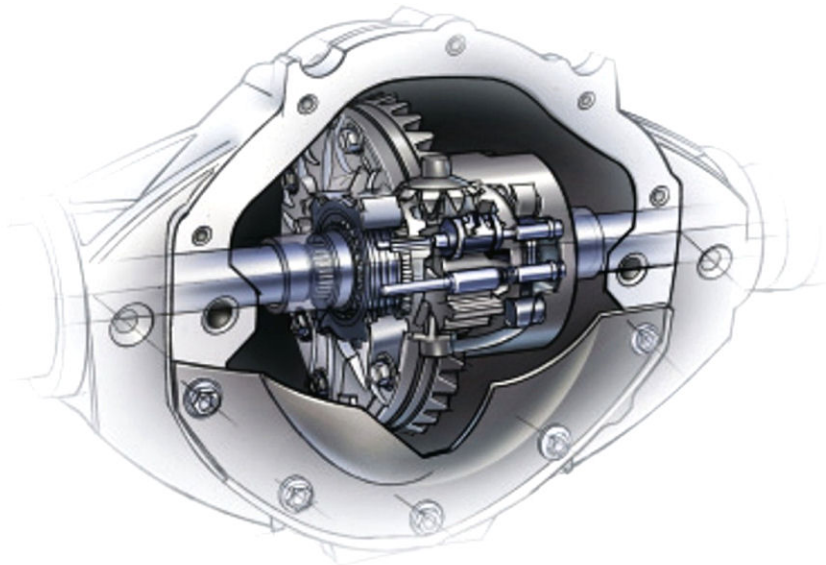

Standard on all Sierra 4x4 SLE and SLT models and available on other models, the locking rear differential helps get your vehicle moving when one rear wheel loses traction by directing power to the wheel with better grip.

# TECHNOLOGY

## IN THE LEAD TO STAY

At GMC, our obsession with building professional grade trucks means we're constantly innovating and raising the bar. For proof, consider some of the advanced technology pioneered by Sierra. Sierra was the first pickup with precise, robust, lightweight hydroformed frame components. The first with the security and convenience of OnStar. The first with advanced Electronic Throttle Control. The first with a Tow/Haul mode that electronically alters transmission performance for heavy hauling. And the first to offer a rugged gas-electric hybrid powertrain that delivers an increase of up to 12% in fuel economy. Bottom line: when it comes to engineering, Sierra leads the way.

### 1. CRUSH CAPS

On 1500 models, easily replaced crush caps at the front end of the frame are designed to absorb energy in a collision, in order to cushion the passenger compartment.

### 2. PRECISE SUSPENSION MOUNTING

Sierra's hydroformed front frame section allows the precision mounting of suspension components, resulting in better wheel alignment and improved ride and handling characteristics.

### 3. HYDROFORMED FRONT FRAME

Formed through the application of very high levels of hydraulic pressure, the boxed steel front frame section is stronger, lighter and more dimensionally precise than conventional welded steel frames.

### 4. 6-BOLT WHEELS

For added strength, Sierra 1500 models ride on six-bolt wheels. Sierra 1500HD, 2500HD and 3500 models go even further, with standard eight-bolt wheels.

### 7. HIGH-TEMPERATURE WAX

To eliminate any need for heat shields as used on some competitive pickup trucks, the corrosion-fighting wax applied to the Sierra frame has a very high melting point of 146°C (295°F).



### 5. HIGH-STRENGTH ROLLED STEEL MID-FRAME

The midframe begins as a solid, straight piece of 40,000 PSI yield-strength steel. The steel is then roll-formed and draw-bent into a lipped "C" shape without stamping, increasing its strength without adding mass.

### 6. STAINLESS STEEL EXHAUST

To provide long life and reduce maintenance requirements, Sierra's exhaust system is made of stainless steel. Sections behind the catalytic converter are aluminized for an improved appearance.

### 8. STRAIGHT-RAIL REAR FRAME

The rear frame is a strong, straight-rail design that easily accepts a variety of trailer hitches. It also contributes to the high trailering capacities of all Sierra models.

### 9. TUBULAR CROSS MEMBERS

For added rigidity, the Sierra frame is reinforced by a series of tubular cross members. Unlike the stampings used on some competitive vehicles, these cross members add strength with less weight.





# SIERRA ACCESSORIES

## IMPROVE ON PERFECTION.

How do you make a great pickup truck even greater? By upgrading its appearance and function with carefully selected GM Accessories. GM Accessories are the only accessories that are integrated into the process of designing your vehicle, ensuring excellent fit, finish and functionality. And only GM Accessories are backed by GM's 3-year/60,000 km New Vehicle Limited Warranty.\* They can also be included in your new-vehicle lease or finance agreement through GMAC. Ask your dealer for a complete list of the GM Accessories available for Sierra. Or visit [gmcanada.com](http://gmcanada.com)

\*Whichever comes first, when permanently installed at the time you purchase or lease your new vehicle.



### AVAILABLE SIERRA ACCESSORIES INCLUDE:

- 20-inch aluminum wheels
- Front end cover
- Moulded bed liner
- Tubular bed rail protectors
- Performance exhaust system with chrome exhaust tips
- Moulded running boards
- Ventvisors
- Chrome mirror covers
- Chrome door handles
- Chrome fuel door
- Premium all-weather floor mats
- Hard/soft tonneau cover.



Canada 

## Accessories

# SIERRA ENGINE & TRANSMISSION AVAILABILITY

Series	Cab Type	Model Number	Vortec 4.3L V6 <sup>1</sup> 195 hp @ 4600 rpm 260 lb.-ft. torque @ 2800 rpm	Vortec 4.8L V8 <sup>2</sup> 285 hp @ 5200 rpm 295 lb.-ft. torque @ 4000 rpm	Vortec 5.3L V8 <sup>2</sup> 295 hp @ 5200 rpm 335 lb.-ft. torque @ 4000 rpm	Vortec 6.0L V8 <sup>3</sup> 300 hp @ 4400 rpm 360 lb.-ft. torque @ 4000 rpm	VortecMAX 6.0L V8 <sup>3</sup> 345 hp @ 5200 rpm 380 lb.-ft. torque @ 4000 rpm	Vortec 8.1L V8 <sup>4</sup> 330 hp @ 4200 rpm 450 lb.-ft. torque @ 3200 rpm	Duramax Diesel <sup>4</sup> 6.6L V8 360 hp @ 3200 rpm 650 lb.-ft. torque @ 1600 rpm
<b>1500</b>	Regular Cab	C15703	S	O	O <sup>5</sup>	-	-	-	-
		C15903	S	O	O <sup>5</sup>	-	-	-	-
		K15703	S	O	O <sup>5</sup>	-	-	-	-
		K15903	S	O	O <sup>5</sup>	-	-	-	-
	Extended Cab	C15553	-	-	S	-	-	-	-
		C15753	S	O	O <sup>5</sup>	-	O <sup>7</sup>	-	-
		C15753 Hybrid	-	-	S	-	-	-	-
		C15953	-	S	O <sup>5</sup>	-	-	-	-
		K15553	-	-	S	-	-	-	-
		K15753	-	S	O <sup>5,6</sup>	-	O <sup>7</sup>	-	-
		K15753 Hybrid	-	-	S	-	-	-	-
		K15953	-	S	O <sup>5</sup>	-	-	-	-
	Crew Cab	C15543	-	-	S	-	O <sup>7</sup>	-	-
		C15543/Classic	-	S	-	-	-	-	-
		K15543	-	-	S	-	O <sup>7</sup>	-	-
		K15543/Classic	-	S	-	-	-	-	-
K15543/Denali		-	-	-	-	S	-	-	
<b>1500HD</b>	Crew Cab	C15743	-	-	-	S	-	-	-
		K15743	-	-	-	S	-	-	-
<b>2500HD</b>	Regular Cab	C25903	-	-	-	S	-	O	O
		K25903	-	-	-	S	-	O	O
	Extended Cab	C25753	-	-	-	S	-	O	O
		C25953	-	-	-	S	-	O	O
		K25753	-	-	-	S	-	O	O
		K25953	-	-	-	S	-	O	O
	Crew Cab	C25743	-	-	-	S	-	O	O
		C25943	-	-	-	S	-	O	O
		K25743	-	-	-	S	-	O	O
		K25943	-	-	-	S	-	O	O
<b>3500</b>	Regular Cab	K35903	-	-	-	S	-	O	O
	Extended Cab	C35953	-	-	-	S	-	O	O
		K35953	-	-	-	S	-	O	O
	Crew Cab	C35943	-	-	-	S	-	O	O
		K35943	-	-	-	S	-	O	O

S = Standard O = Optional

<sup>1</sup> A 5-speed manual transmission is standard on Regular Cabs. A 4-speed automatic transmission is optional.

<sup>2</sup> A 4-speed automatic transmission is standard on all models.

<sup>3</sup> In 2500HD and 3500 models equipped with a Vortec 6.0L V8, a heavy-duty 5-speed manual transmission is standard. A heavy-duty 4-speed automatic transmission is optional.

<sup>4</sup> Requires Allison 6-speed automatic transmission.

<sup>5</sup> Available Vortec 5.3L V8 engine, capable of running on E85.

<sup>6</sup> Available aluminum engine block High-Output Vortec 5.3L V8 with 310 hp.

<sup>7</sup> Available with VortecMAX Performance Package or Sierra Performance Edition.

Note: Some up-level series include a larger engine than indicated on this chart. Please ask your Sales Consultant for details.

# SIERRA MODEL SELECTOR

Series	Cab Type	Model Number	Wheelbase mm (in.)	Drivetrain	Gross Vehicle Weight Rating Max. – kg (lb.)	Maximum Payload* kg (lb.)	Pickup Box Length (ft. in.)	Max. Gross Trailer Weight** – kg (lb.)	Seating Std./Opt.	
1500	Regular Cab	C15703	3023 (119.0)	2WD	2767 (6100)	857 (1889)	6' 6"	3810 (8400)	3/2	
		C15903	3378 (133.0)	2WD	2903 (6400)	931 (2052)	8'	3720 (8200)	3/2	
		K15703	3023 (119.0)	4x4	2903 (6400)	858 (1892)	6' 6"	4128 (9100)	3/2	
		K15903	3378 (133.0)	4x4	2903 (6400)	801 (1766)	8'	4037 (8900)	3/2	
	Extended Cab	C15553	3404 (134.0)	2WD	2812 (6200)	653 (1440)	5' 8"	3629 (8000)	6/5	
		C15753	3645 (143.5)	2WD	2848 (6500)	714 (1575)	6' 6"	4717 (10,400)†	6/5	
		C15953	4001 (157.5)	2WD	3039 (6700)	681 (1507)	8'	3538 (7800)	6/5	
		K15553	3404 (134.0)	4x4	2903 (6400)	612 (1350)	5' 8"	3946 (8700)	6/5	
		K15753	3645 (143.5)	4x4	3039 (6700)	627 (1382)	6' 6"	4536 (10,000)†	6/5	
		K15953	4001 (157.5)	4x4	3130 (6900)	552 (1217)	8'	3856 (8500)	6/5	
	Crew Cab	C15543	3645 (143.5)	2WD	3130 (6900)	868 (1913)	5' 8"	4581 (10,100)†	6/5	
		K15543	3645 (143.5)	4x4	3175 (7000)	778 (1716)	5' 8"	4491 (9900)†	6/5	
K15543/Denali		3645 (143.5)	AWD	3175 (7000)	714 (1575)	5' 8"	3674 (8100)	5		
1500HD	Crew Cab	C15743	3886 (153.0)	2WD	3900 (8600)	1419 (3129)	6' 6"	4672 (10,300)	6/5	
		K15743	3886 (153.0)	4x4	3900 (8600)	1287 (2838)	6' 6"	4491 (9900)	6/5	
2500HD	Regular Cab	C25903	3378 (133.0)	2WD	4173 (9200)	1841 (4058)	8'	7303 (16,100)	3/2	
		K25903	3378 (133.0)	4x4	4173 (9200)	1725 (3802)	8'	7167 (15,800)	3/2	
	Extended Cab	C25753	3645 (143.5)	2WD	4173 (9200)	1725 (3802)	6' 6"	7212 (15,900)	6/5	
		C25953	4001 (157.5)	2WD	4173 (9200)	1651 (3639)	8'	7122 (15,700)	6/5	
		K25753	3645 (143.5)	4x4	4173 (9200)	1606 (3541)	6' 6"	7076 (15,600)	6/5	
		K25953	4001 (157.5)	4x4	4173 (9200)	1520 (3352)	8'	6985 (15,400)	6/5	
	Crew Cab	C25743	3886 (153.0)	2WD	4173 (9200)	1636 (3606)	6' 6"	7076 (15,600)	6/5	
		C25943	4242 (167.0)	2WD	4173 (9200)	1567 (3455)	8'	7031 (15,500)	6/5	
		K25743	3886 (153.0)	4x4	4173 (9200)	1505 (3317)	6' 6"	6940 (15,300)	6/5	
		K25943	4242 (167.0)	4x4	4173 (9200)	1435 (3163)	8'	6623 (14,600)	6/5	
	3500	Regular Cab	K35903 DRW**	3378 (133.0)	4x4	5171 (11,400)	2500 (5511)	8'	7575 (16,700)	3/2
			K35903 SRW**	3378 (133.0)	4x4	4491 (9900)	1911 (4213)	8'	7076 (15,600)	3/2
Extended Cab		C35953 DRW**	4001 (157.5)	2WD	5171 (11,400)	2425 (5347)	8'	7530 (16,600)	6/5	
		C35953 SRW**	4001 (157.5)	2WD	4491 (9900)	1854 (4088)	8'	7031 (15,500)	6/5	
		K35953 DRW**	4001 (157.5)	4x4	5171 (11,400)	2290 (5049)	8'	7394 (16,300)	6/5	
		K35953 SRW**	4001 (157.5)	4x4	4491 (9900)	1680 (3703)	8'	6895 (15,200)	6/5	
Crew Cab		C35943 DRW**	4242 (167.0)	2WD	5171 (11,400)	2345 (5169)	8'	7439 (16,400)	6/5	
		C35943 SRW**	4242 (167.0)	2WD	4491 (9900)	1809 (3989)	8'	6940 (15,300)	6/5	
		K35943 DRW**	4242 (167.0)	4x4	5171 (11,400)	2199 (4848)	8'	7258 (16,000)	6/5	
		K35943 SRW**	4242 (167.0)	4x4	4491 (9900)	1623 (3578)	8'	6804 (15,000)	6/5	

\*Payload includes passengers, equipment and cargo. Higher payloads may require optional equipment. Payloads are approximate and will change with the addition of optional or aftermarket equipment. Consult your dealer or equipment supplier for details.  
 \*\*Trailer ratings are calculated using an automatic transmission and assuming only the driver is in the tow vehicle. Trailer Weight (also called Trailer Towing Capacity) is the weight of a trailer, its load or contents plus any other weight added to the tow vehicle. Ball-hitch ratings are shown for 1500 and 1500HD models. Fifth-wheel ratings are shown for 2500HD and 3500 models; ball-hitch ratings are 5443 kg (12,000 lb.). For details, ask your Sales Consultant for a copy of the Trailering with GMC Trucks brochure. Many trailer towing applications require additional optional equipment.

†When equipped with the VortecMAX Performance Package (see page 17).

\*\*DRW: Dual Rear Wheel. SRW: Single Rear Wheel.

## ONSTAR

OnStar® uses advanced communications technology to enhance your safety, security and convenience. OnStar Advisors can provide a wealth of information and perform a variety of diagnostic services. They can also provide assistance in an emergency. No wonder more than 4 million people have become OnStar subscribers and over 12 million calls are made each month on the built-in voice-activated, hands-free system. OnStar and one year of the Safe & Sound Plan are standard on Sierra SLT and Denali and available on the Sierra SLE models. See your dealer for more information on plans and services.

\*OnStar services require vehicle electrical system (including battery), wireless service, and GPS satellite signals to be available and operating for features to function properly. Not all OnStar features are available on all vehicles. OnStar acts as a link to existing emergency service providers. OnStar Hands-Free Calling requires a Hands-Free enabled vehicle, prepaid minutes and existing OnStar service contract. Subscription Service Agreement required.



## XM SATELLITE RADIO

What's convinced more than six million people to subscribe to XM Satellite Radio? How about the largest playlist on the planet, with musical genres that span everything from decades to dance, rock to rap and country to classical – broadcasting the most commercial-free music in digital quality sound? Or is it the news, talk, comedy and sports channels – including more than 1,000 NHL games – and all available from coast to coast? XM has revolutionized radio as we know it. And now you can enjoy XM Satellite Radio in your next General Motors vehicle – GM is the first automaker to offer factory-installed satellite receivers. Ask your dealer for more information.

\*Includes three free trial months beyond which service fees apply. Available in 10 Canadian provinces and 48 contiguous United States.



# SIERRA 1500 STANDARD & OPTIONAL FEATURES

SAFETY AND SECURITY	SL	SLE	SLT
Air bags – dual-stage, driver and front-passenger, frontal. Includes Passenger Sensing System with automatic air bag suppression (1500 models only)	S	S	S
Air bags – single-stage, driver and front-passenger, frontal (1500HD models only)	–	S	S
Brake/transmission shift interlock (automatic transmission only)	–	S	S
Door locks – power, programmable with lock-out protection	0	S	S
Headlights – with automatic light control	S	S	S
Keyless entry system – remote, programmable with Panic alarm feature	–	S	S
OnStar In-Vehicle Communications and Assistance Service – includes one-year Safe & Sound Plan	–	0	S
Safety restraints – LATCH (Lower Anchors and top Tethers for Children) – Ext. and Crew Cab only	S	S	S
Theft-deterrent system – PASSLock	S	S	S
Traction assist – electronic, 2WD models	0	0	0

## MECHANICAL

Brakes – power, front disc/rear drum with 4-wheel anti-lock braking system (ABS)	S	S	S
Brakes – power, 4-wheel disc with 4-wheel anti-lock braking system (ABS) on 1500HD, Denali and Hybrid models	–	S	S
Engines – refer to page 14 for complete availability	S	S	S
Engine – block heater	S	S	S
Exhaust system – aluminized stainless steel muffler and tailpipe	S	S	S
Locking differential – rear (standard on 4x4 models except SL and Crew Cab Classic)	0	0	0
Spare tire carrier – rear underbody, winch-mounted with lock	S	S	S
Steering – power, rack-and-pinion on 1500 series 2WD models	S	S	S
Steering – power, recirculating ball on all other models	S	S	S
Suspensions – refer to page 17 for complete availability	S	S	S
Trailer Special Equipment Package – includes weight-distributing platform trailer hitch receiver, 8-lead wiring harness with a 7-pin sealed connector (includes trailer brake control wiring harness), heavy-duty transmission oil cooler and high capacity air cleaner (standard on Denali)	0	0	0
Transfer case (4x4 models) – lever operated, 2-speed manual	S	S	–
Transfer case (4x4 models) – Autotrac with electronic push-button controls (standard on Hybrid and SLE Crew Cab, except Crew Cab Classic and Denali)	–	0	S
Transmission – 5-speed manual with overdrive (SL Reg. Cab with Vortec 4.3L V6 only)	S	–	–
Transmission – 4-speed automatic with overdrive and Tow/Haul mode	S <sup>1</sup>	S	S

<sup>1</sup>Optional on SL Reg. Cab.

## EXTERIOR

Box extender <sup>2</sup>	0	0	0
Box side rail protector <sup>2</sup>	0	0	0
Box – Fleetside Short (5 ft. 8 in.) – 1500 Ext. and Crew Cab	S	S	S
Box – Fleetside Standard (6 ft. 6 in.) – 1500HD Crew Cab	–	S	S
Box – Fleetside Standard (6 ft. 6 in.) or Long (8.0 ft.) – 1500 Reg. and Ext. Cab	S	S	S
Bumpers – front, chrome with spectra gray cover and air dam (colour-keyed lower cover on SLE and SLT)	S	S	S
Bumpers – rear chrome with step pad	S	S	S
Fender flares – wheel opening on 4x4s (standard on 1500HD models)	0	0	0
Fog lights	–	0	S
Glass – Solar-Ray tinted, all windows	S	S	S
Glass – deep-tinted on all windows behind front doors	0	0	S
Grille – moulded plastic, painted argent with chrome surround	0	S	S
Mirrors – foldaway, black	S	S	S
Mirrors – power remote control, heated	–	S	–
Mirrors – power remote control, heated, power folding with reverse down, electrochromic auto-dimming driver's side and integral turn signals	–	0	S
Mirrors – deluxe wide-load, vertical glass with lower convex spotter glass, heated with integrated turn signal, manual extending and folding	–	0	0
Mirrors – camper-style, manual extending	0	–	–
Mouldings – bodyside, black	0	–	–
Mouldings – bodyside, chrome	–	S	S
Pickup box tonneau cover – soft or hard cover design <sup>2</sup>	0	0	0
Recovery hooks – two front	S	S	S
Running boards – black, contoured (NA with Crew Cab) <sup>2</sup>	0	0	0
Side assist steps – tubular design, black or chrome finish <sup>2</sup>	0	0	0
Skid plates – off-road, included with 1500 Z71 suspension (4x4 only)	0	0	0
Snow Plow Prep Package – includes wiring for roof-mounted light, heavy-duty front springs, high-capacity air cleaner and 160 amp alternator (Reg. Cab 4x4 only) <sup>1</sup>	0	0	–
Sunroof – power, with express-open (Ext. Cab standard and long box and Crew Cabs)	–	0	0
Tires – 17" wheels with tire sizes ranging from P245/70R17 up to P265/70R17 all-season (except Denali, 1500HD and Hybrid models)	S	S	S
Tires – 16" wheels with LT245/75R16 all-season on 1500HD models	–	S	S

EXTERIOR (continued)	SL	SLE	SLT
Tires – 16" wheels with P235/75R16 (2WD), P245/75R16 (4x4) on Hybrid models	–	S	S
Tires – 20" chromed aluminum wheels with P275/55R20 all-season (1500 Ext. Cab and Crew Cab models)	–	0	0
Wheel trim – please refer to page 19 for description and availability	S	S	S

<sup>2</sup>Dealer-installed accessory. <sup>1</sup>Requires available V8 engine. Includes extra capacity transmission oil cooler.

## INTERIOR

Air conditioning – dual-zone, manual climate control (excludes Reg. Cab)	S	S	–
Air conditioning – dual-zone, automatic climate control	–	0	S
Console – mini overhead	–	S	S
Cruise control – electronic with resume, coast and decelerate/accelerate features	0	S	S
Cupholders – dual	S	S	S
Defogger – electric, rear-window (except Crew Cab Classic)	0	S	S
Floor covering – colour-keyed carpeting and removable vinyl floor mats (includes rear in Ext. and Crew Cabs)	0	S	S
Instrumentation – analogue, including speedometer, tachometer, voltmeter, coolant temperature, oil pressure, fuel gauge, odometer, trip odometer and engine hour meter	S	S	S
Instrumentation – Driver Information Centre, comprehensive multi-language system that displays numerous vehicle functions with both visual and audible reminders/warnings	S	S	S
Mirror – rear-view, electrochromic auto-dimming with compass and exterior temperature readouts (except Crew Cab Classic)	–	S	S
Personalization features – programs many comfort and convenience features using the steering wheel controls, including automatic locking/unlocking, seat position recall, perimeter lighting, exit lighting, remote lock/unlock feedback and reverse-down of exterior mirrors	–	–	S
Power outlet – one auxiliary, 12-volt, in addition to cigarette lighter receptacle	S	S	S
Smoker's Package – includes lighter and ashtray (standard with bench seating)	S	0	0
Steering column – tilt adjustable	S	S	S
Steering wheel – leather-wrapped (except Crew Cab Classic)	–	S	S
Stowage box – under rear seat (Ext. Cab standard and long box only)	0	0	0
Sunshades – LH and RH padded colour-keyed cloth; LH with pocket, RH with visor mirror	S	S	S
Windows – power, driver's express-down and passenger lock-out feature	–	S	S
Window – rear, manual sliding	0	0	0

## SEATS

Front 40/20/40 split-bench with manual driver's side recliner, vinyl or cloth trim	S	–	–
Front, Custom cloth 40/20/40 split-bench with manual recliners and centre armrest/storage – Ext. and Crew Cab also include seatback storage pockets	0	S	–
Front, 40/20/40 split-bench with leather seat inserts and driver's side 6-way power seat adjuster (NA on Reg. Cab) <sup>1</sup>	–	0	–
Front bucket seats with manual recliners, power 6-way driver seat adjuster, driver and front-passenger inboard armrests – includes seatback storage pockets and centre floor console – Custom cloth or leather seat inserts (except Reg. Cab) <sup>1</sup>	–	0	–
Full-feature front bucket seats with heated leather seat inserts, driver's side 2-position memory controls and power 10-way driver and front-passenger seat adjusters, including power lumbar supports and seatback recliners – includes driver and front-passenger inboard armrests, seatback storage pockets and floor console	–	–	S
Leather front seat inserts – Ext. and Crew Cab <sup>1</sup>	–	0	S
Head restraints, adjustable on all outboard seats	S	S	S
Power 6-way driver seat adjuster on 40/20/40 split-bench seat	–	0	–
Rear fold-up seat on Ext. Cab <sup>1</sup>	S	S	S
Rear 60/40 split fold-down seat on Crew Cab	–	S	S

<sup>1</sup>Rear seats are vinyl on SLE and SLT Ext. Cab models when leather seat inserts are specified.

## ENTERTAINMENT SYSTEMS

AM/FM stereo with seek/scan, digital clock and 4 speakers	S	–	–
AM/FM stereo with seek/scan, CD player, Radio Data System (RDS), auto tone control, digital clock and 6 speakers (4 speakers on Reg. Cab)	0	S	–
Same as above with both cassette tape and CD players	–	0	0
AM/FM stereo with seek/scan, 6-disc CD changer, Radio Data System (RDS), auto tone control, digital clock and 6 Bose premium speakers	–	0	S
XM Satellite Radio <sup>3</sup>	–	0	0
Bose premium speakers, included with bucket seats	–	0	S
Steering wheel audio controls	–	0	S
Rear-seat audio controls (Crew Cab)	–	0	S
DVD Entertainment Package – includes rear-seat overhead fold-down 178 mm (7 in.) LCD colour monitor, DVD player, video game input (RCA) jacks, rear-seat audio controls and wireless headphones (Crew Cab with bucket seats)	–	0	0

<sup>3</sup>Includes three trial months beyond which service fees apply. Available in 10 Canadian provinces and 48 contiguous United States. S – Standard. 0 – Optional individually or in combination with other optional equipment.

NOTE: The trim features indicated reflect only a portion of the content of the Sierra 1500 models. For a complete list, details and information on other Sierra models, please see your Sales Consultant for complete listings, current availability and compatibility.

## SUSPENSION PACKAGES

A variety of suspension packages is available on Sierras, providing ride characteristics tailored to your particular needs.

### 1500 MODELS

- **Standard Suspension (Z83)** – 35 mm twin-tube shock absorbers on 2WD models except SLT Extended Cabs.
- **Heavy-Duty Suspension (Z85)** – Standard on all 4x4s and SLT Extended Cabs with monotube 36 mm shocks for increased damping to improve handling and trailering.
- **Ride Control (ZK3)** – Optional on SLE and SLT 2WD and 4x4s. Manually adjusts the amount of shock absorber damping using a two-position switch for smooth road or increased control and trailering.
- **Off-Road (Z71)** – Includes 46 mm shock absorbers, special pounce bumpers and stabilizer bars, skid plates, high-capacity air cleaner and Z71 decals. Available on SLE and SLT 4x4s only.

### 1500HD, 2500HD AND 3500 MODELS

- **Heavy-Duty Suspension (Z85)** – Provides good carrying and trailering capabilities. Standard on these models.

## SIERRA 1500 PREFERRED EQUIPMENT GROUPS (PEGS)

- The first upgrade (1SB) adds the following features to the SL Ext. Cab models:
  - Carpeted floor covering and vinyl floor mats – Grille with chrome surround – Black bodyside mouldings
  - Rear locking differential (4x4 models) – Chrome-appearance wheels with chrome centre caps
- You can further upgrade the SL Reg. and Ext. Cab models by adding these convenience features (1SC) to the above:
  - Cruise control – Power programmable door locks – CD player
- You can also upgrade the SLE models to include these features (1SE):
  - Fog lights – Deep-tinted glass on all windows behind front doors – Autotrac 4x4 system (on 4x4 models, standard on Crew Cab except Classic) – 17" aluminum wheels

## VALUE LEADER REGULAR CAB

A value-based Regular Cab with limited option availability. Please see your Sales Consultant for complete details.

### Mechanical

- Engine: 195 hp Vortec 4.3L V6 – Transmission: 5-speed manual with overdrive
- Suspension: Standard (Z83) with 2WD/Heavy-Duty (Z85) with 4x4

### Exterior

- Grille: moulded plastic, painted argent – Wheels: 17" styled with painted centre cap

### Interior

- Seats: 40/20/40 split-bench, vinyl or cloth trim – Floor covering: black vinyl

## SIERRA DENALI CREW CAB

Below are some of the standard features that make the 1500 Sierra Denali Crew Cab such an outstanding vehicle.

### Mechanical

- Engine: 345 hp VortecMAX 6.0L V8 – Transmission: Heavy-duty 4-speed automatic (4L65E) – Drivetrain: Full-time all-wheel drive (AWD) – Locking rear differential – Trailering Special Equipment Package

### Exterior

- Bumpers: Colour-keyed front and rear – Exhaust tip: Chrome-plated – Grille: Special chrome design
- Mirrors: Heated and power adjustable, with colour accents, power folding with curb-view assist, integral turn signal indicators and side entry illumination, driver's side electrochromic auto-dimming – Mouldings: Deluxe bodyside – Side steps: Full-length tubular, chrome – Tires: P275/55R20 all-season blackwell
- Wheels: Specific 20" aluminum

### Interior

- Air conditioning: Dual-zone automatic climate control – Driver Information Centre – Carpeting: Front and rear with carpeted floor mats – Personalization feature – Rear-seat audio controls and headphone jacks – Sound system: AM/FM stereo with seek/scan, cassette tape player, 6-disc in-dash CD changer, auto tone control, AudioPilot noise-compensated volume control, digital clock and 6 premium Bose speakers – Steering wheel sound system controls – Seats: Full-feature reclining front buckets with heated leather seat inserts and 10-way power seat adjusters including power lumbar supports and side bolsters – Sunshades: Illuminated visor mirrors – Universal home remote: 3-channel transmitter

## SPECIAL PACKAGES

### SIERRA CLASSIC

A value-based Crew Cab with limited option availability

#### SLE Crew Cab 1500 2WD and 4x4 models

- 285 hp Vortec 4.8L V8 – 4-speed automatic transmission – Heavy-duty suspension – Tires: P245/70R17 all-season on 2WD models, P265/70R17 all-season on 4x4 models – Air conditioning, dual-zone manual control – AM/FM stereo with CD player

### FAMILY CAB PACKAGE

#### SLE, SLT and Denali Crew Cab 1500 models

- Entertainment Package includes DVD player and wireless headphones – XM Satellite Radio – Power sunroof

### SIERRA NEVADA EDITION PACKAGES

#### SL Regular or Extended Cab 1500 2WD and 4x4 models

- Custom cloth seat trim – Heavy-duty suspension (standard on 4x4s) – 17" aluminum wheels
- Deep-tinted glass on all windows behind front doors – Locking rear differential (standard on 4x4s)
- Chromed stainless steel tubular side steps – Sierra Nevada Edition decals

#### SLE Regular, Extended and Crew Cab 1500 2WD and 4x4 models

- Heavy-duty suspension (standard on 4x4 and Crew Cab models) – 17" aluminum wheels – Deep-tinted glass on all windows behind front doors – Fog lights – Locking rear differential (standard on 4x4s) – Chromed stainless steel tubular side steps – Sierra Nevada Edition decals

### VORTECMAX PERFORMANCE PACKAGE

#### SLE, SLT Extended Cab with standard box and Crew Cab 1500 2WD and 4x4 models

- Heavy-duty rear axle with a 9.5 in. diameter ring gear – Engine oil cooler – P265/70R17 On/Off-Road tires
- 345 hp VortecMAX 6.0L V8 engine – 4-speed super-duty automatic transmission (4L70E) – Adjustable Ride Control Suspension – Autotrac transfer case (standard on Crew Cab and 4x4 models) – Trailering Special Equipment Package – "VortecMAX" door badge and engine cover decal

## SPECIAL PACKAGES (continued)

### 20" CHROME WHEEL PACKAGE

- **SLE, SLT Extended Cab short and standard box models and SLE, SLT Crew Cab models (except Classic)**
  - 20" x 8.5" 5-spoke, chromed aluminum wheels (4) – High-performance suspension (2WD models)
  - P275/55R20 all-season performance tires (4) – Rear axle ratio: 3.73:1

### SLE Crew Cab Classic

- 20" x 8.5" 5-spoke, chromed aluminum wheels (4) – P275/55R20 all-season performance tires (4)

### SIERRA PERFORMANCE EDITION

#### SLE, SLT Extended Cab 1500 with standard box 2WD models

- 345 hp VortecMAX 6.0L V8 engine – 4-speed heavy-duty automatic transmission (4L65E) – Auxiliary transmission oil cooler – High-performance suspension – 20" x 8.5" 5-spoke, chromed aluminum wheels (4) – P275/55R20 all-season tires – "VortecMAX" door badge and engine cover decal

### VORTEC 5.3L V8 HAULER PACKAGES

#### SLE Regular and SLE, SLT Extended Cab 1500 2WD models with Fleetside standard or long box:

- 295 hp Vortec 5.3L V8\* – Trailering Special Equipment Package – Locking rear differential
- ZK3 Adjustable Ride Control suspension

#### SLE, SLT Crew Cab 1500 2WD models with Fleetside short box:

- Trailering Special Equipment Package – Locking rear differential

### VORTEC 5.3L V8 OFF-ROAD PACKAGES

#### SLE Regular and SLE, SLT Extended Cab 1500 4x4 models with Fleetside short, standard or long box:

- 295 hp Vortec 5.3L V8\* – Trailering Special Equipment Package – Z71 Off-Road Suspension Package
- P265/70R17 On/Off Road tires – Autotrac 4x4 transfer case (standard on SLT and up-level SLE Extended Cab models)

#### SLE, SLT Crew Cab 1500 4x4 models with Fleetside short box:

- Trailering Special Equipment Package – Z71 Off-Road Suspension Package

\*Standard on SLE Extended Cab long box and SLT models. Extended Cab 4x4 standard box models feature the aluminum block High-Output Vortec 5.3L V8 with 310 hp.

# DIMENSIONS

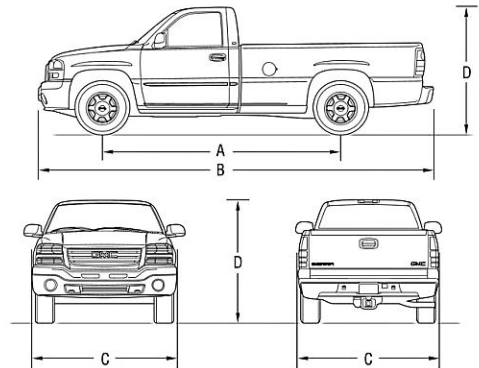

MODEL	A. Wheelbase mm (in.)	B. Overall Length mm (in.)	C. Width mm (in.)	D. Height mm (in.)
Regular Cab standard box	3023 (119.0)	5225 (205.7)	2024 (79.7) (max.) <sup>1</sup>	1808 (71.2) (max.) <sup>1</sup>
Regular Cab long box	3378 (133.0)	5702 (224.5)	2441 (96.1) (max.) <sup>1</sup>	1963 (77.3) (max.) <sup>1</sup>
Extended Cab short box	3404 (134.0)	5593 (220.2)		
Extended Cab standard box	3645 (143.5)	5847 (230.2)		
Extended Cab long box	4001 (157.5)	6325 (249.0)		
Crew Cab short box (1500)	3645 (143.5)	5847 (230.2)		
Crew Cab standard box (1500HD)	3886 (153.0)	6027 (237.3)		
Crew Cab long box (2500HD, 3500)	4242 (167.0)	6507 (256.2)		

<sup>1</sup>Excluding mirrors. <sup>2</sup>Depending on model selected.

# COLOURS. FABRICS. WHEELS.

## Exterior Colours



15 - Sand Beige Metallic<sup>††</sup>



16 - Steel Gray Metallic



25 - Deep Blue Metallic



41 - Onyx Black\*\*



46 - Stealth Gray Metallic



47 - Polo Green Metallic\*†



50 - Summit White\*\*



59 - Silver Birch Metallic\*\*



63 - Sport Red Metallic††



74 - Fire Red

Due to limitations in the printing process, the colours shown may differ slightly from the actual colour. Please see your Sales Consultant for specific colour and model availability and compatibility.

## THE GM WARRANTY:<sup>†</sup>

The New Vehicle Limited Warranty is your promise of total warranty protection. It applies to the first owner and all future owners of the vehicle, and covers repairs to correct vehicle defects related to materials or workmanship during the warranty period. The warranty includes:

- 3-year/60,000 km\* Base warranty coverage
- 6-year/160,000 km\* rust-through perforation coverage
- 8-year/130,000 km\* coverage on catalytic converters and powertrain control modules (PCMs)
- 5-year/160,000 km\* Duramax Diesel warranty coverage<sup>†</sup>
- 8-year/160,000 km\* Hybrid Component warranty coverage.<sup>†</sup>

\*Whichever comes first. †Conditions and limitations apply.

## OTHER OWNERSHIP PRIVILEGES AND PROGRAMS:<sup>†</sup>

- **Roadside Assistance** – 24/7 service via toll-free number during the Base warranty period, anywhere in Canada or the United States
- **Courtesy Transportation** – may be offered during the Base warranty period
- **GM Protection Plan (GMPP)** – the only extended service contract backed by the resources and commitment of General Motors; GMPP may be purchased at the time of your sale or lease, or subsequently during the Base warranty period.
- **GM Goodwrench Service** – with GM-certified technicians and GM-approved parts, nobody knows your GM vehicle better.

<sup>†</sup>Conditions and limitations apply.

## TO HELP YOU PURCHASE OR LEASE A NEW VEHICLE:

- **GMAC Financing** – on-the-spot financing at your GM dealership<sup>††</sup>
- **GMAC SMARTLEASE** – a smart alternative to traditional financing<sup>††</sup>
- **GM Student Bonus Program** – GM will cover the first two purchase finance or lease payments and the lease security deposit on eligible new GM vehicles for students and recent graduates of high school, college or university<sup>†</sup>
- **The GM Card** – eligible cardholders may be able to redeem up to \$3500 in GM Card<sup>®</sup> Earnings toward the total purchase price or lease down payment on selected vehicles! For more information on The GM Card please call 1-800-461-3279.

<sup>†</sup>Conditions and limitations apply. <sup>††</sup>Subject to eligibility.

## INFORMATION RESOURCES:

You can find more information about these programs from your GM dealer, or at these information centres:

- The GM Website at [gmcanada.com](http://gmcanada.com)
- The GM Customer Communication Marketing Centre at 1-800-GM-DRIVE (1-800-463-7483 or 1-800-263-3830 for TDD users)
- For information about GMAC visit [gmcanada.com](http://gmcanada.com) or call 1-800-616-4622



## Exterior/Interior Colour Compatibility

Exterior	Interior		
	52 – Neutral	69 – Dark Pewter	92 – Pewter (leather only)
15 – Sand Beige Metallic**	X	X	X
16 – Steel Gray Metallic	X	X	X
25 – Deep Blue Metallic	X	X	X
41 – Onyx Black**	X	X	X
46 – Stealth Gray Metallic	X	X	X
47 – Polo Green Metallic**	X	X	X
50 – Summit White**	X	X	X
59 – Silver Birch Metallic**	X	X	X
63 – Sport Red Metallic††	X	X	X
74 – Fire Red	X	X	X

\*Not available on 1500 Crew Cabs \*\*Available on Denali models.

†Not available on 1500 HD Crew Cabs. ††Not available on Base or Value Leader models.

Please see your Sales Consultant for specific two-tone colour and model availability.

## Interior Fabrics

**Vinyl standard** on SL.



52V – Neutral



69V – Dark Pewter

**Cloth** available on SL at no extra charge.



52C – Neutral

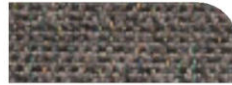

69C – Dark Pewter

**Custom cloth standard** on SLE.

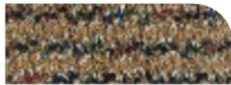

52D – Neutral



69D – Dark Pewter

**Leather seat inserts standard** on SLT. Available on SLE.



522 – Neutral



692 – Dark Pewter

**Nuance leather seat inserts standard** on Denali.



522 – Neutral



922 – Pewter

## Wheels

### 1500 Series



17" x 7.5" Styled Steel with cap, painted silver. Standard on Value Leader Regular Cab and SL Ext. Cab.



17" x 7.5" Chrome Styled Steel with chrome cap. Standard on SL Reg. Cab, SLE models and Crew Cab Classic models. Available on SL Ext. Cab. (PY9)



16" x 7" Bright aluminum. Standard on Sierra Hybrid. (PF4)



17" x 7.5" 6-Spoke aluminum. Available on SLE and standard on SLT. (0F7)



17" x 7.5" Deluxe aluminum. Available on SLE and SLT. Included with VortecMAX Performance Package. (PZ7)



20" x 8.5" Chromed aluminum. Available with the 20" Chrome Wheel Package or Sierra Performance Edition.

### 1500HD/2500HD Series



16" x 6.5" Steel with cap, painted silver. Standard on 2500 HD SL.



16" x 6.5" Chromed Styled Steel with chrome cap. Standard on 1500HD and 2500HD SLE, available on 2500 HD SL. (PY2)



16" x 6.5" Polished Forged Aluminum. Standard on 1500HD and 2500HD SLT models. Available on 1500HD SLE and 2500HD SL and SLE. (PY0)

### Denali



20" x 8.5" Chromed aluminum. Standard on Denali.

### 3500 Series Single Rear Wheel



16" x 6.5" Steel with cap, painted silver. Standard on SL. Includes chrome centre cap on SLE and SLT. (P03)

### 3500 Series Dual Rear Wheel



16" x 6.5" Styled Steel with cap, painted silver. Standard on SL.



16" x 6.5" Styled Steel painted silver with chrome trim rings and cap. Standard on SLE and SLT. Available on SL. (P06)



922 – Pewter

## A WORD ABOUT THIS BROCHURE

Some of the equipment shown or described throughout this brochure may be available at extra cost. We have tried to make this brochure comprehensive and factual. We reserve the right, however, to make changes at any time, without notice, in prices, colours, materials, equipment, specifications, models and availability. Specifications, dimensions, measurements, ratings and other numbers in this brochure and other printed materials provided at the dealership or affixed to vehicles are approximates based upon design and engineering drawings and prototypes and laboratory tests. Your vehicle may differ due to variations in manufacture and equipment. Since some information may have been updated since the time of printing, please check with your GM dealer for complete details. General Motors of Canada Limited reserves the right to lengthen or shorten the model year for any product for any reason, or to start and end model years at different times.

## A WORD ABOUT ASSEMBLY

GM vehicles are equipped with engines and components produced and assembled by different operating units of General Motors, its subsidiaries and suppliers and these engines and components may change or be obtained from different sources from time to time. All such engines and components are approved for use in GM vehicles. Certain equipment ordered may be unavailable at the time of assembly and we suggest that you verify that your vehicle includes the equipment you ordered, or if there are changes, that they are acceptable to you.

## TRADEMARKS

The marks appearing in this brochure including, but not limited to: General Motors, GM, the GM Canada emblem, the GM Canada website address, the GM Accessories logo, GMC, the GMC logo, Buick, Cadillac, Chevrolet, Classic, Denali, GMC, HHR, HUMMER, Pontiac, Saab, Saturn, Sierra, Solstice and their respective logos, emblems, slogans and vehicle model names and body designs; and other marks such as Z71, Autotrac, Duramax, PASSLock, SMARTLEASE, Solar-Ray, VortecMAX and Vortec are all trademarks of General Motors Corporation and/or General Motors of Canada Limited, its subsidiaries, affiliates or licensors.

GMAC is a registered trademark of the General Motors Acceptance Corporation.

OnStar, the OnStar logo and the OnStar button are registered trademarks of the OnStar Corporation.

TheftLock is a registered trademark of Delphi Automotive Systems.

Bose and AudioPilot are registered trademarks of the Bose Corporation.

Radio Data System (RDS) is a registered trademark of the U.S. National Association of Broadcasters.

The XM name and related logos are registered trademarks of XM Satellite Radio Inc.

## COPYRIGHT

© Copyright 2006 General Motors of Canada Limited. All Rights Reserved. All text, images, graphics, and other materials in this brochure are subject to the copyright and other intellectual property rights of General Motors Corporation and/or General Motors of Canada Limited. These materials may not be reproduced, distributed or modified without the express written permission of General Motors Corporation and/or General Motors of Canada Limited.

Printed in Canada, June 2006.



# SOLUTIONS FOR THE WORLD YOU DRIVE IN.

**At General Motors we are 100 percent committed to building vehicles that answer your specific needs. Because you demand more of your vehicle than ever before, we're committed to putting more of what you want into every vehicle we make.**

## VALUE

Value means much more than simply the price you pay for a vehicle. We are particularly proud of the value you receive for your money when you choose a General Motors vehicle – the unique combination of style, performance, safety, quality and functionality that sets GM's diverse model lineup apart from the rest.

## QUALITY

If you're looking for a vehicle that's built to exceptionally high standards, look no further than GM's long list of quality and dependability awards, media accolades and consumer recommendations – as well as the fact that GM builds the most dependable, longest-lasting full-size pickups on the road.\*

## SAFETY

General Motors is the only automotive manufacturer committed to offering a full range of cars, trucks and SUVs that provide safety protection before, during and after a collision. In addition, GM builds 26 vehicles that have earned U.S. Government five-star frontal or side crash test ratings for 2006 models.\*\*

## FUEL ECONOMY

We know how important fuel efficiency is today. GM has it covered by offering more cars that get better than 7.0 L/100 km or 40 mpg in highway<sup>†</sup> driving than any other automaker in Canada. In addition, GM offers 15 models with Active Fuel Management™ fuel-saving technology – and 17 models that can run on E85 ethanol fuel.

## INNOVATIVE DESIGNS

It required ingenuity to bring utility and dramatic style together in the Chevrolet HHR. And it required pure creativity to execute the flawless lines and purposeful design of the Pontiac Solstice open-air roadster. At GM, we break the mould to develop new designs that give you more range of selection than ever before.

## FEATURES

GM keeps you ahead of the curve, by adding the features that really make a difference to your driving experience. Features like OnStar – the first comprehensive in-vehicle communications and assistance service. And XM Satellite Radio – the largest satellite radio provider in the world – that's now offered on more than 50 GM vehicles.

\*Dependability based on longevity; 1988-July 2005 full-size Chevrolet and GMC light-duty pickup registrations, including chassis cabs. Sources: R.L. Polk Canada, Inc. National Vehicle Population Profile – Canadian Vehicles in Operation as of July 1, 2005. Based on % of vehicles remaining in operation, weighted on age of vehicle.

\*\*U.S. Government ratings are part of the National Highway Traffic Safety Administration's (NHTSA's) New Car Assessment Program (safercar.gov).

†Based on Natural Resources Canada's 2006 Fuel Consumption Guide's rating available at time of printing.

™© 2005, VANOC. Used under License.

CHEVROLET PONTIAC BUICK GMC SATURN HUMMER SAAB CADILLAC

[gmcanada.com](http://gmcanada.com)

